

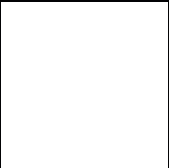

**BMW
MOTORRAD**



Booklet available in English on
Heft in deutscher Sprache erhältlich auf
Livret disponible en français sur
Libretto disponibile in italiano su
Folleto disponible en español en
如需中文版手册, 请访问







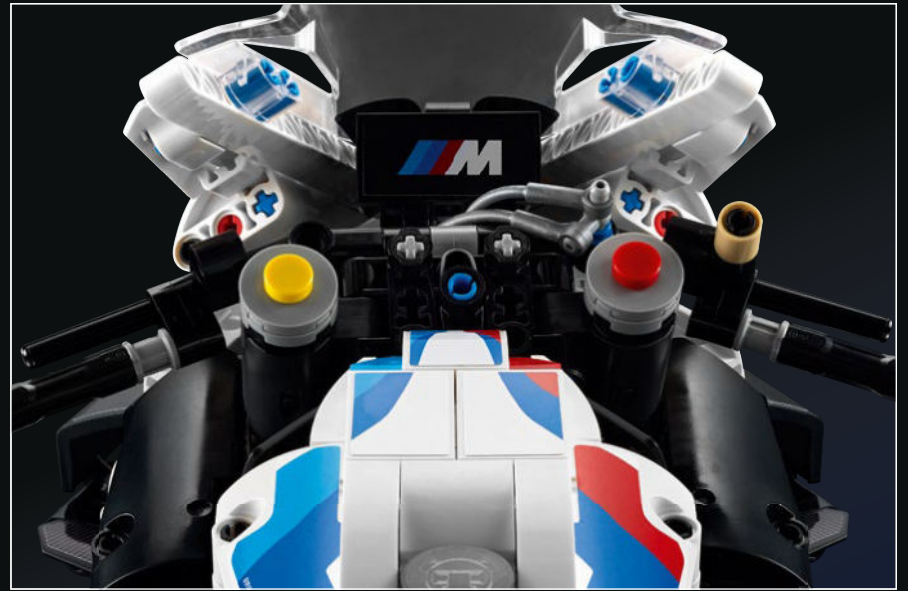
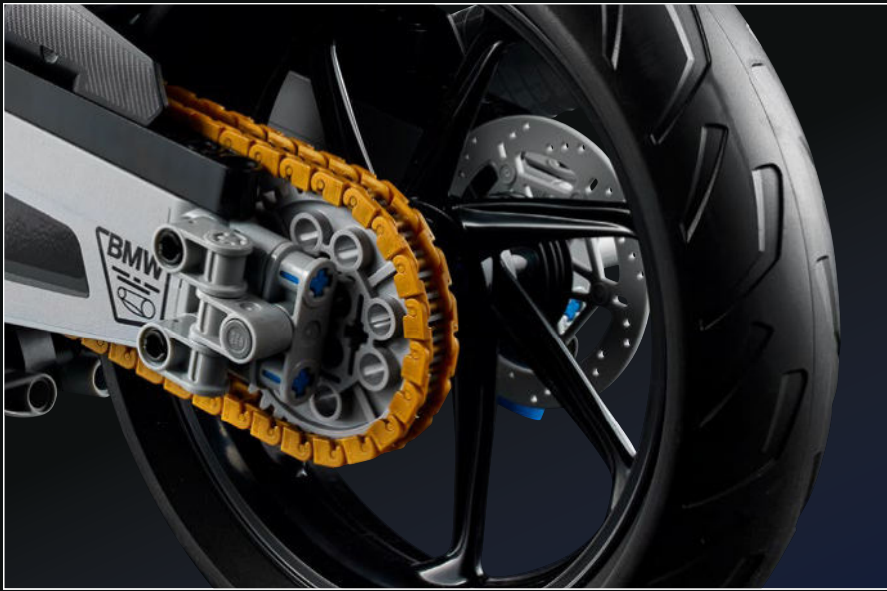

BMW M 1000 RR

When BMW Motorrad's in-house performance experts announced the first-ever M-developed motorcycle, the BMW M RR, everyone knew that the result was going to be something special. In the same way, the LEGO® Technic team realised it would take something never seen before to pay true tribute to the M RR. The result is both a motorcycle and a Technic model that are state-of-the-art within their respective fields.





THE PINNACLE OF PERFORMANCE

The quest for enhanced performance on both racetrack and road is what defines this M version of a high-performance motorcycle. With the original RR superbike as the perfect foundation, the BMW Motorrad team set about coaxing more power out of the water-cooled 999-cc inline four-cylinder engine, while also introducing design upgrades like carbon fibre wheels and titanium exhaust system to reduce overall weight.





A MATTER OF SCALE

The first challenge the LEGO® Technic designers faced was to set the scale of the model. Too small and it would be difficult to replicate the many features and functions of the real M RR. Too big and it would challenge the Technic building system. With a 1:5 scale, it became the largest Technic motorcycle model ever created. The Technic team worked closely with the designers and engineers at BMW Motorrad to ensure the LEGO Technic version was as close to the real M RR as possible.

SAMUEL TACCHI
Designer
LEGO® Technic





“

**IT TOOK ME BACK TO WHEN I WAS
DESIGNING MOTORCYCLES.”**

Samuel Tacchi



With a background in motorcycle design and a huge passion for riding them as well, LEGO® Technic designer Samuel Tacchi was the natural choice to lead this project.

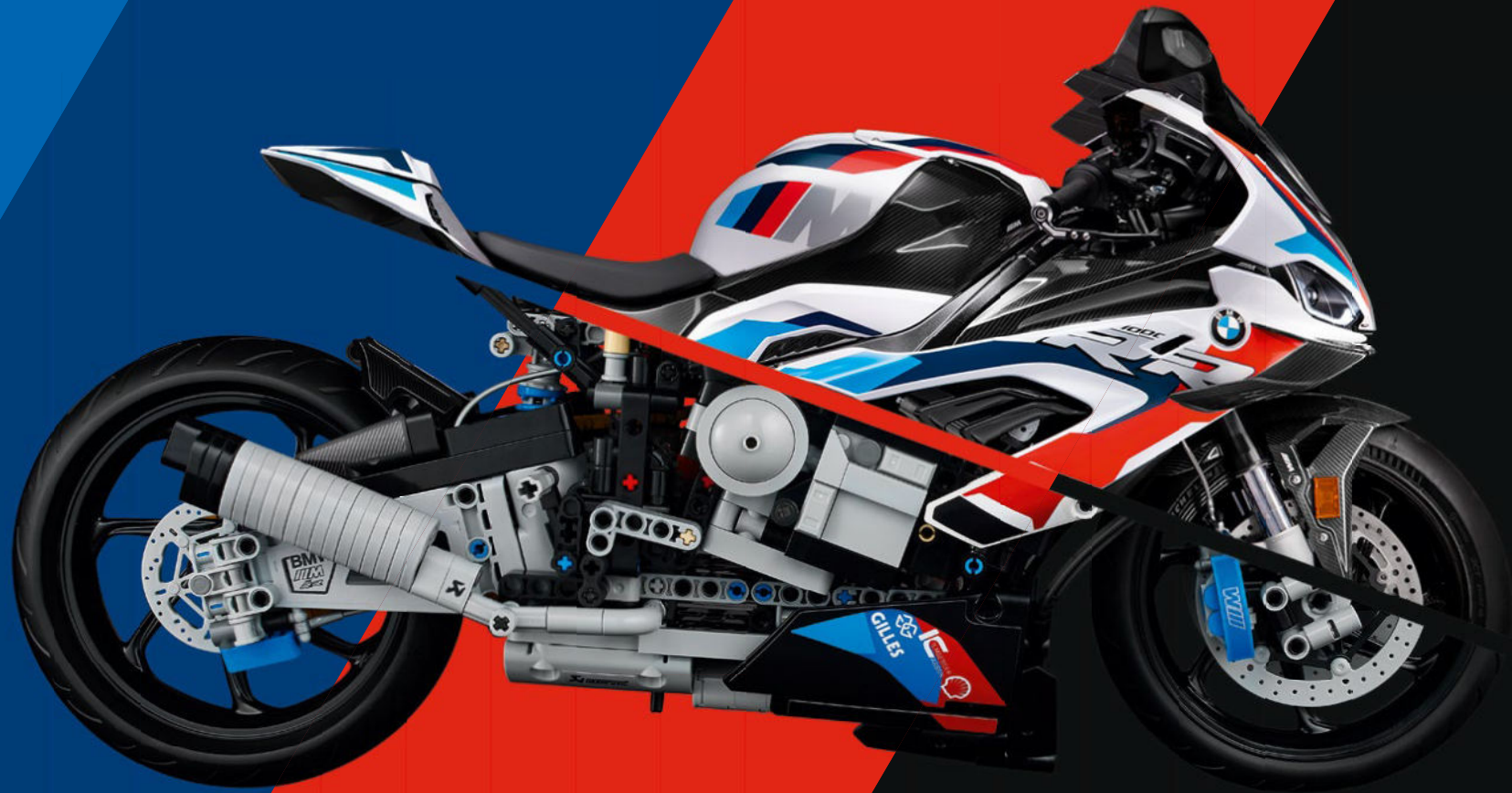



PUSHING THE TECHNIC BUILDING SYSTEM

The Technic version of the M RR needed the design of eight new pieces and Senior Designer Daniel Sri Sudarsono oversaw this process. It started with the new front and rear suspension setup needed to support the 1.4 kg (3 lbs.) weight of the model. New rims, disc brakes and a transparent windscreen quickly followed, all of which had to be tried and tested before being approved for use in the final model.

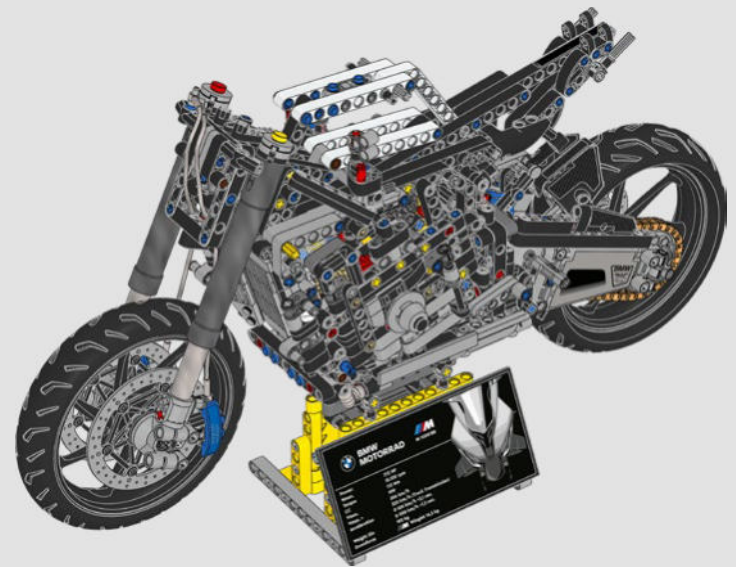
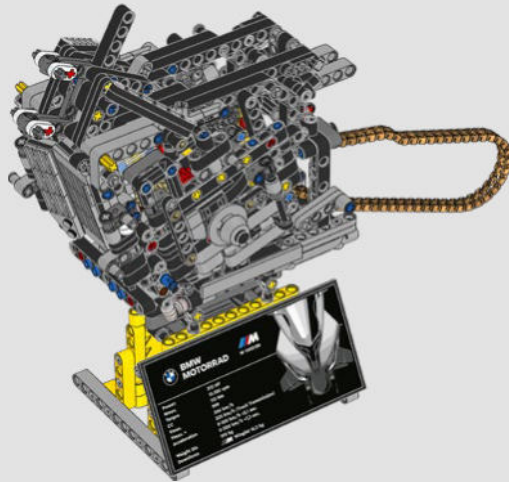
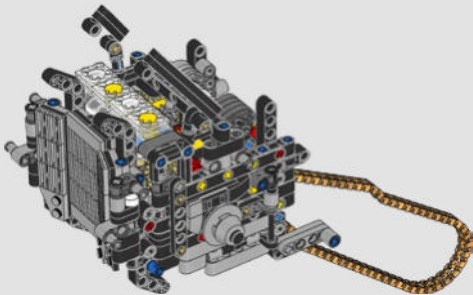
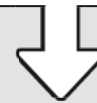
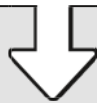
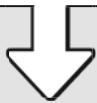

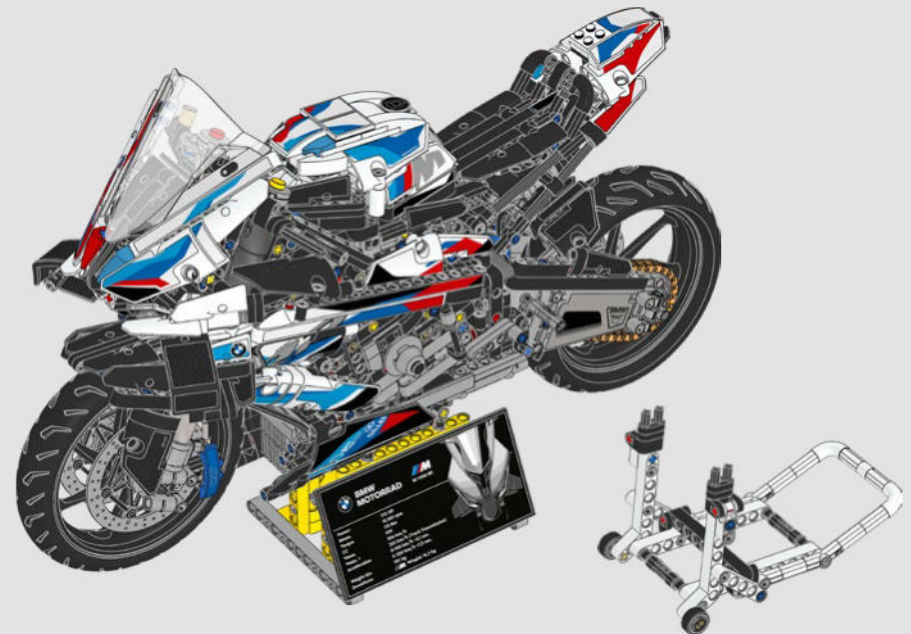
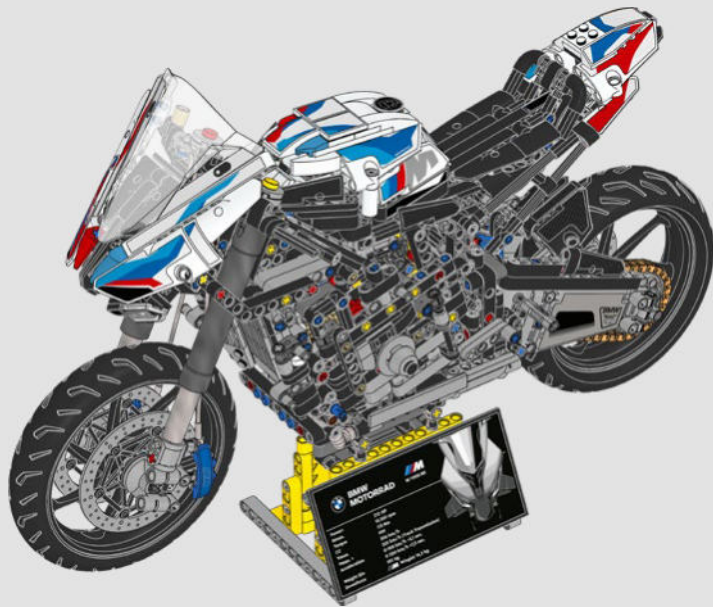

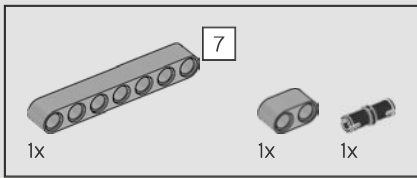
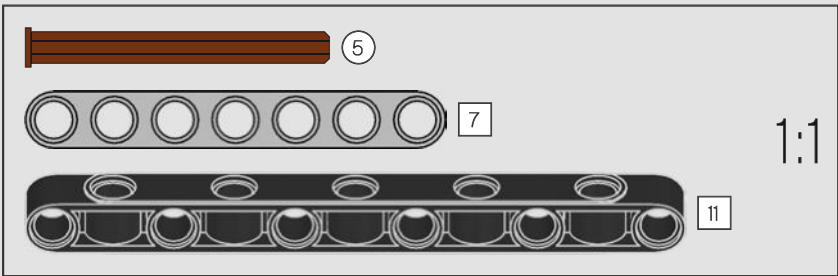
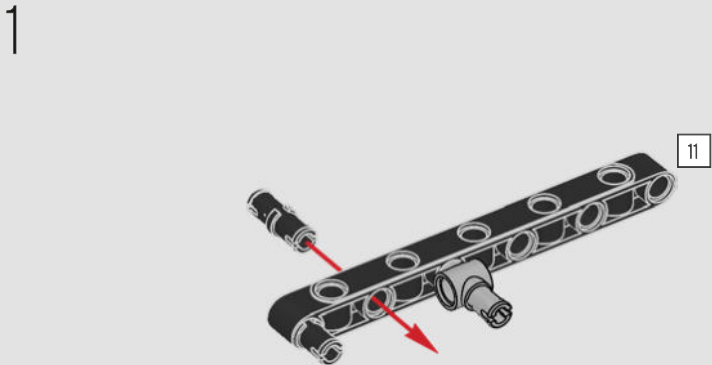
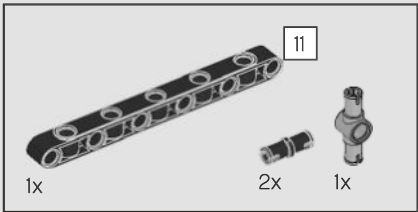
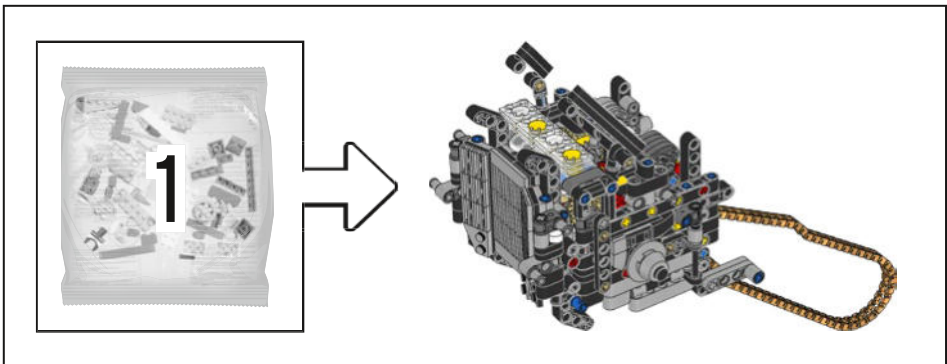

2

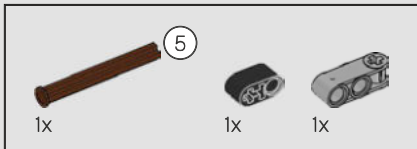
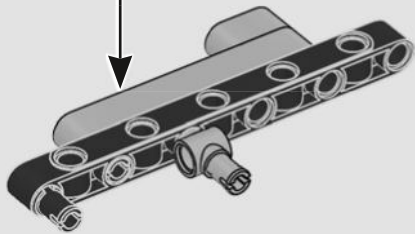
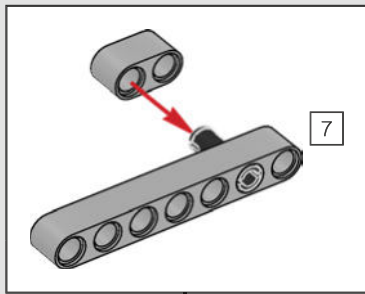

3

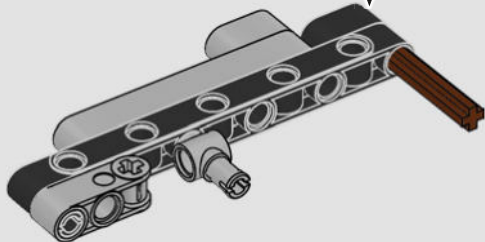
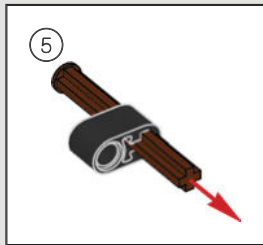



4

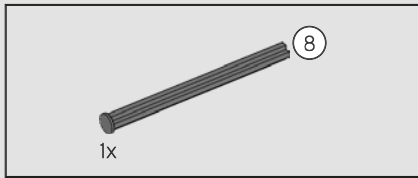
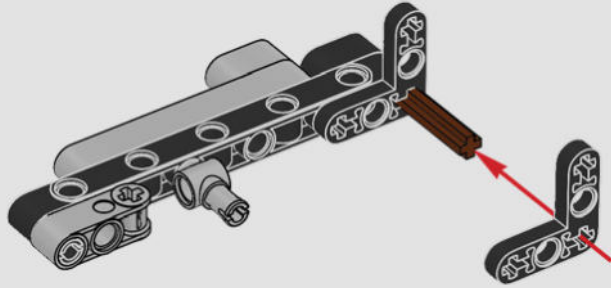

5

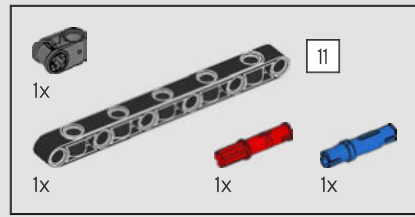
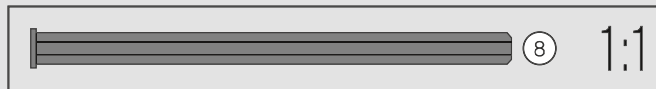
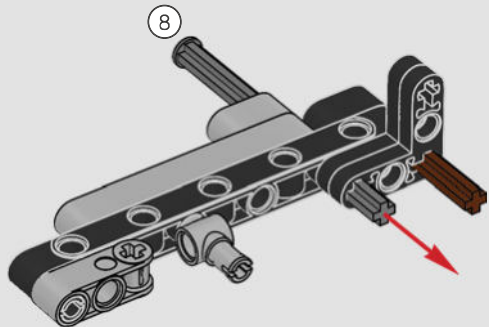

6

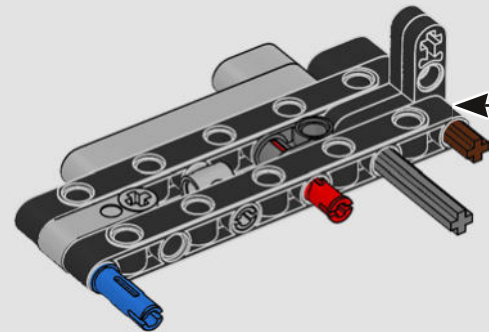
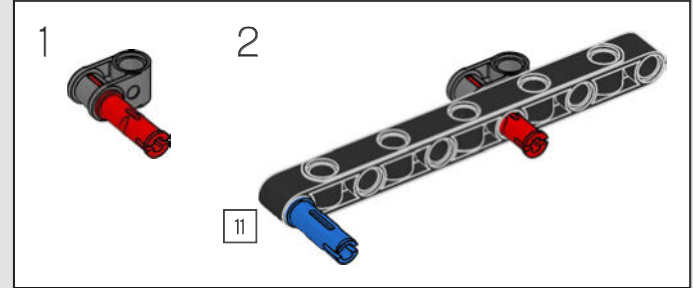

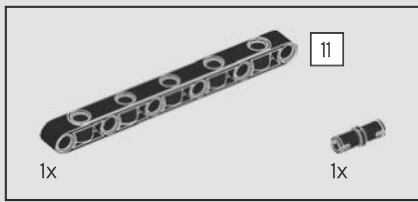

7

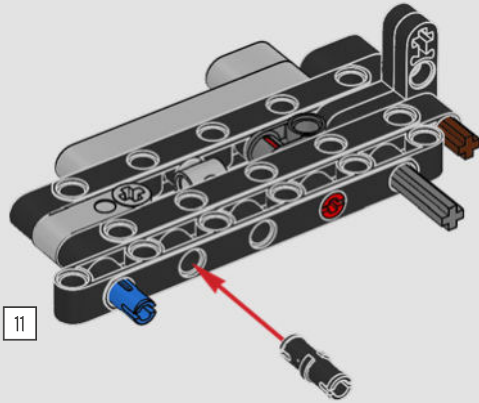

11

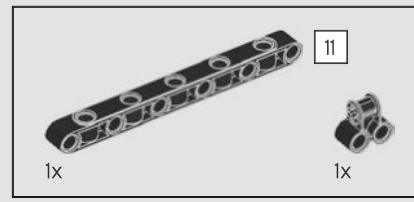
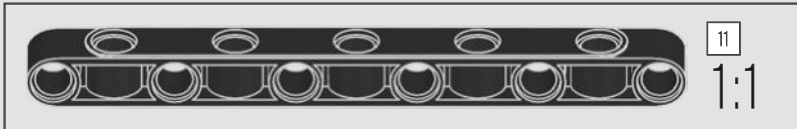

8

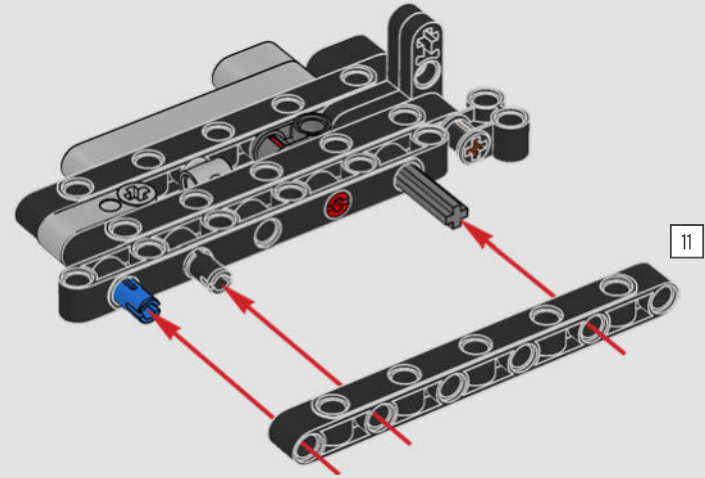

11

11

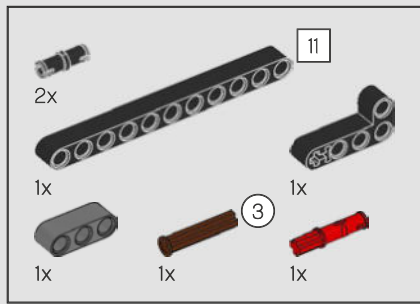

9

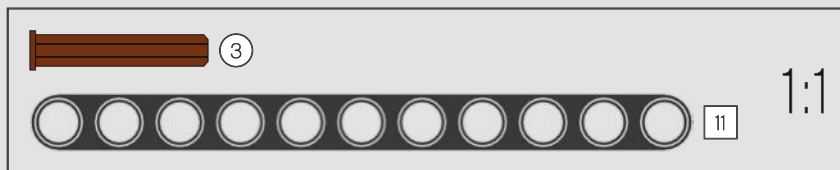
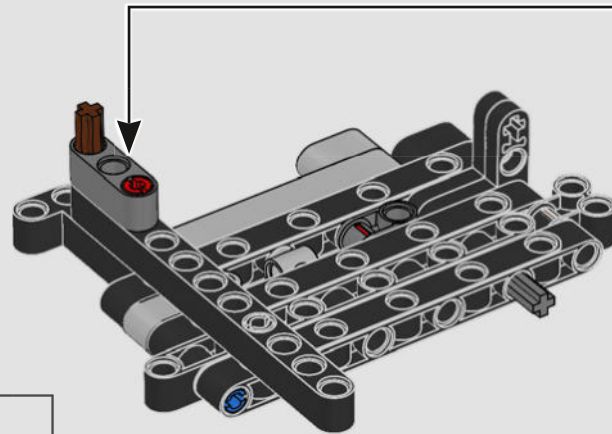
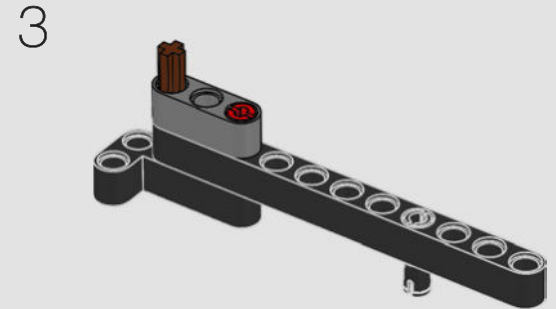
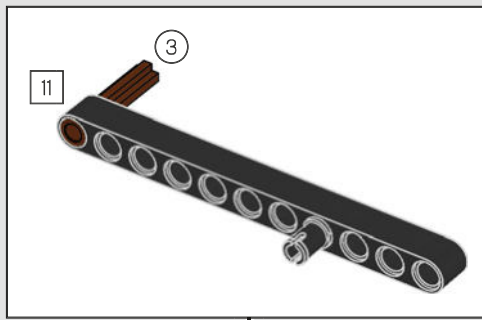
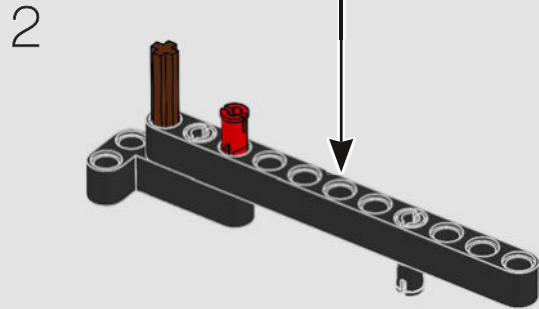
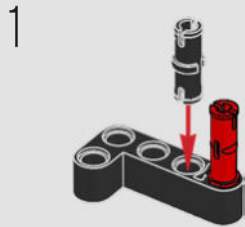

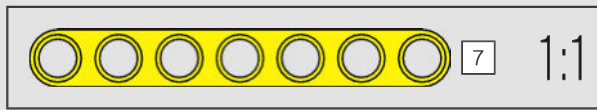
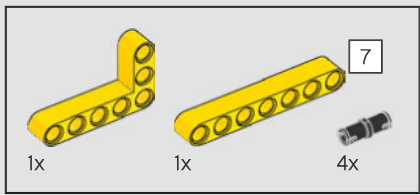

10

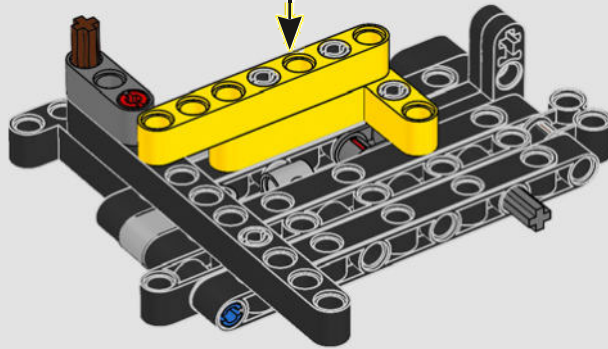
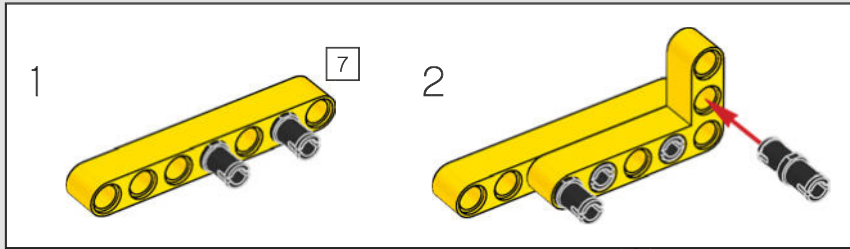

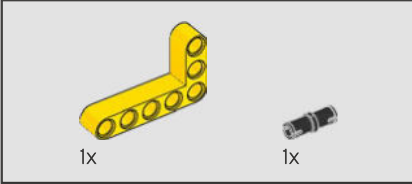
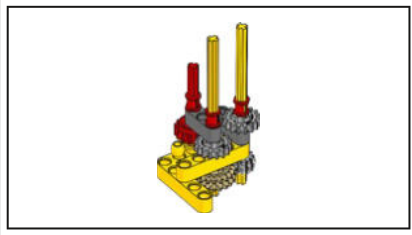

11

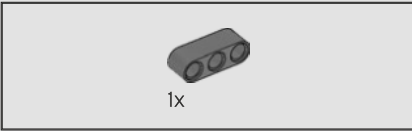
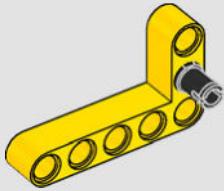

12

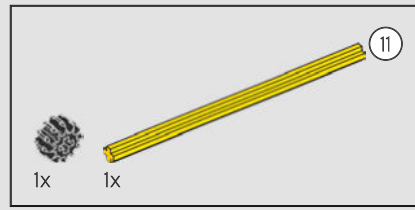
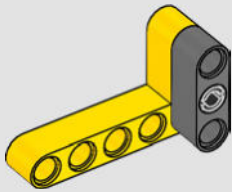

13

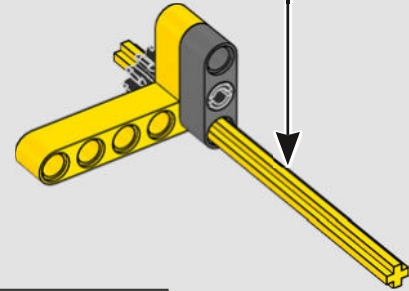
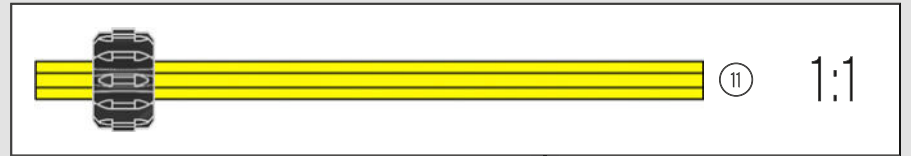

14

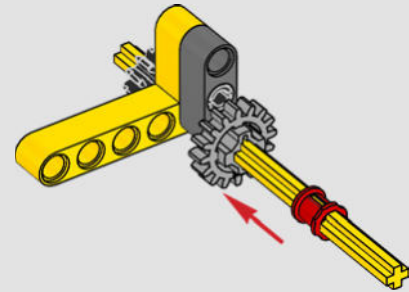

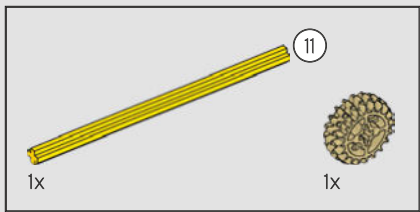

15

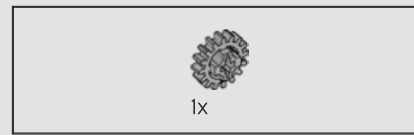
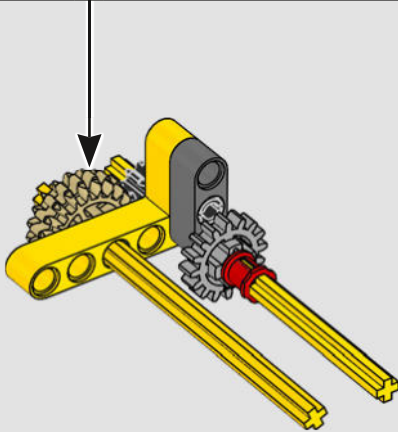
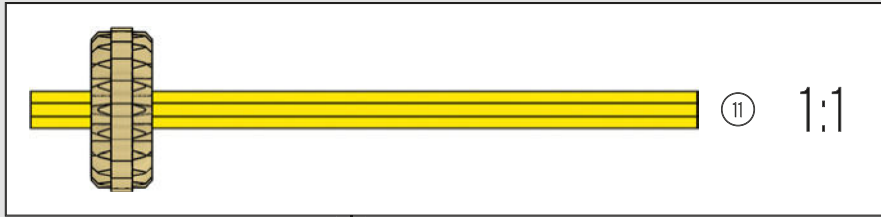

16

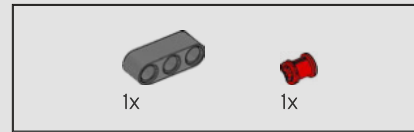
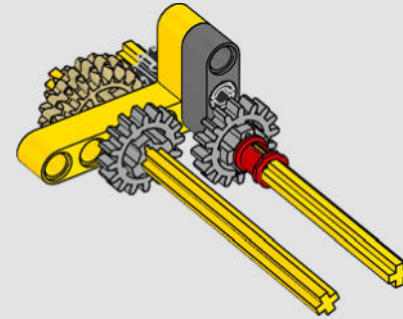

17

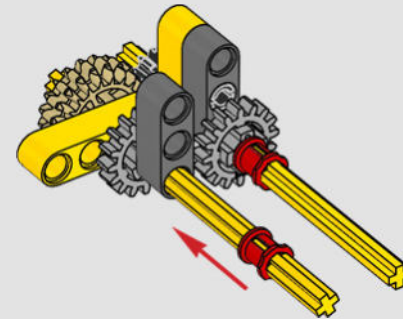

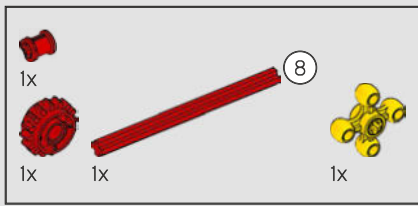

18

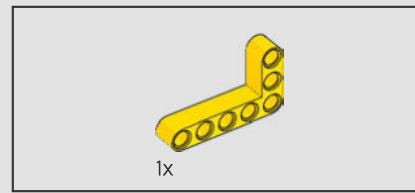
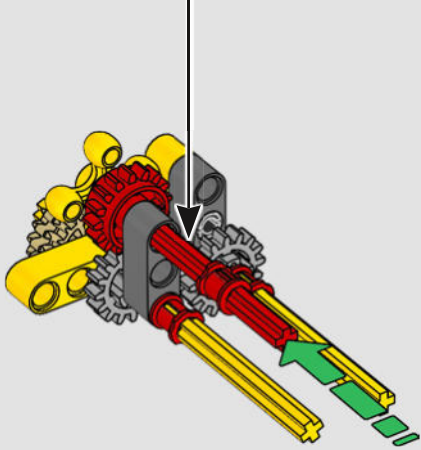
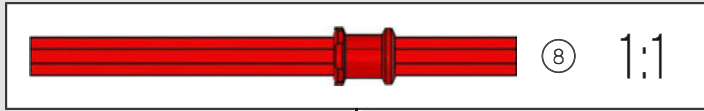

19

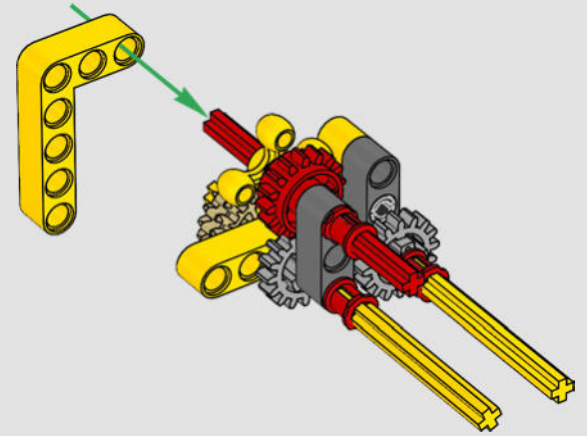

20

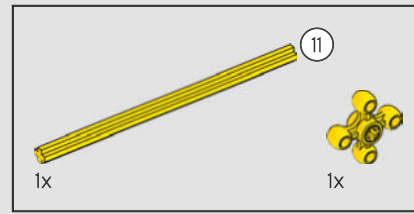
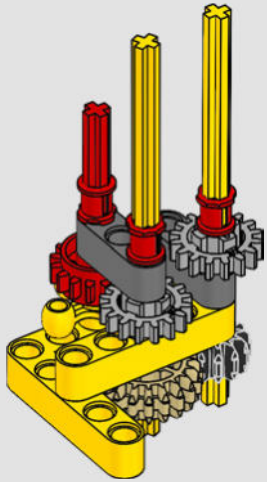

22

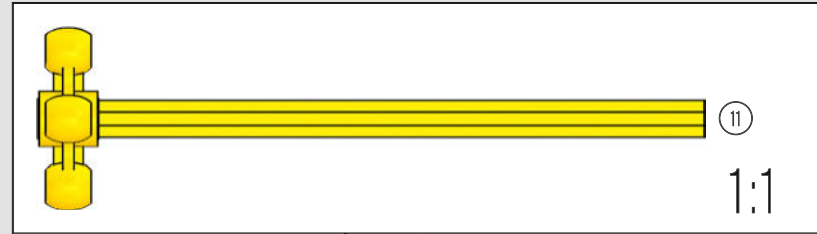

21

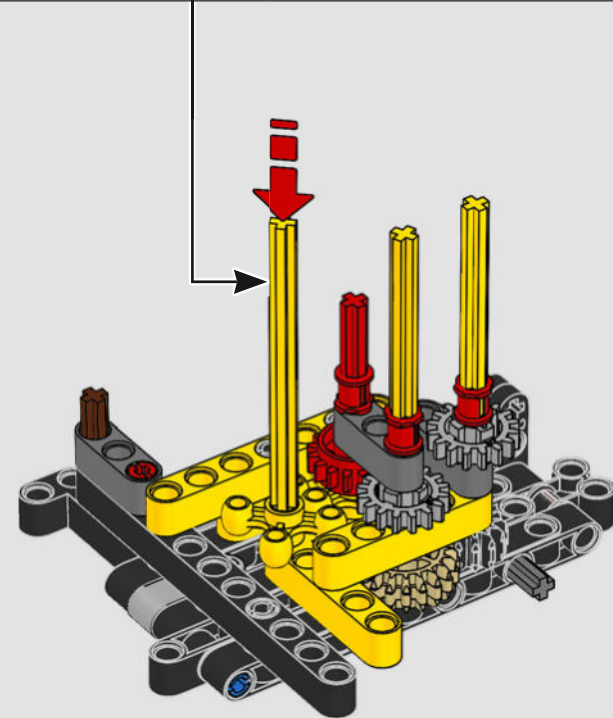
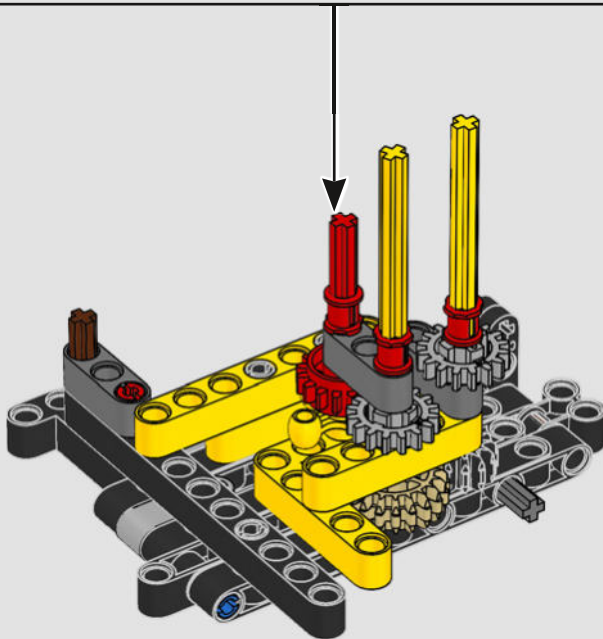

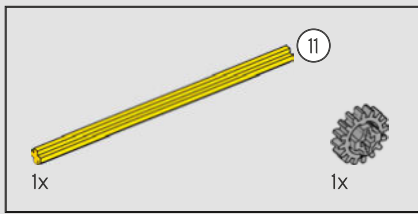

23

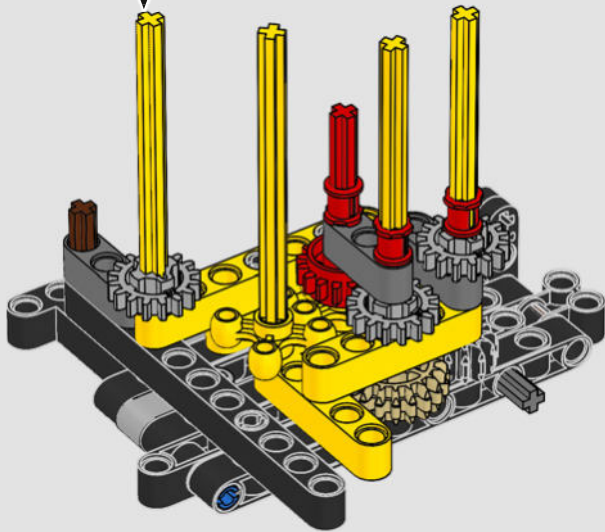
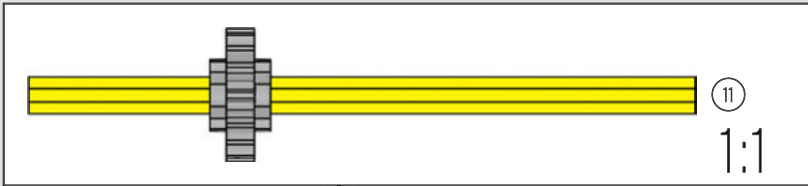

24

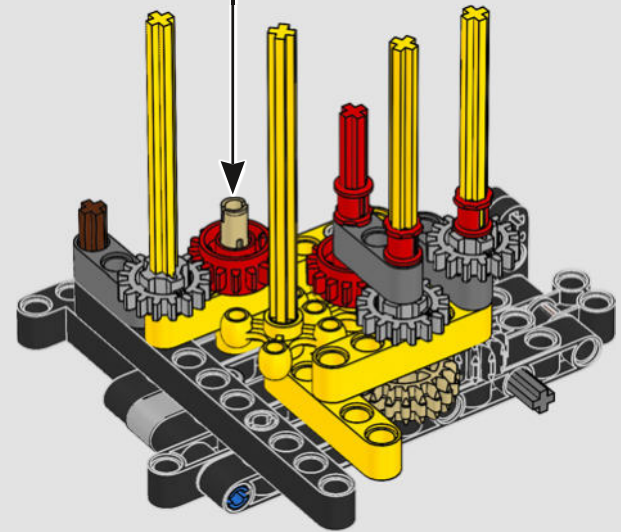
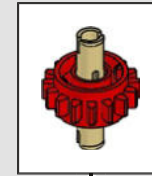

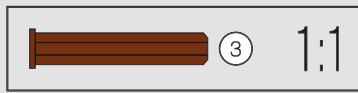
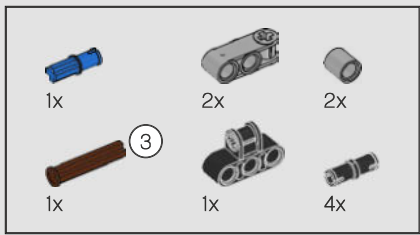

25

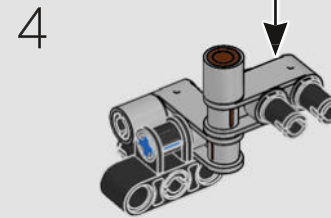
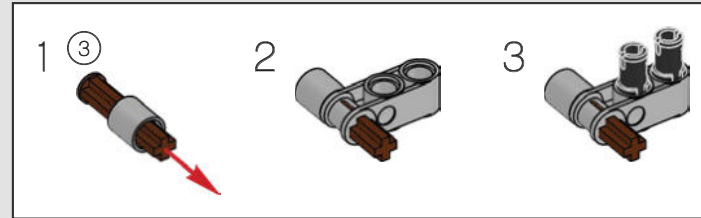
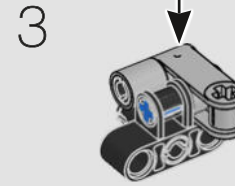
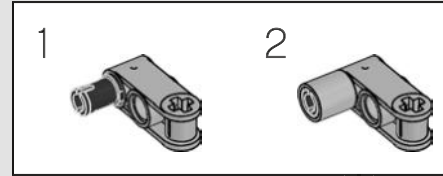
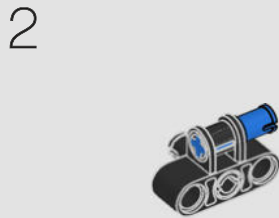
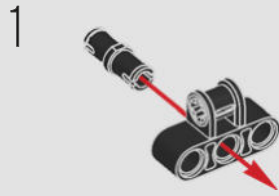

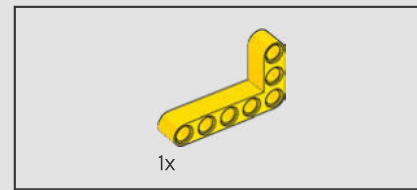
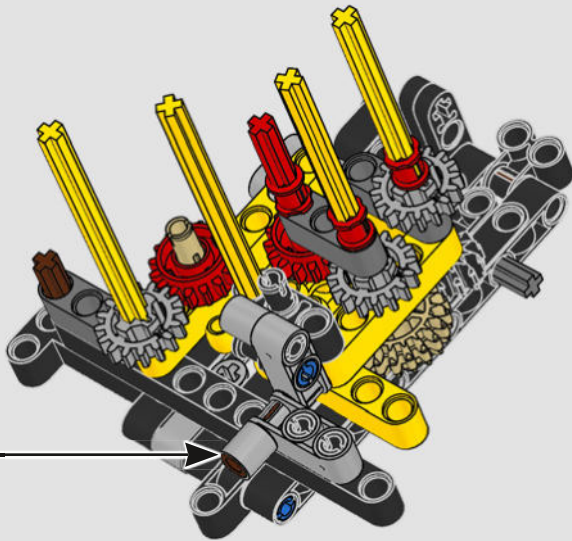

26

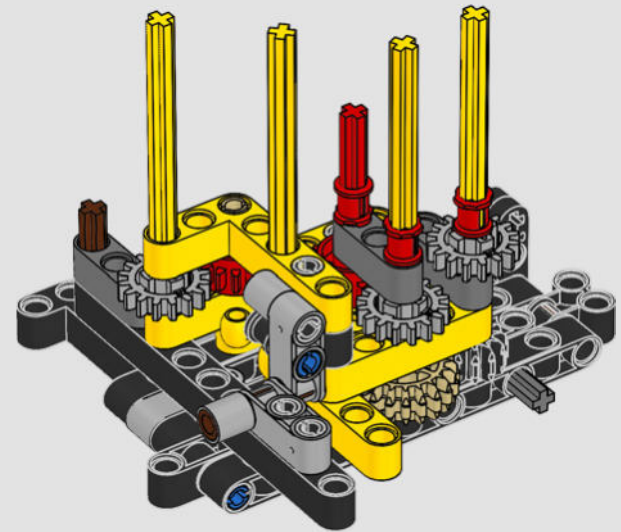



27

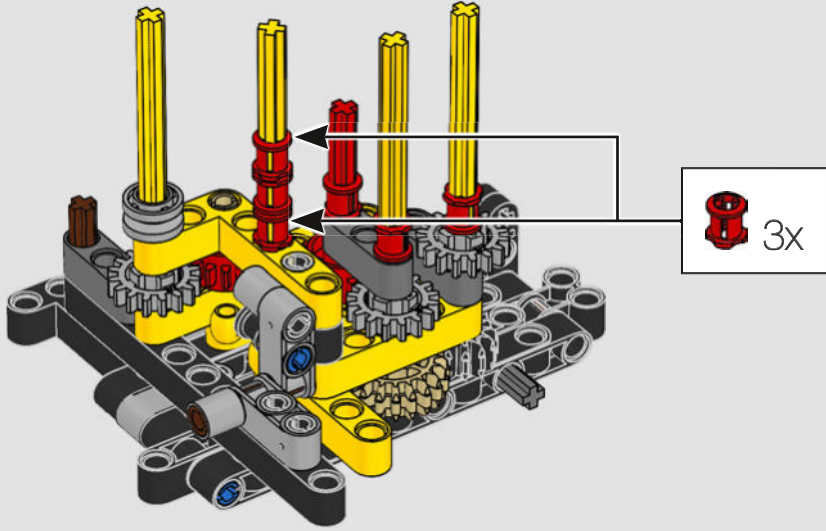

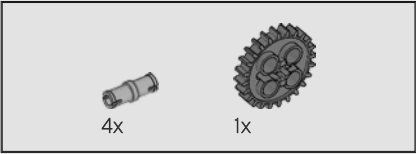
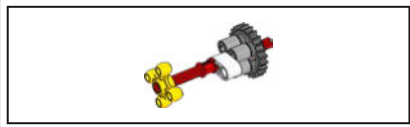

28

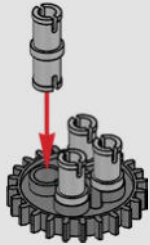

29

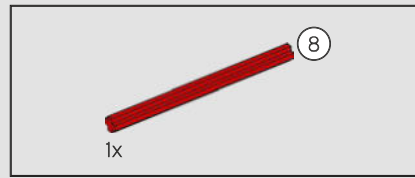
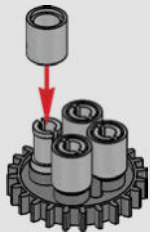

30

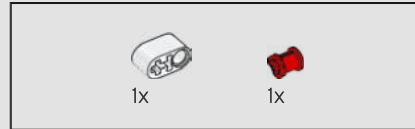
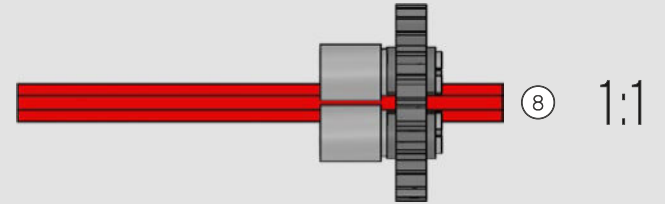
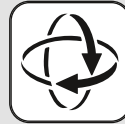

31

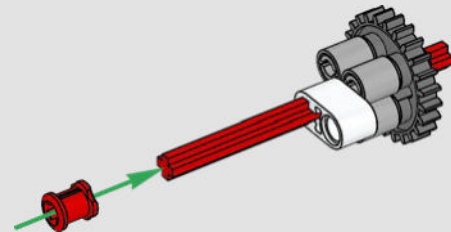



1x

32

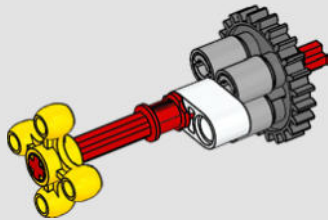

33

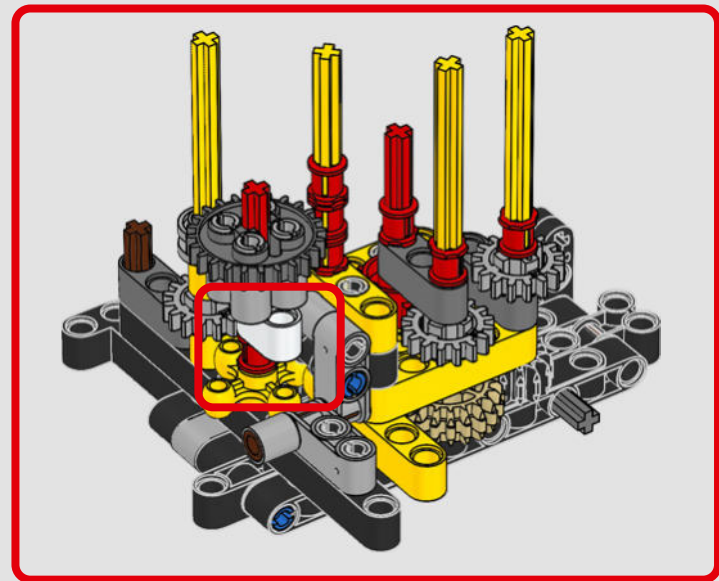
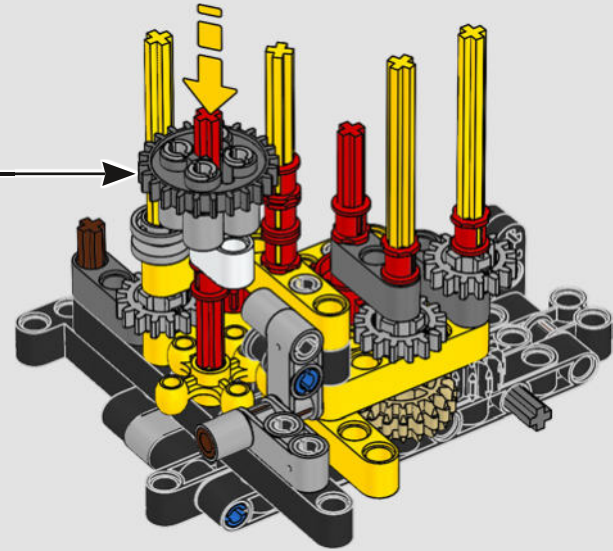

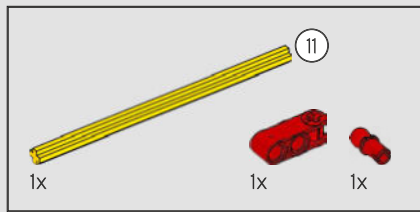

34

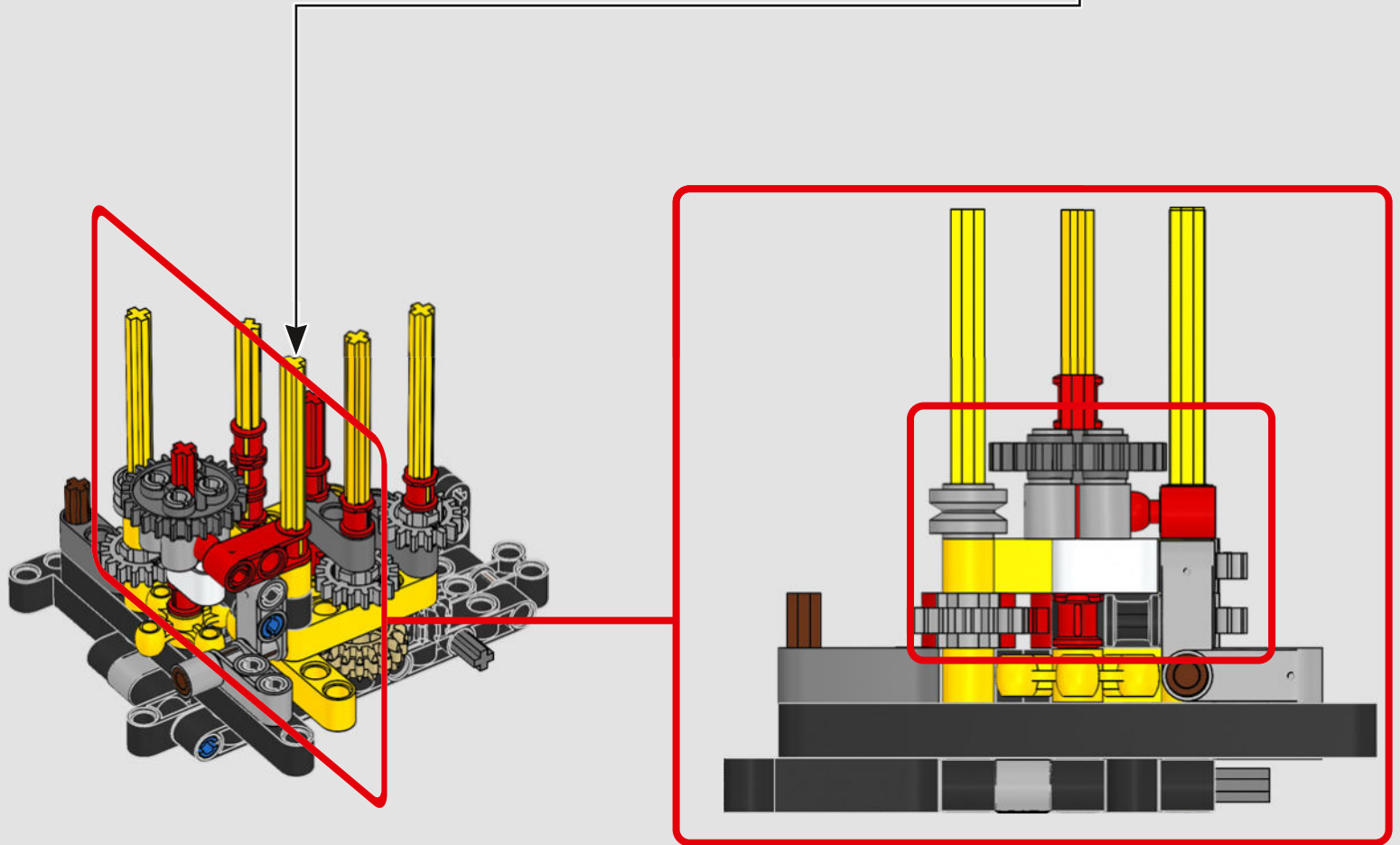
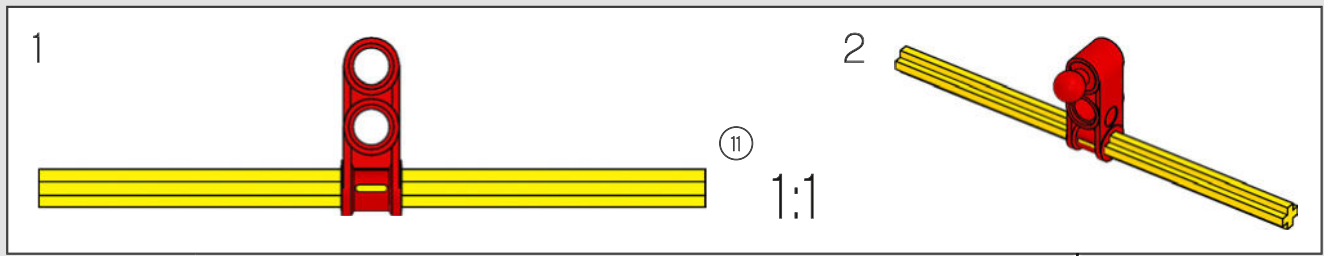

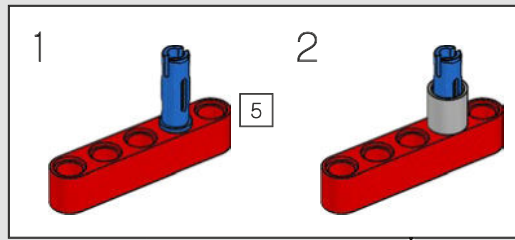
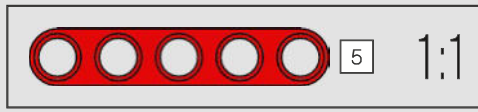
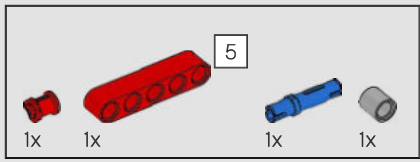

35

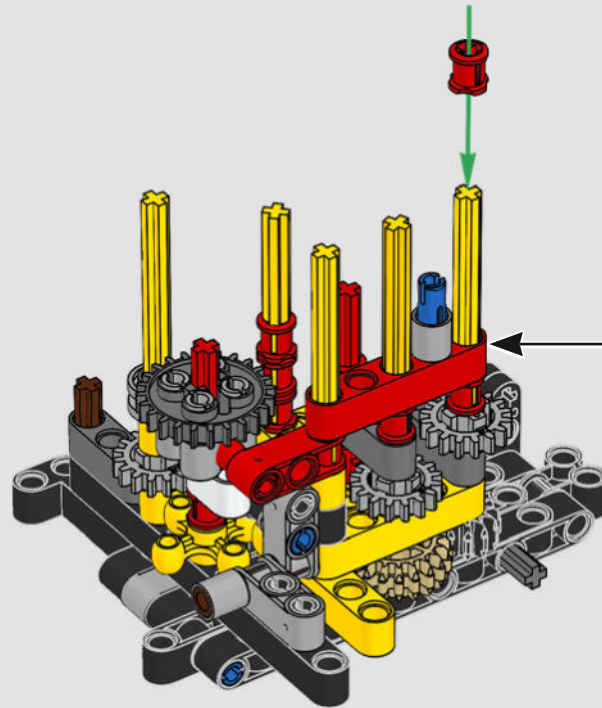

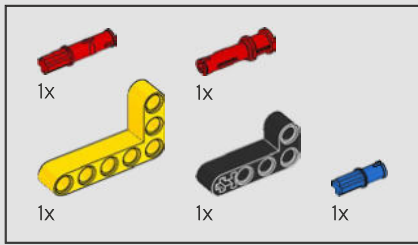

36

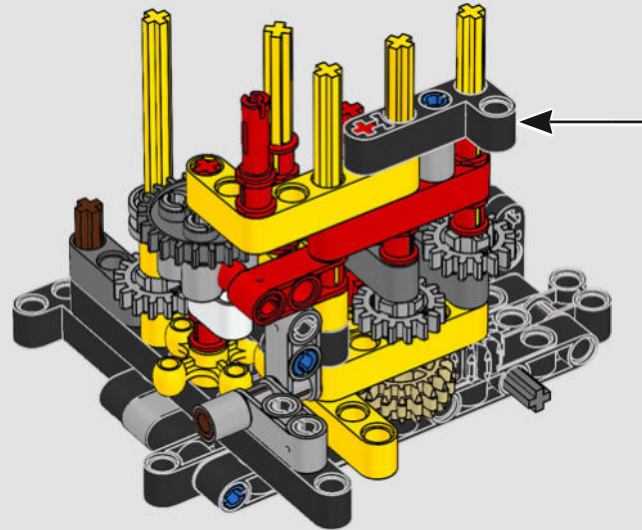
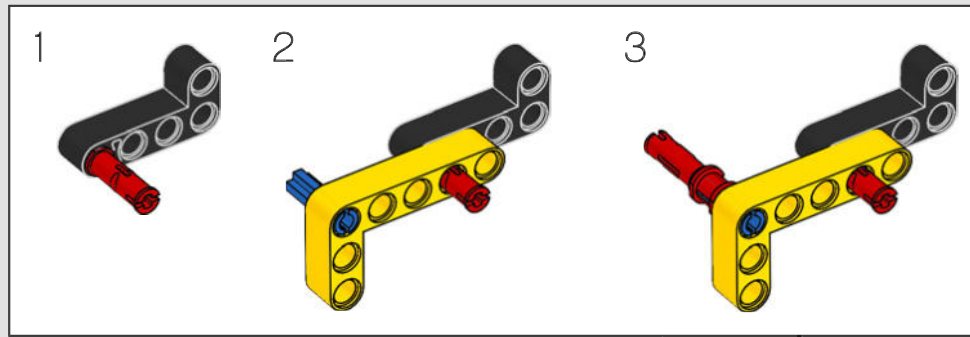

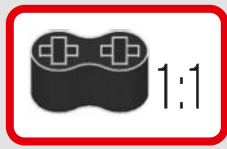
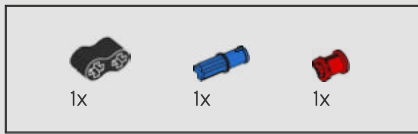

37

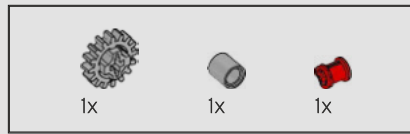
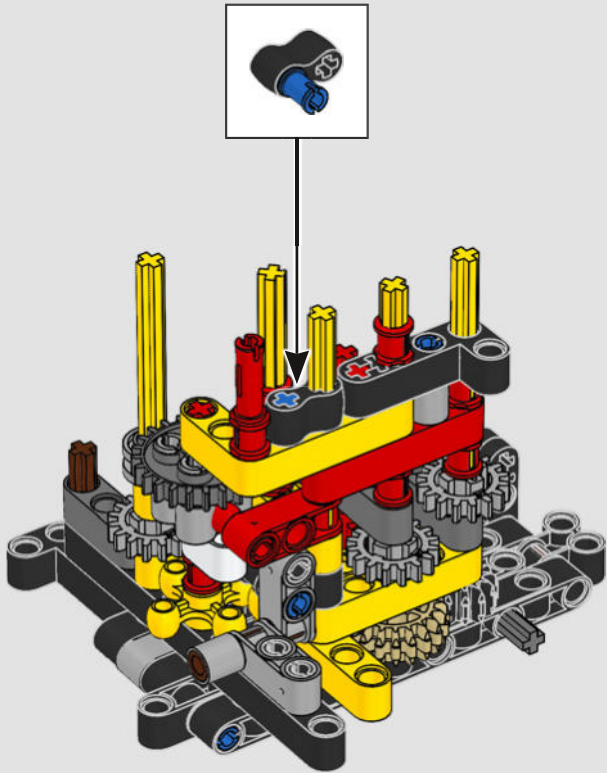

38

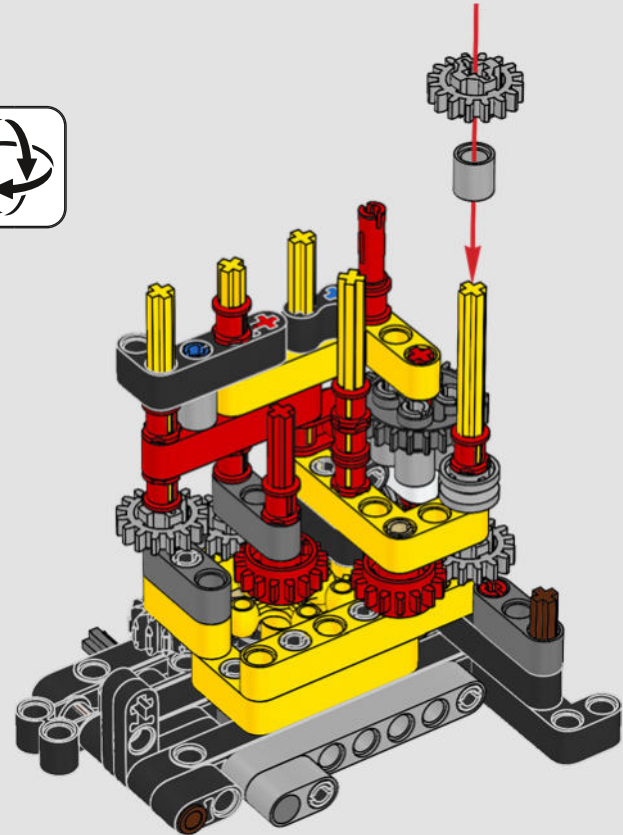
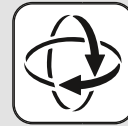

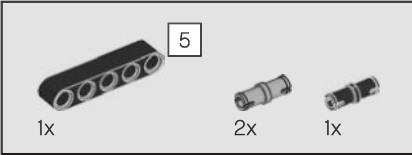
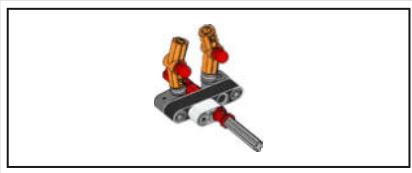

39

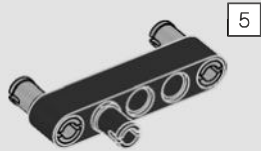

40

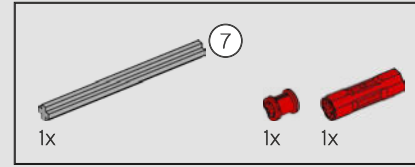
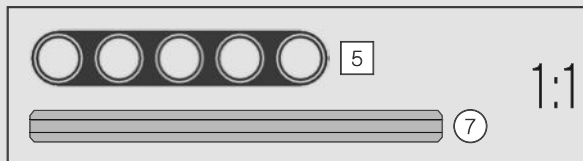

41

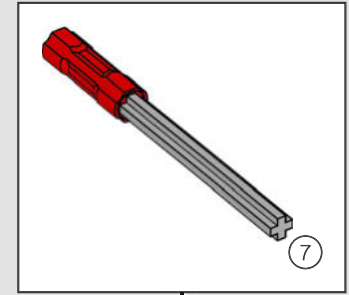

42

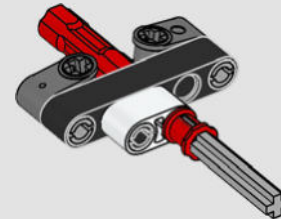
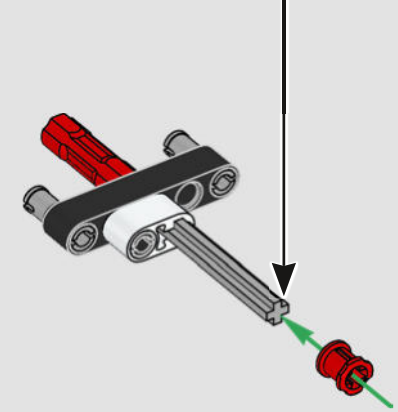

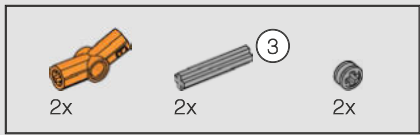

43

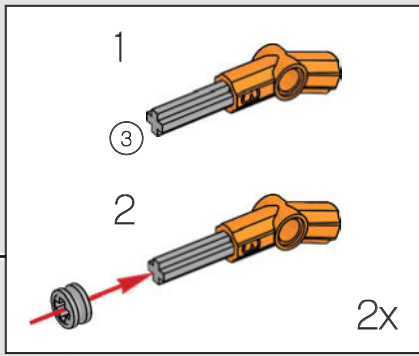
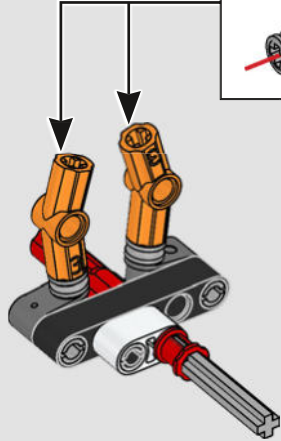

44

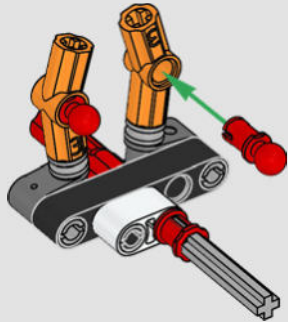

45

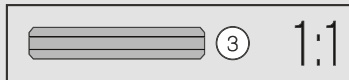
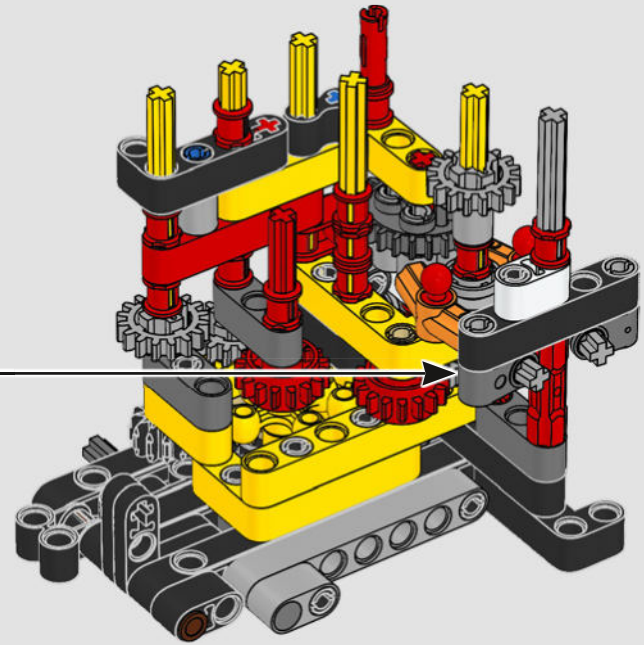



46

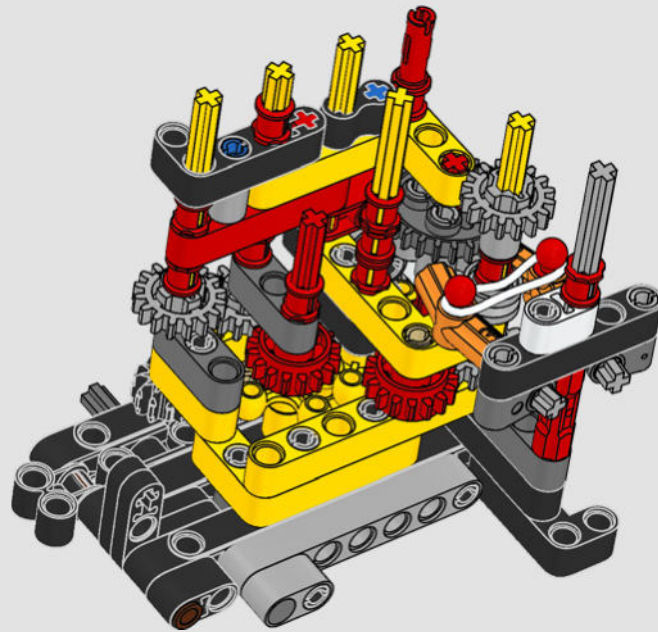

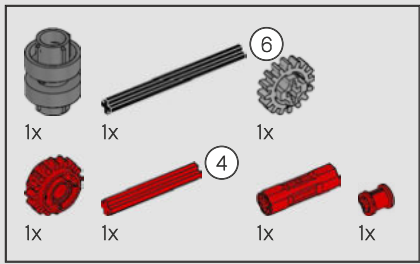

47

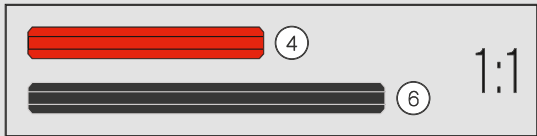
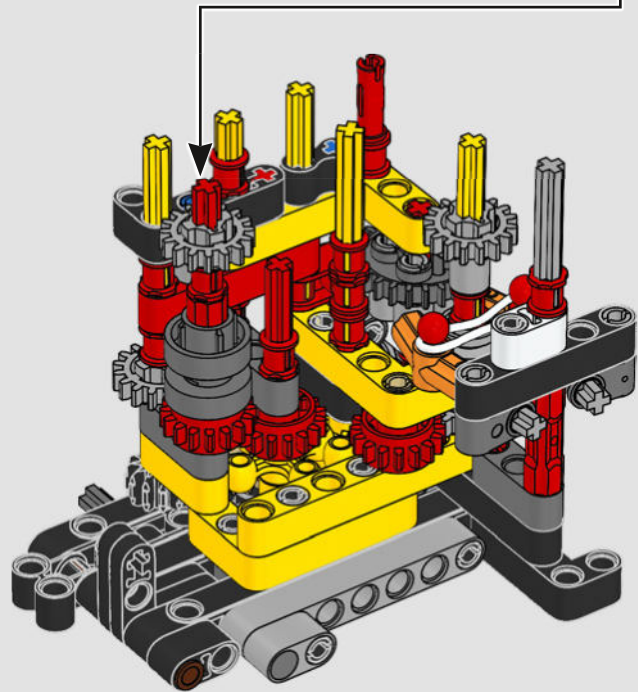
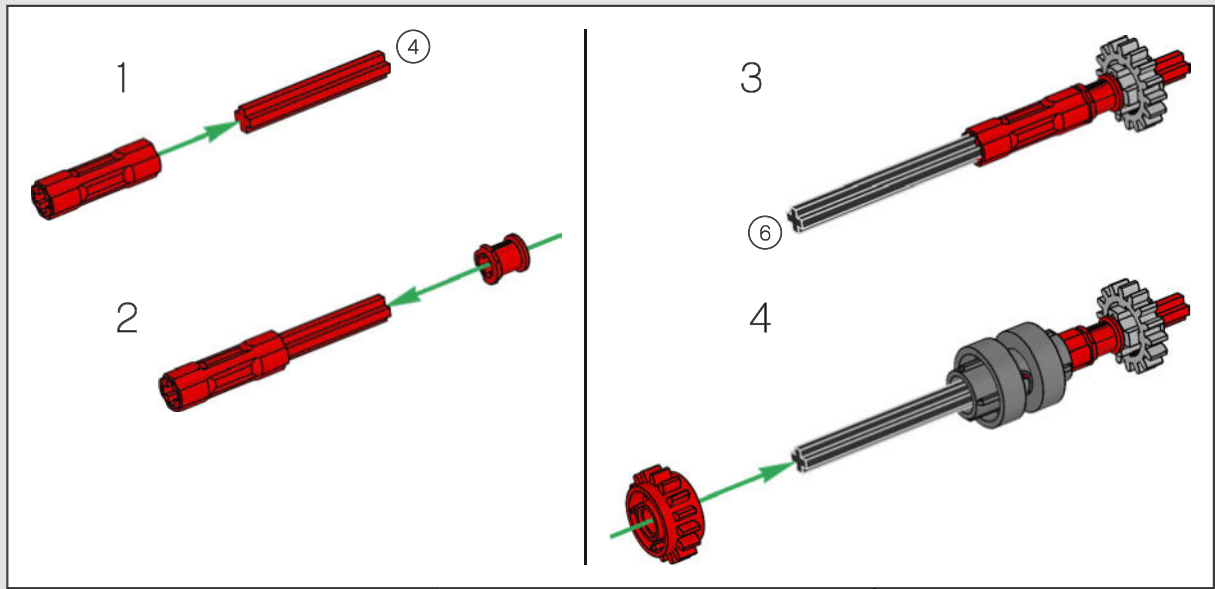



48

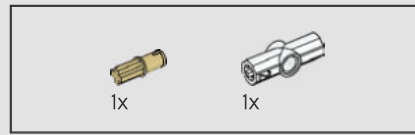
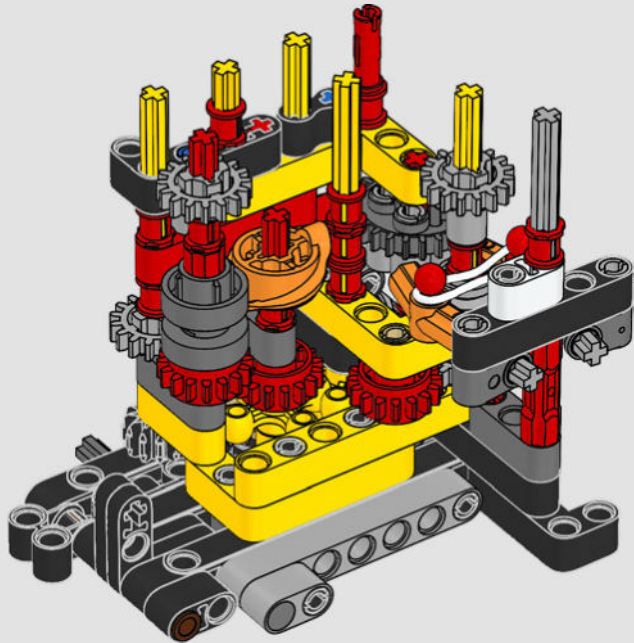
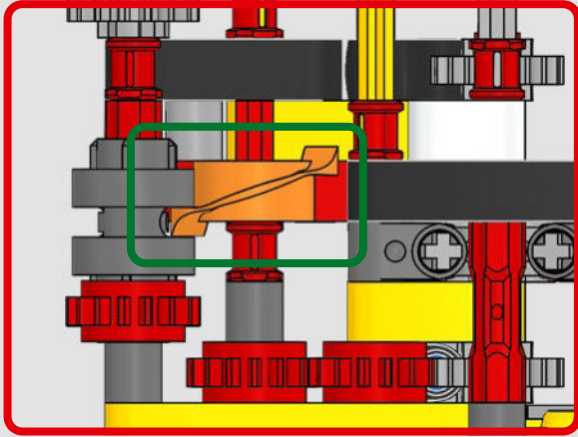

49

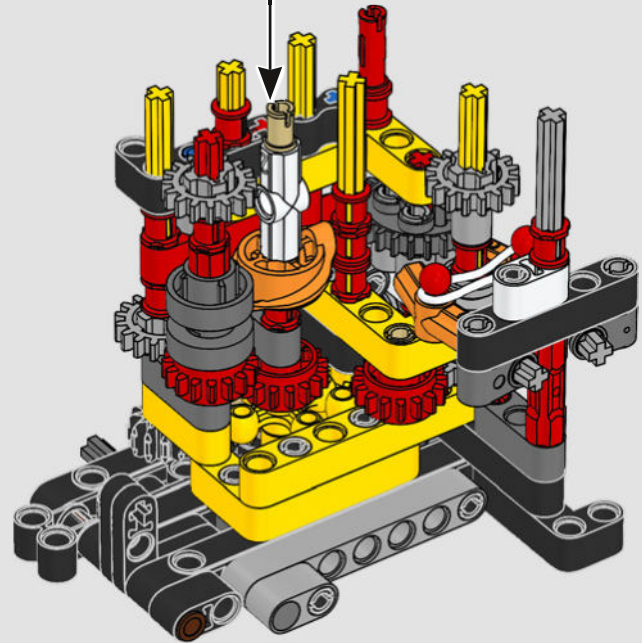
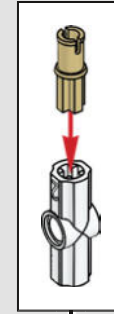



50

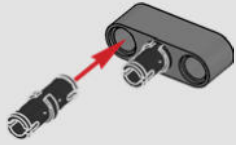

51

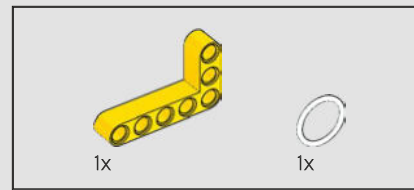
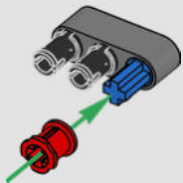

52

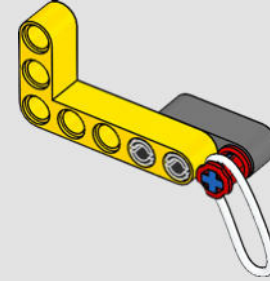

53

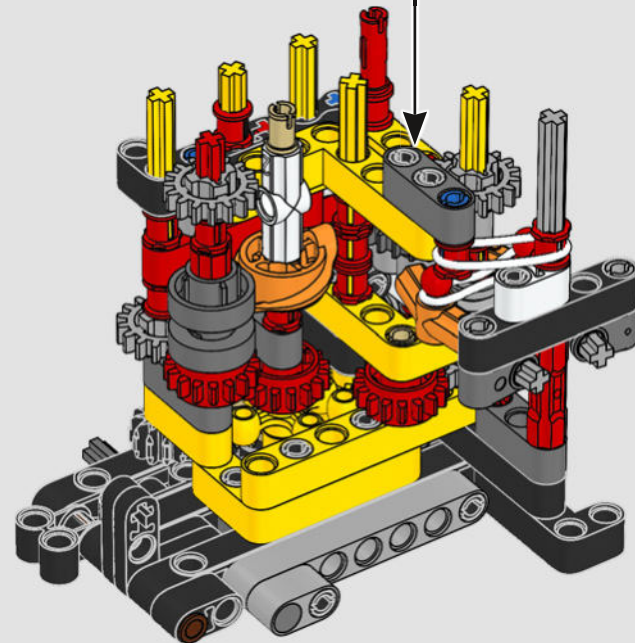

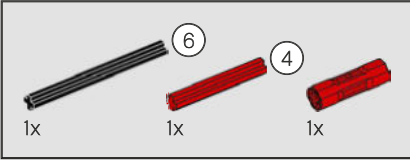
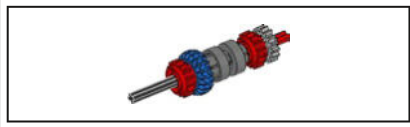

54

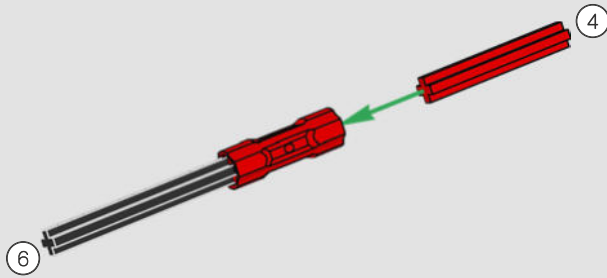

55

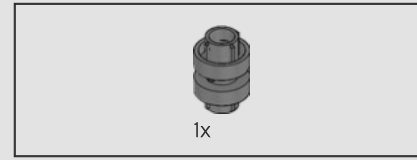
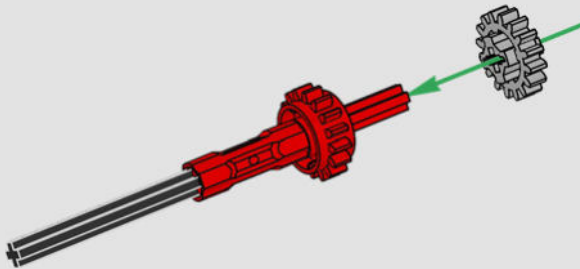

56

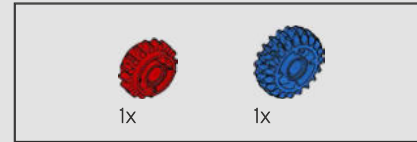
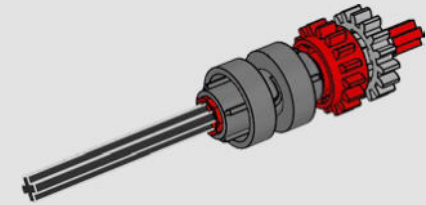

57

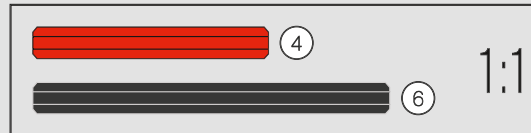
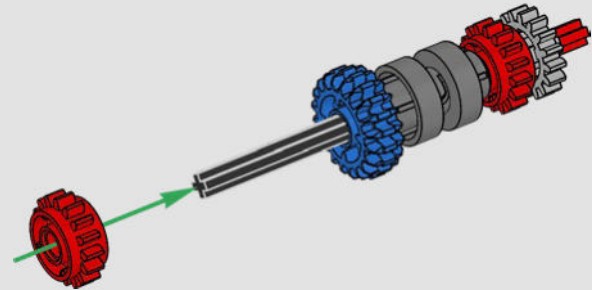

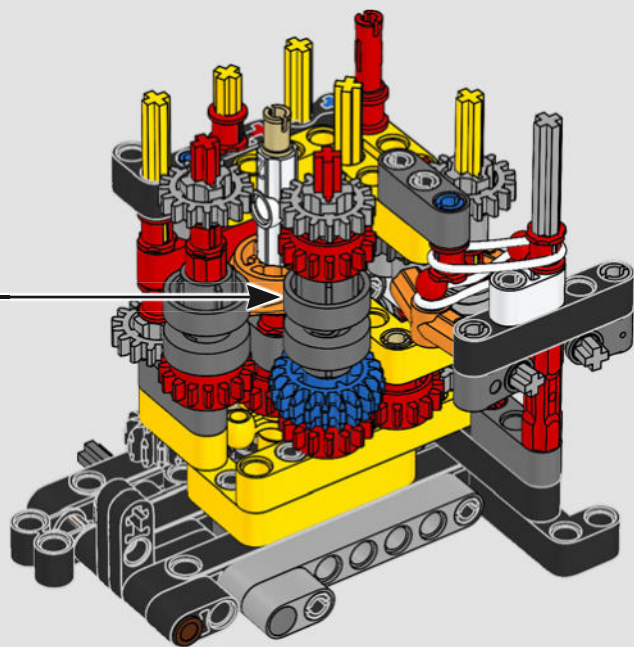

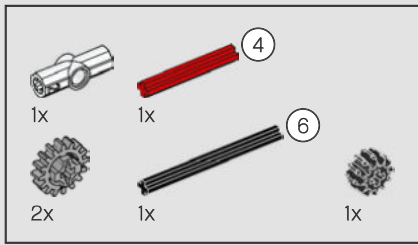

59

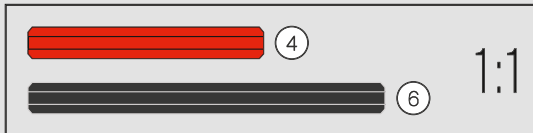
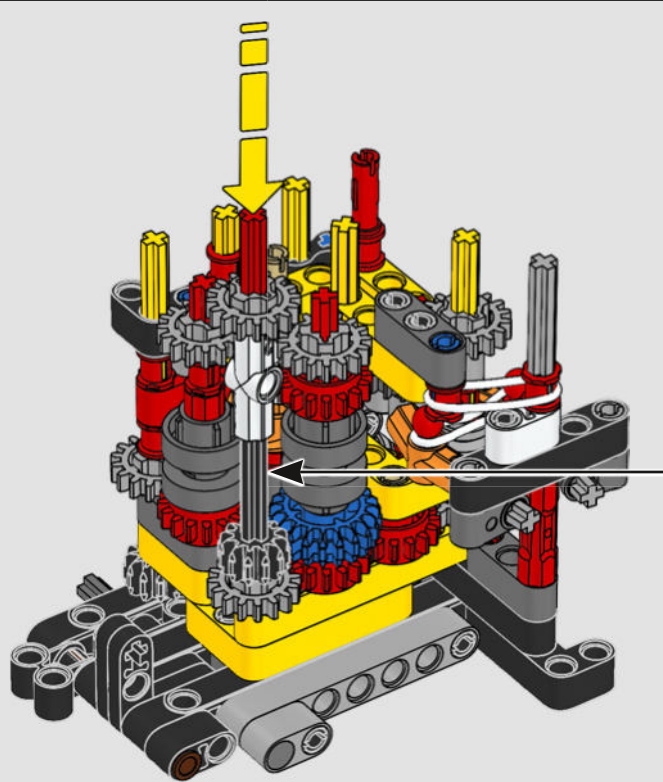
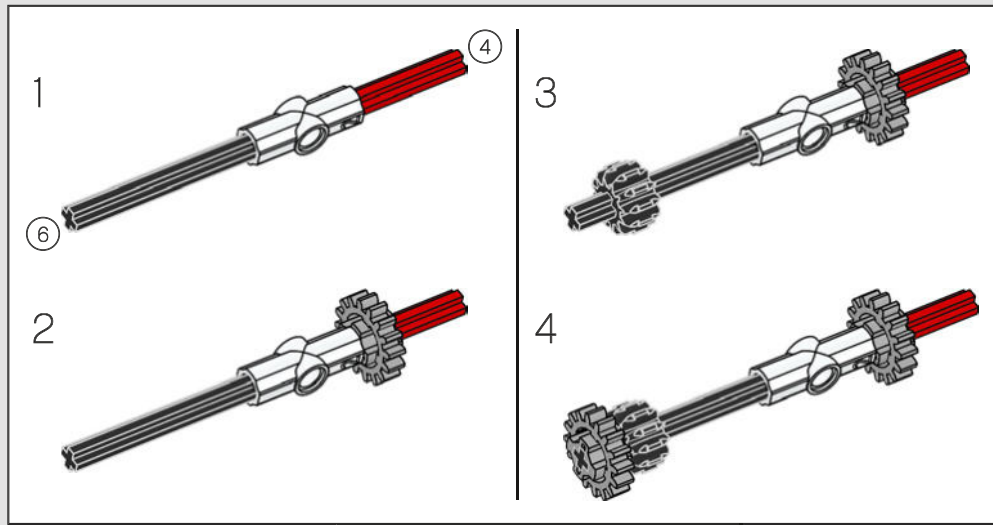

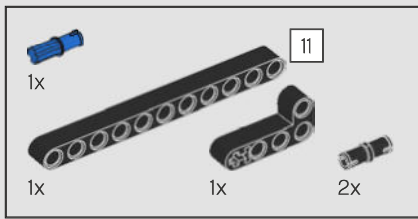

60

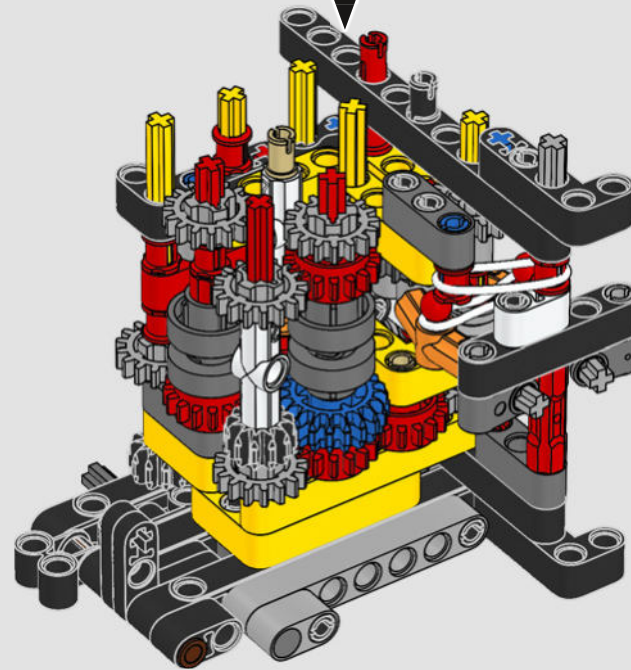
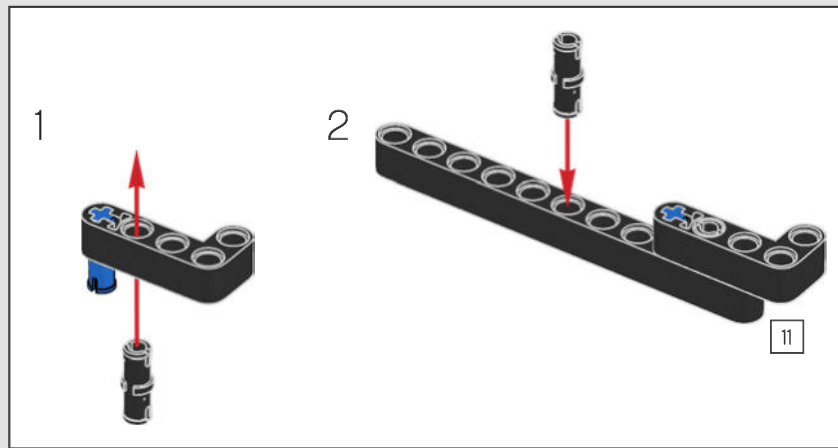

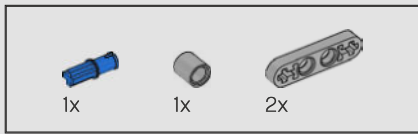

61

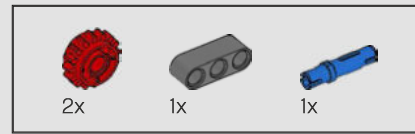
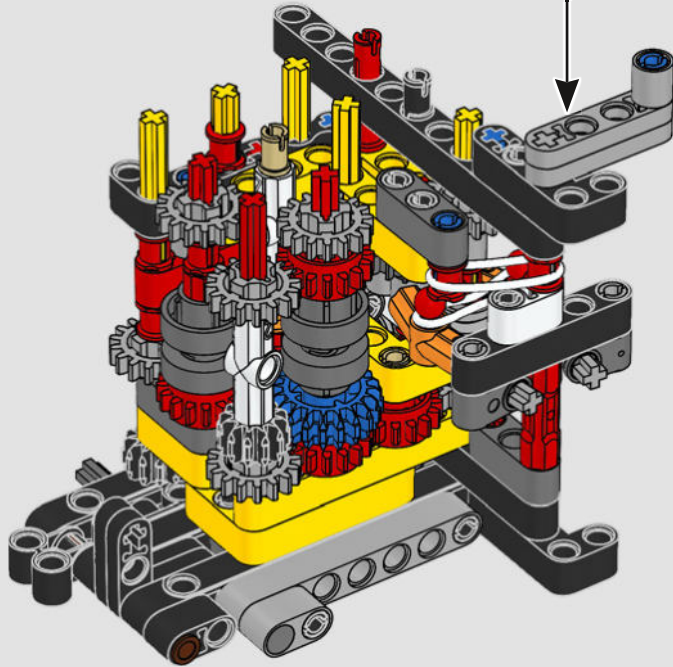
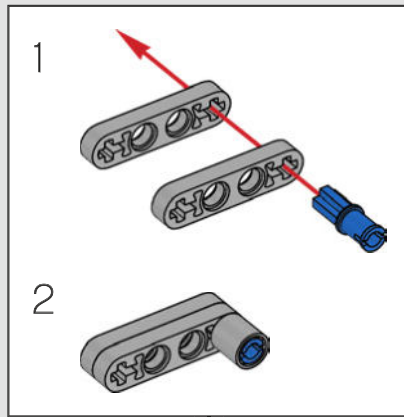

62

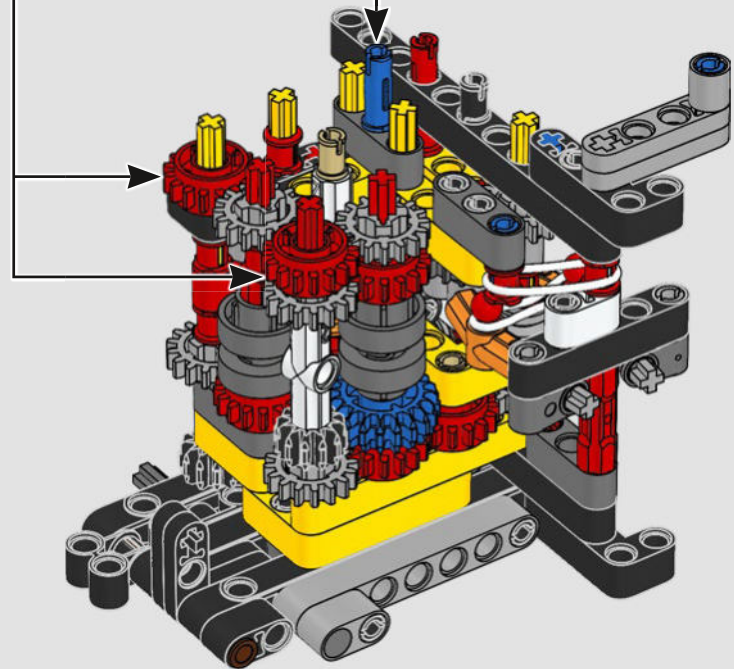
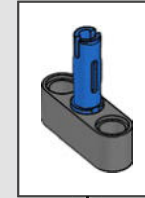

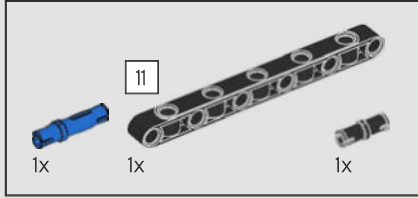
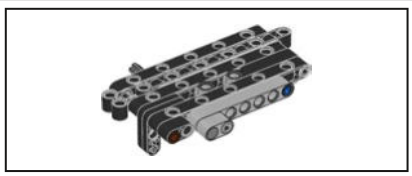

63

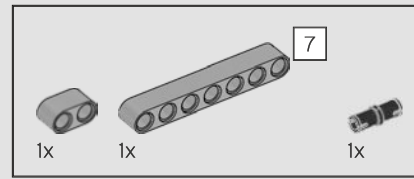
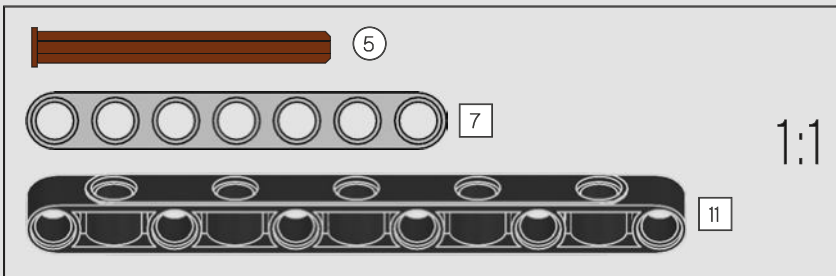
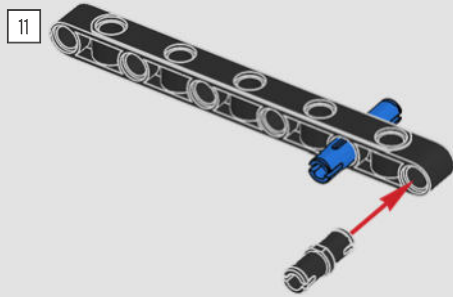

64

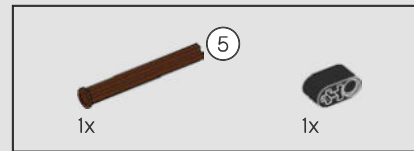
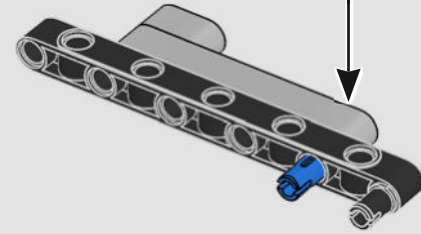
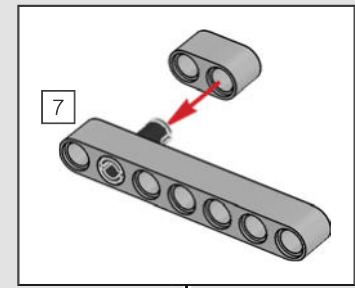

65

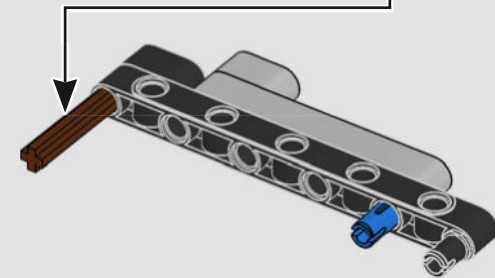
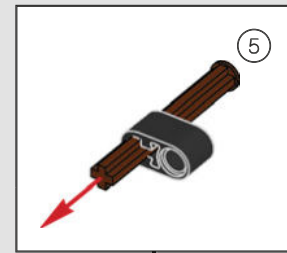



66

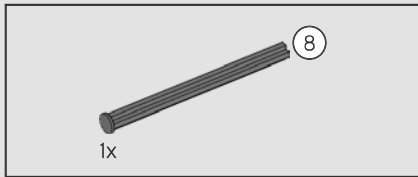
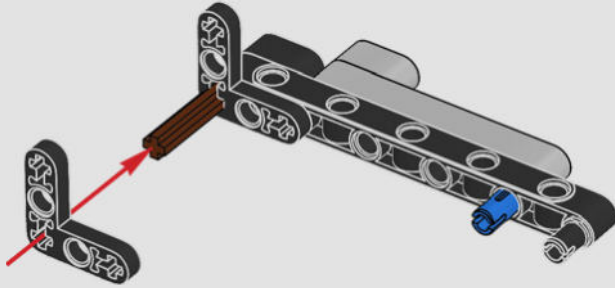

67

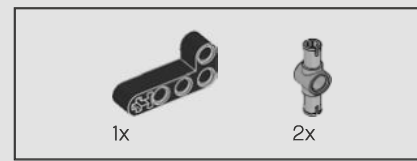
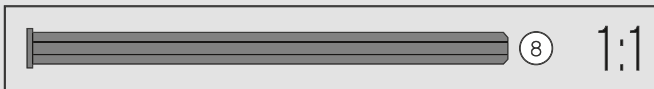
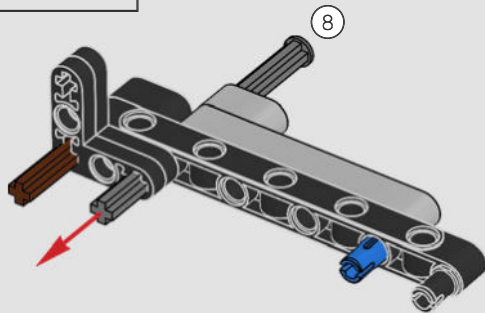

68

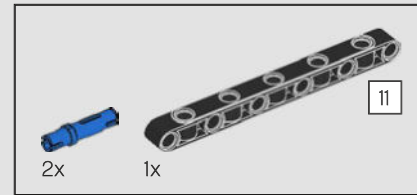
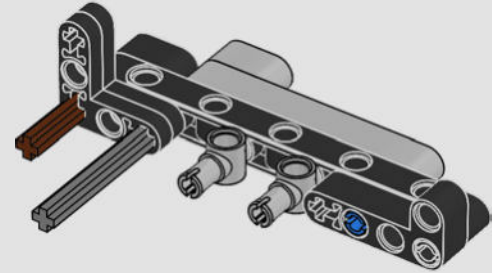

69

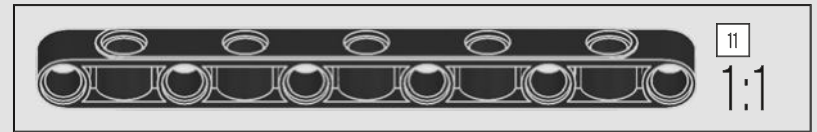
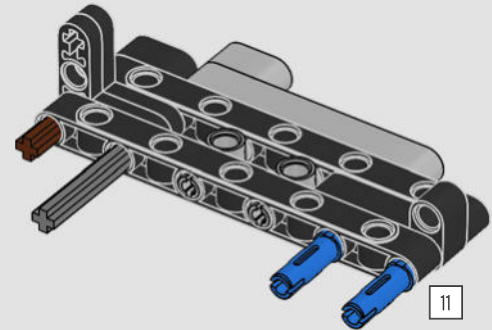

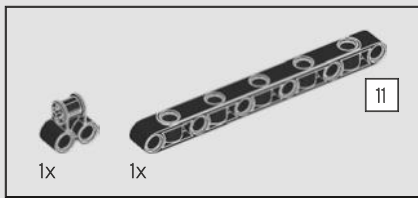

70

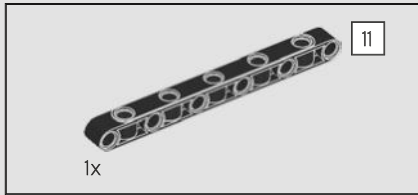
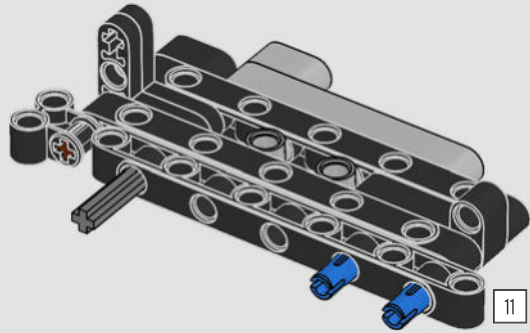

71

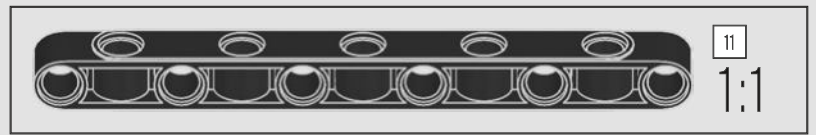
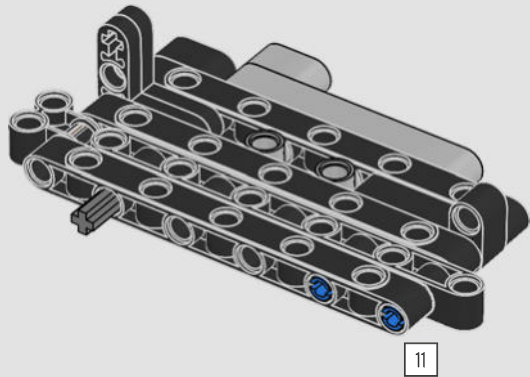

72

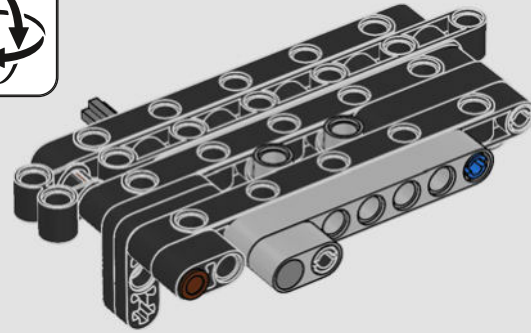

73

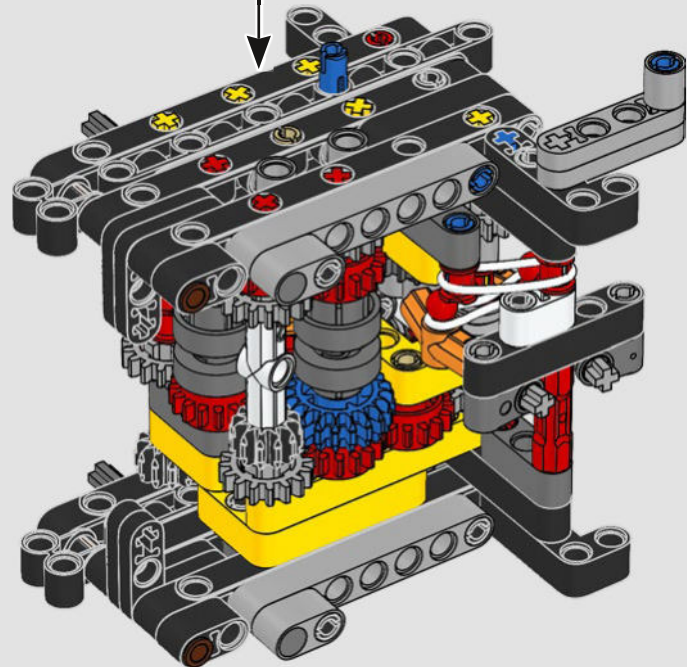

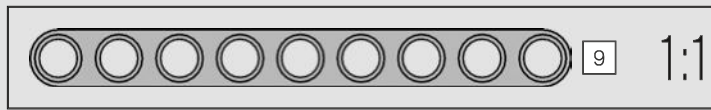
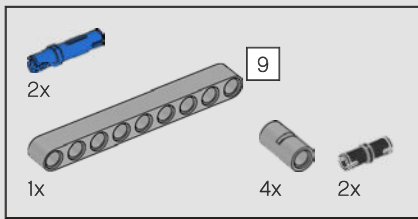

74

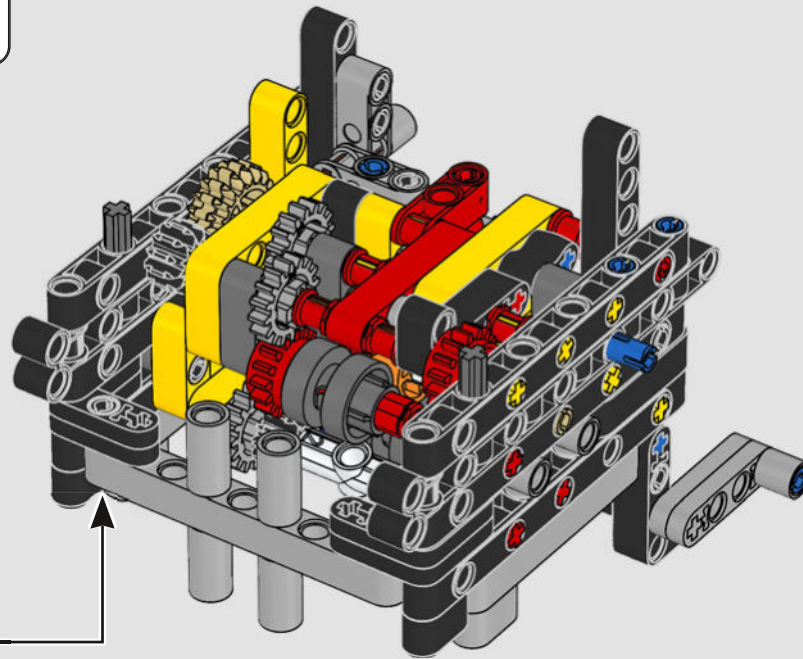
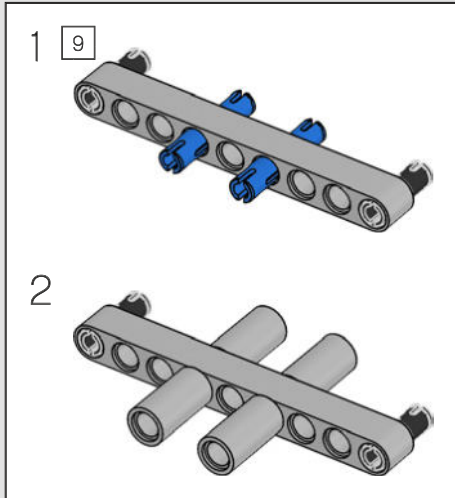

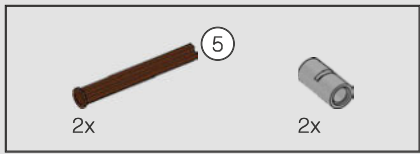

75

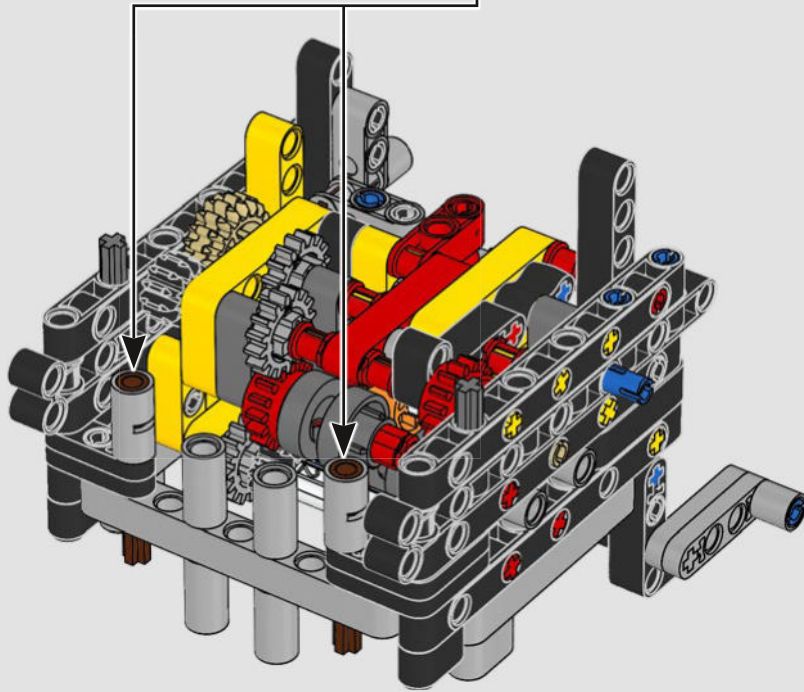
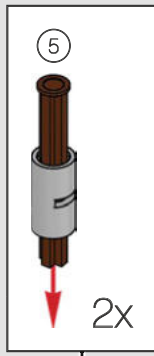

76

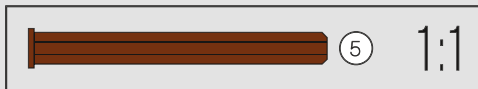
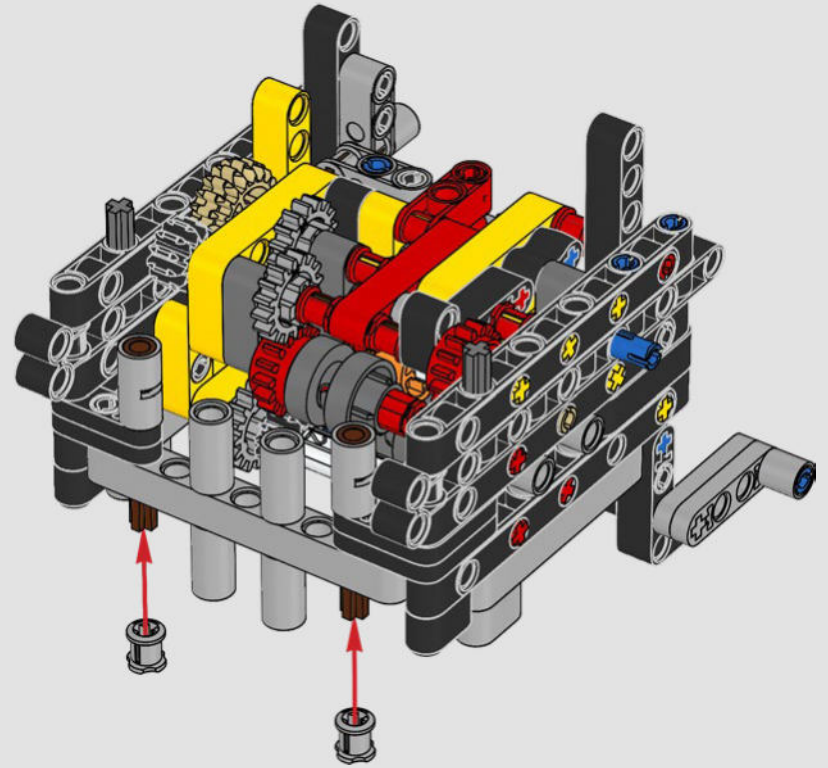

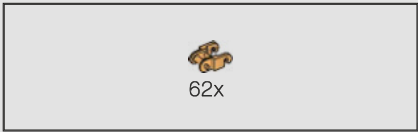

77

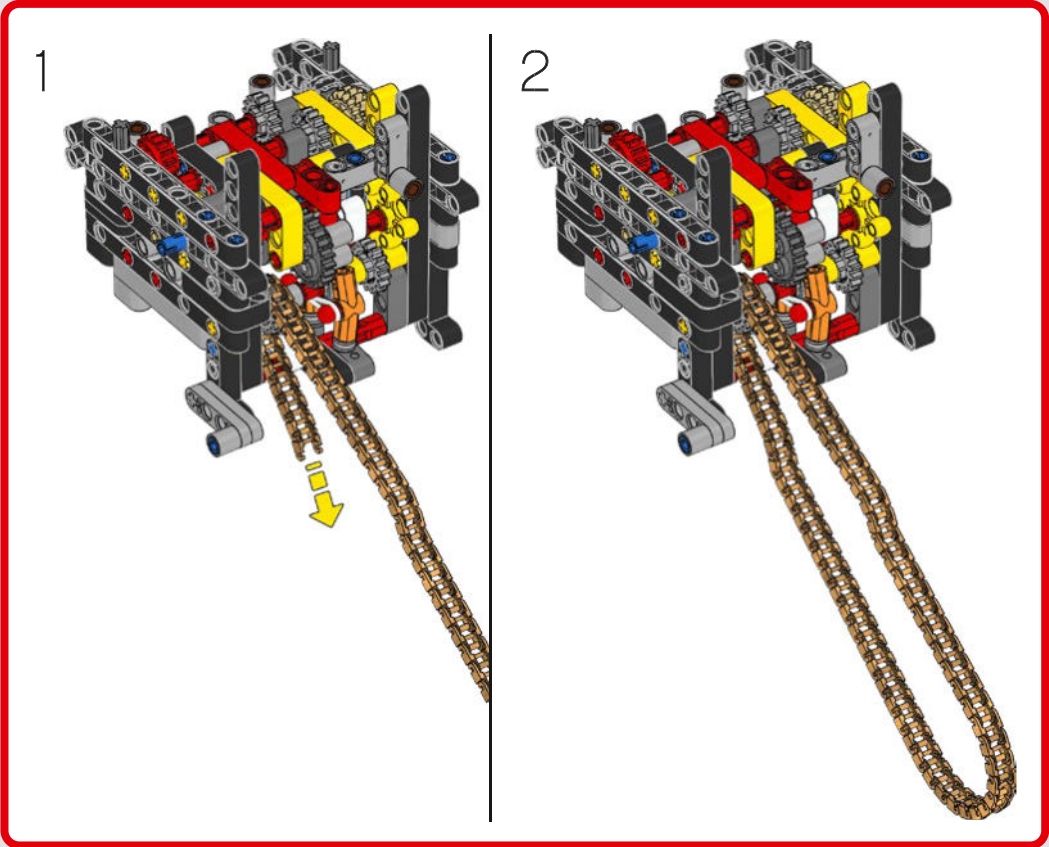
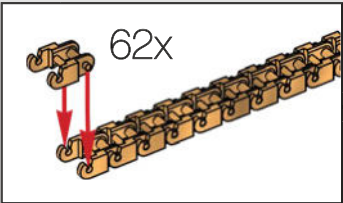
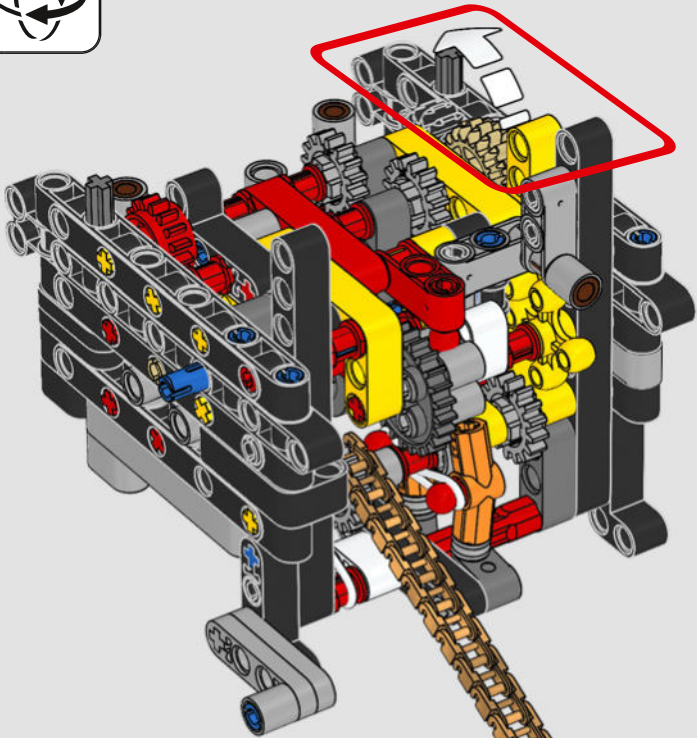

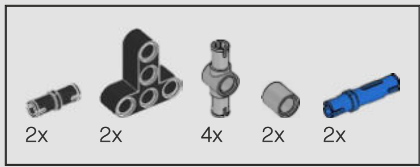

78

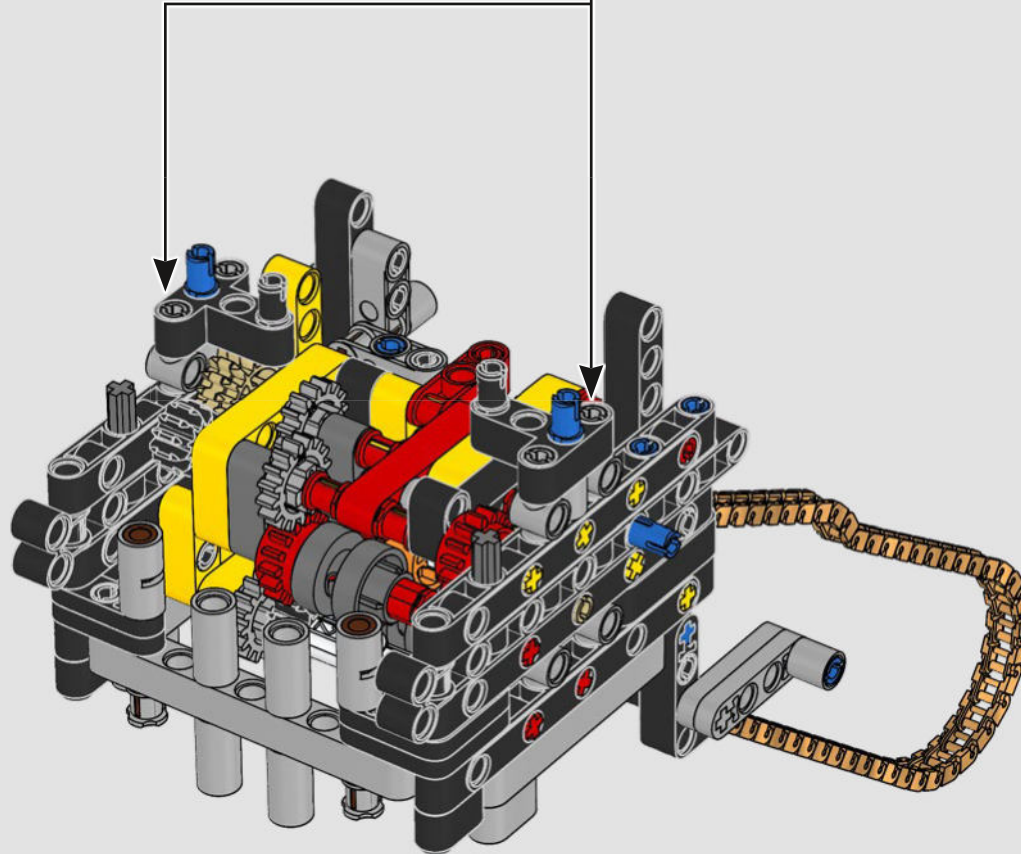
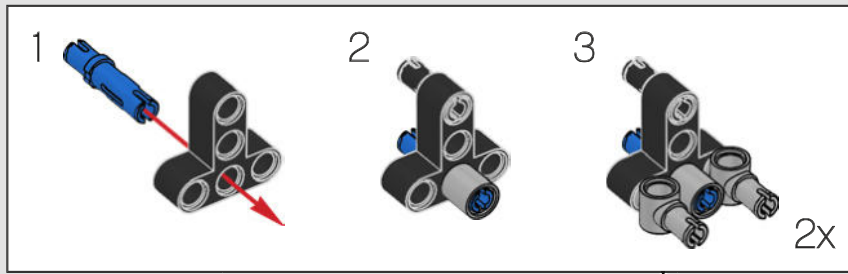

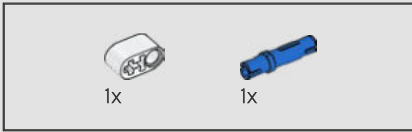
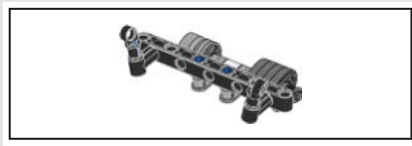

79



80

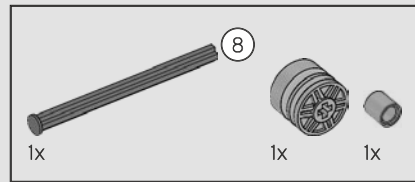
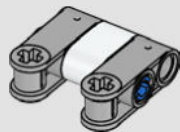

81

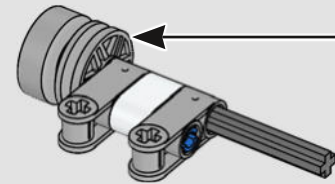
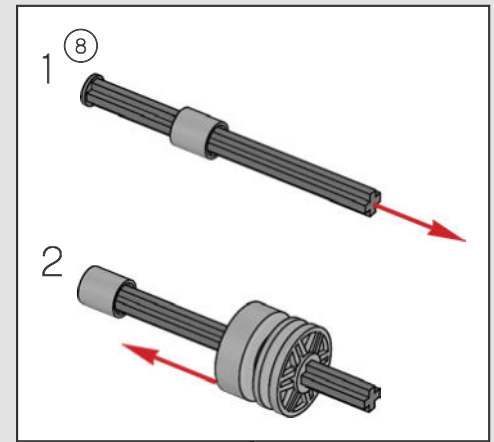

82

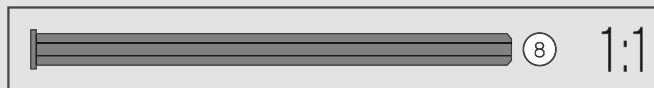
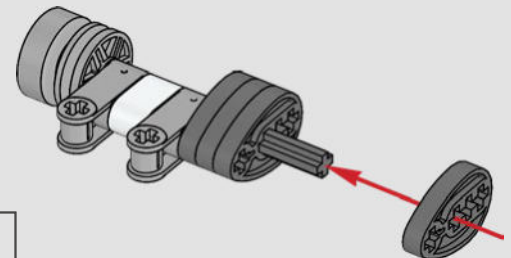

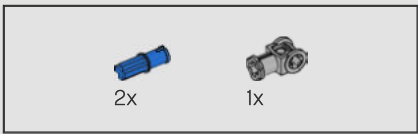

83

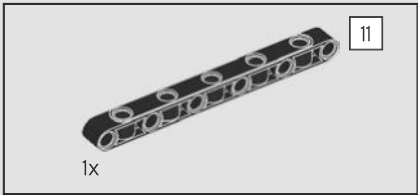
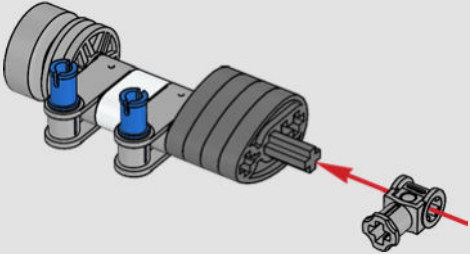

84

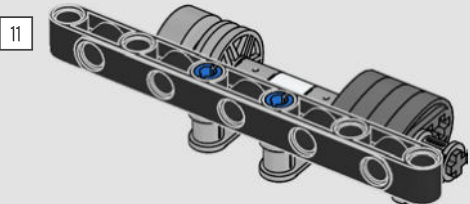

85

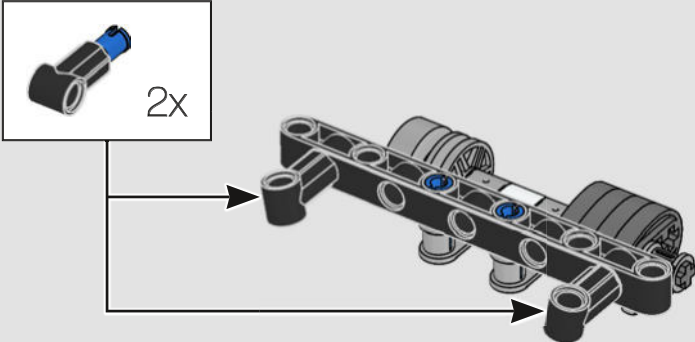

86

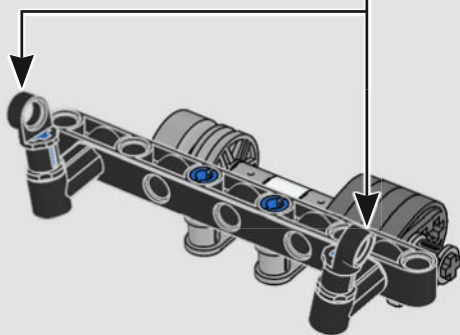
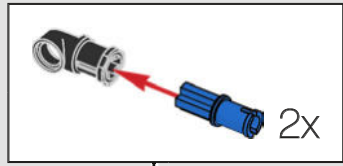

87

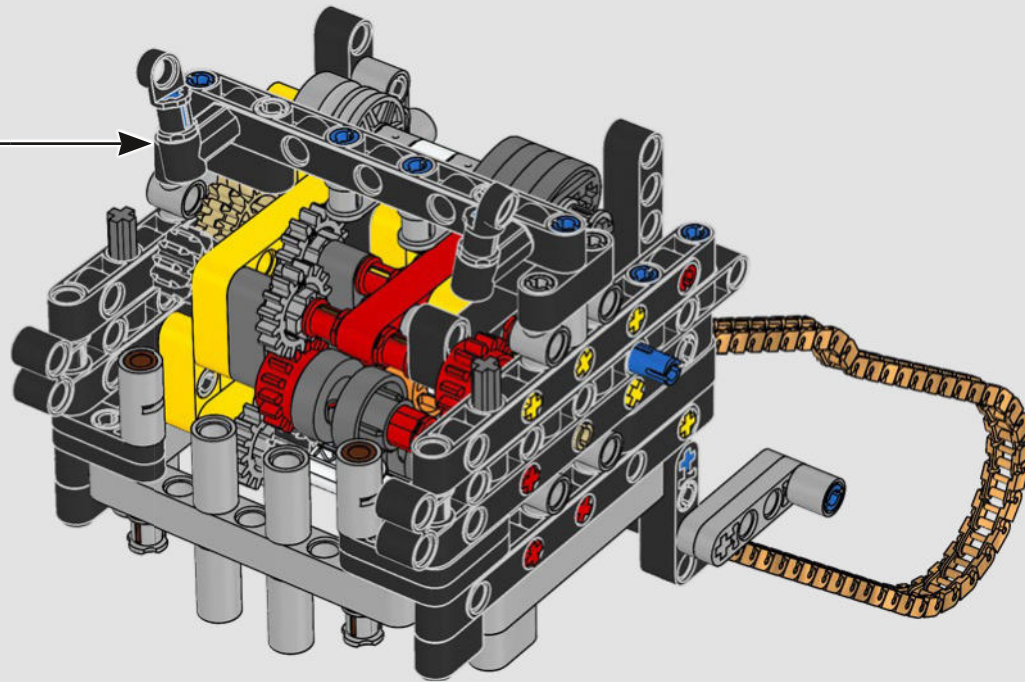

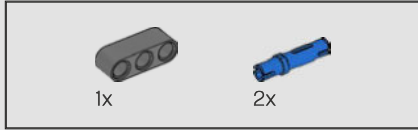
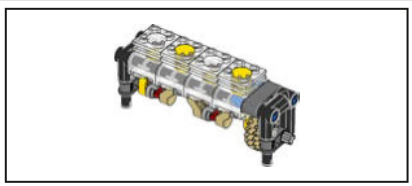

88

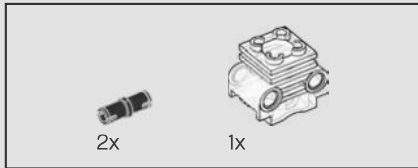
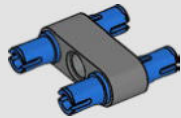

89

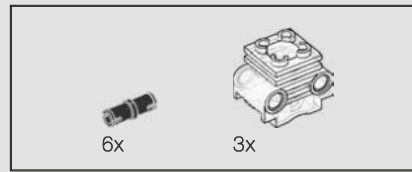
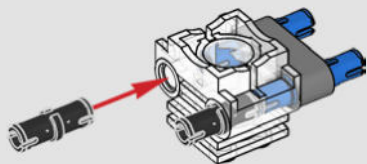

90

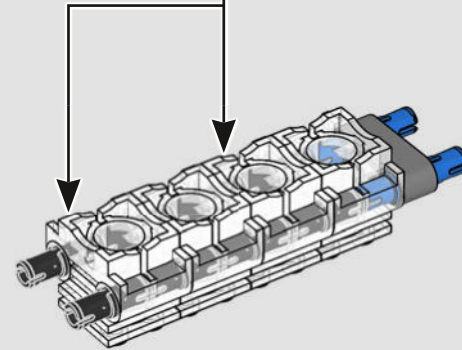
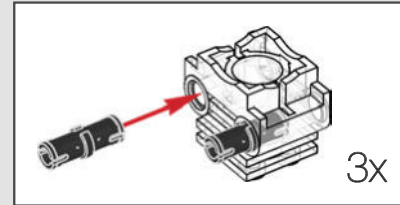

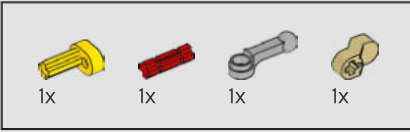
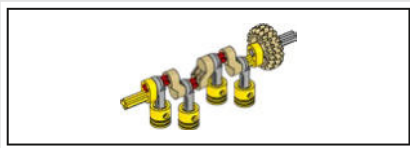

91

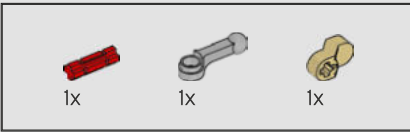
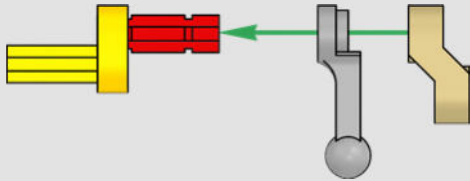

92

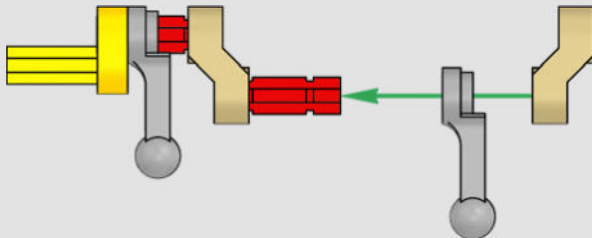

93

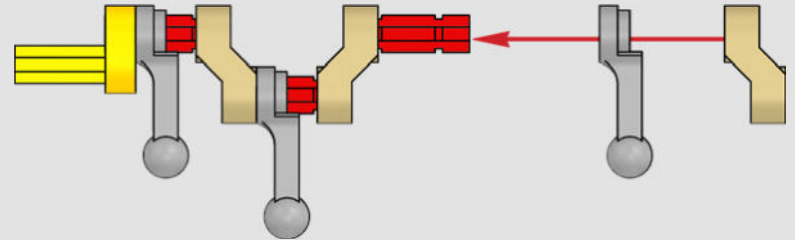

94

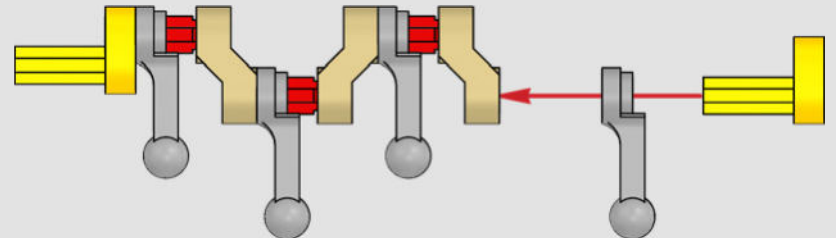



4x

95

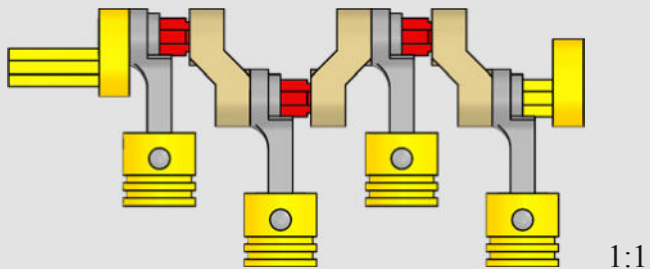

1:1

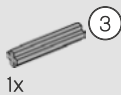

3

1x



1x

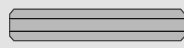

3

1:1

96

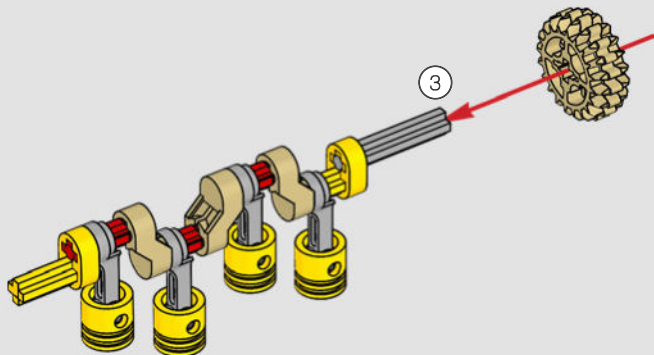

3

97

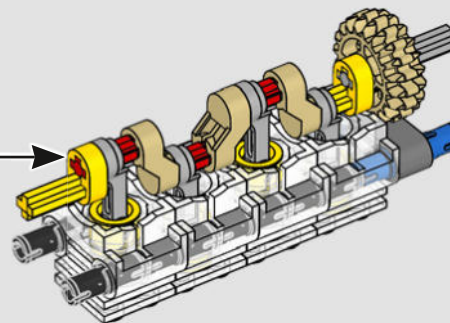

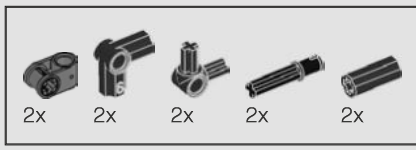

98

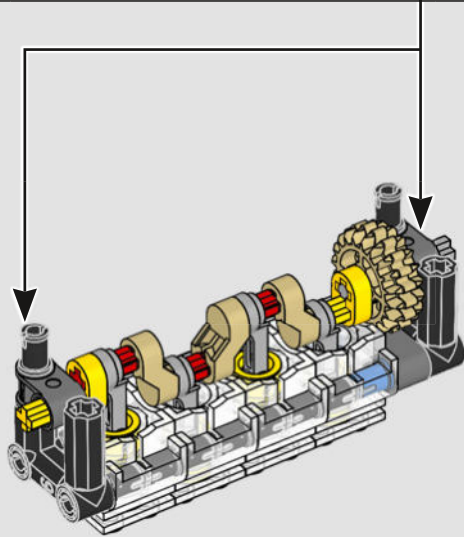
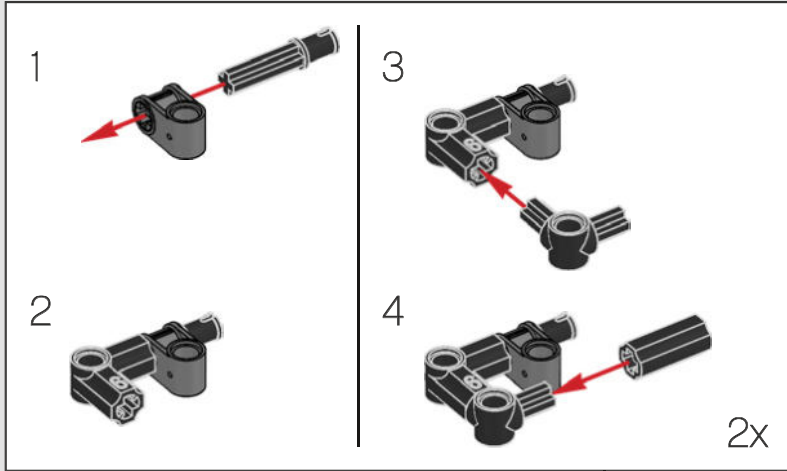

99

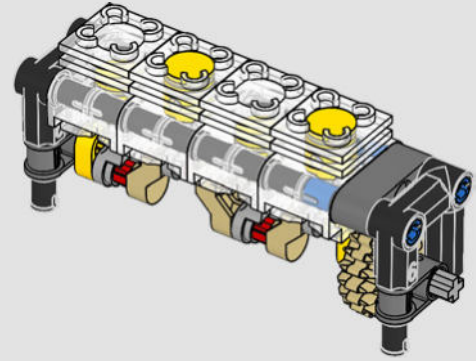

100

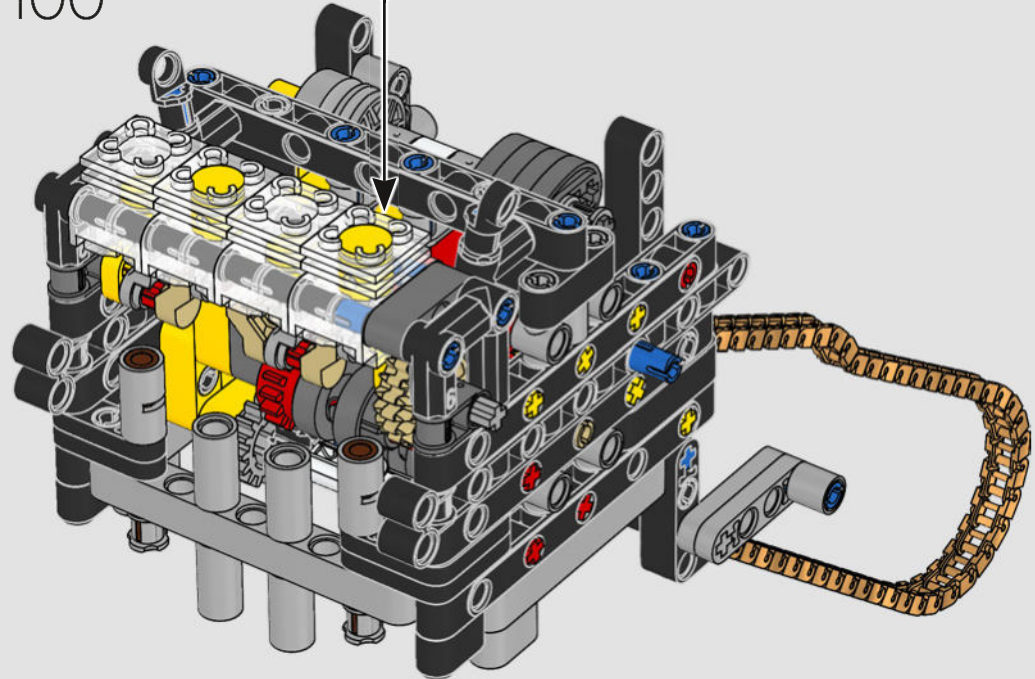

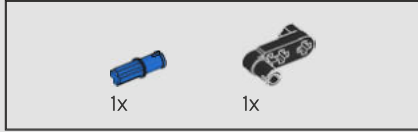
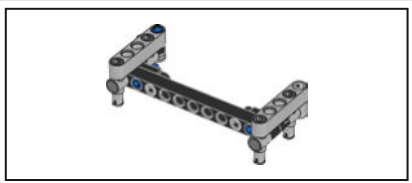

101

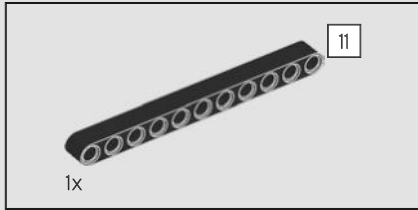

102

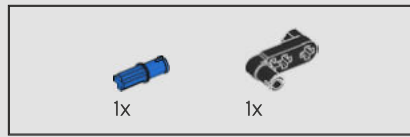
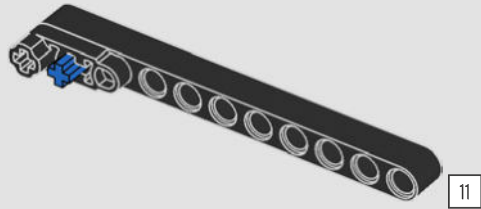

103

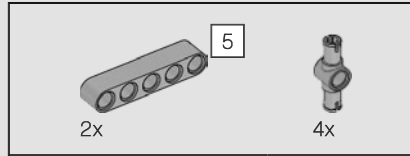
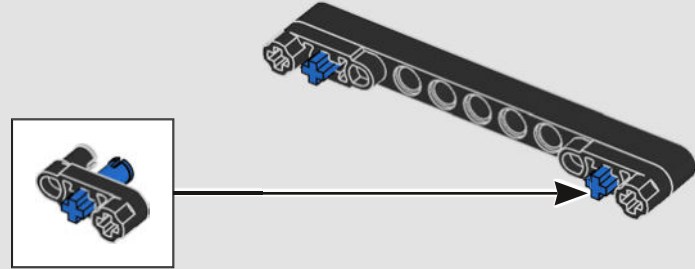

104

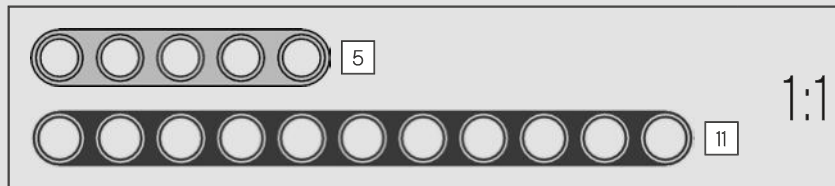
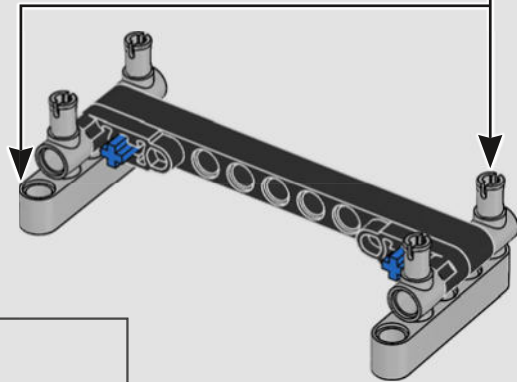
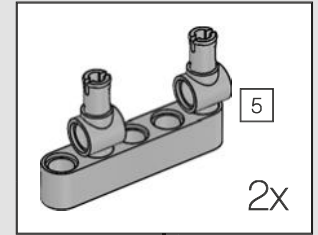

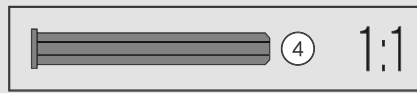
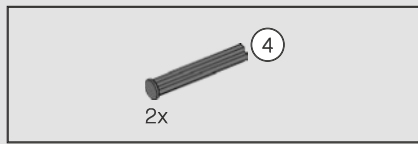

105

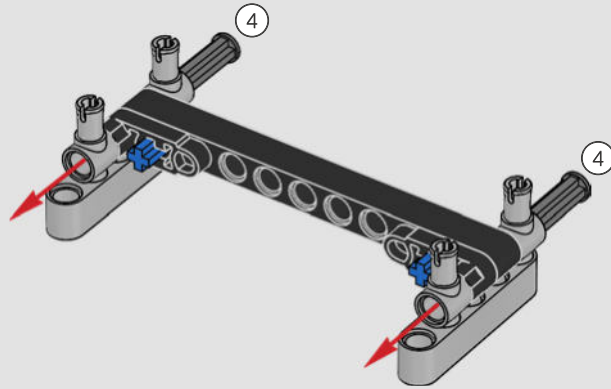

106

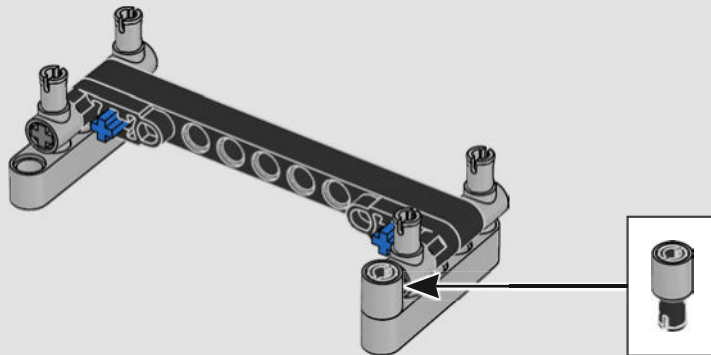

107

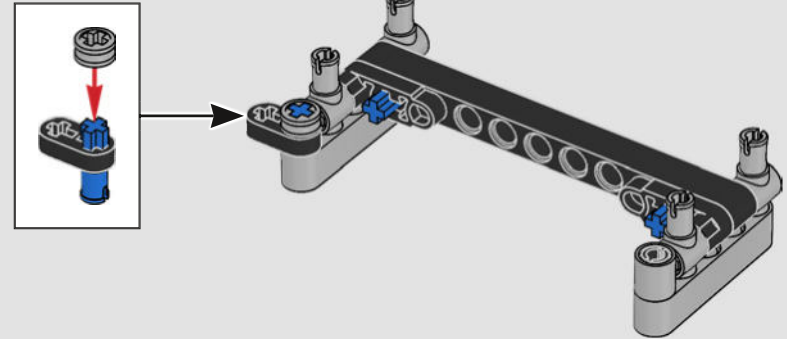

108

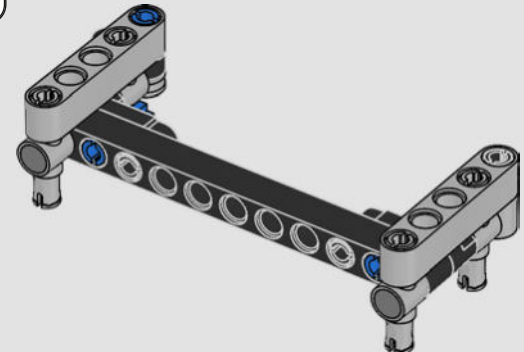

109

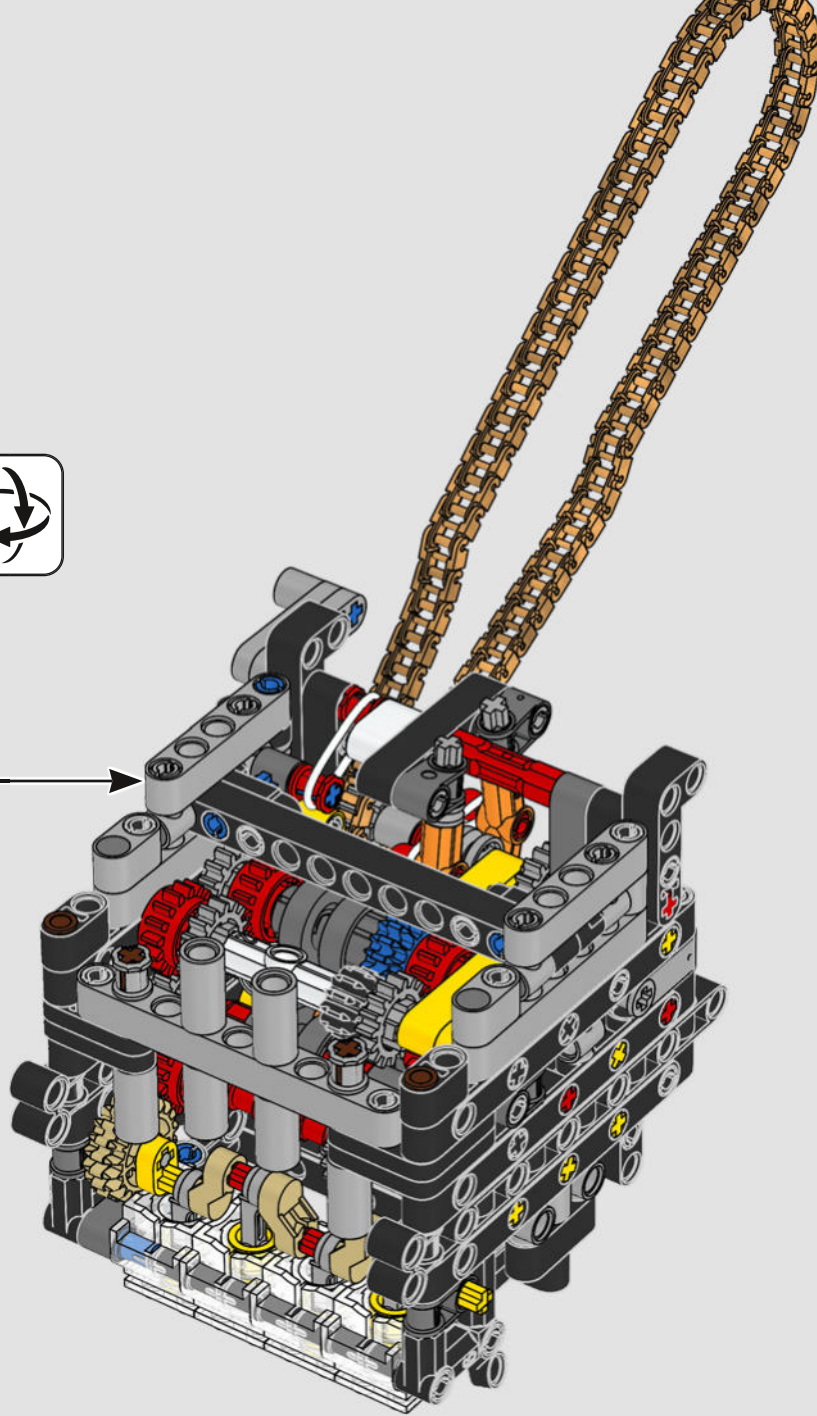

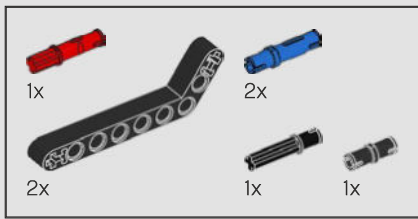

110

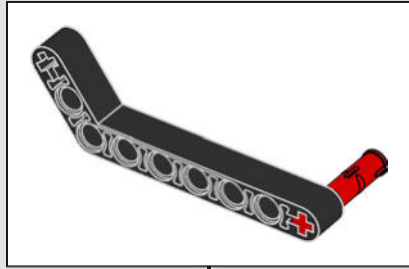

1

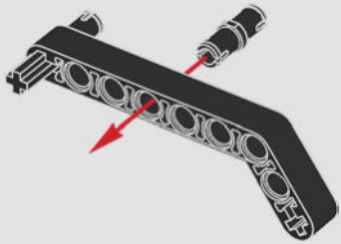

2

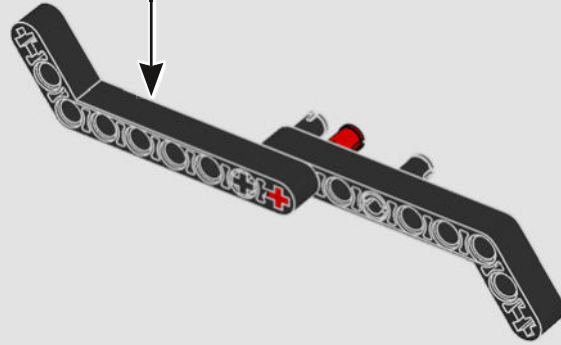

3

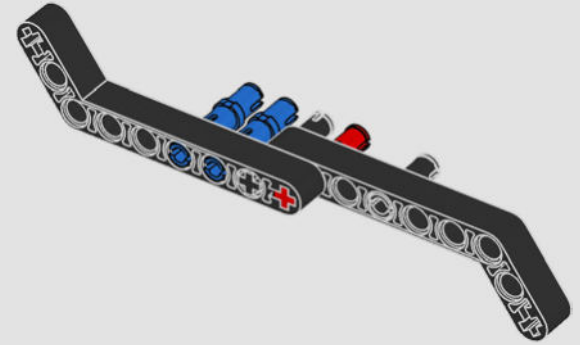

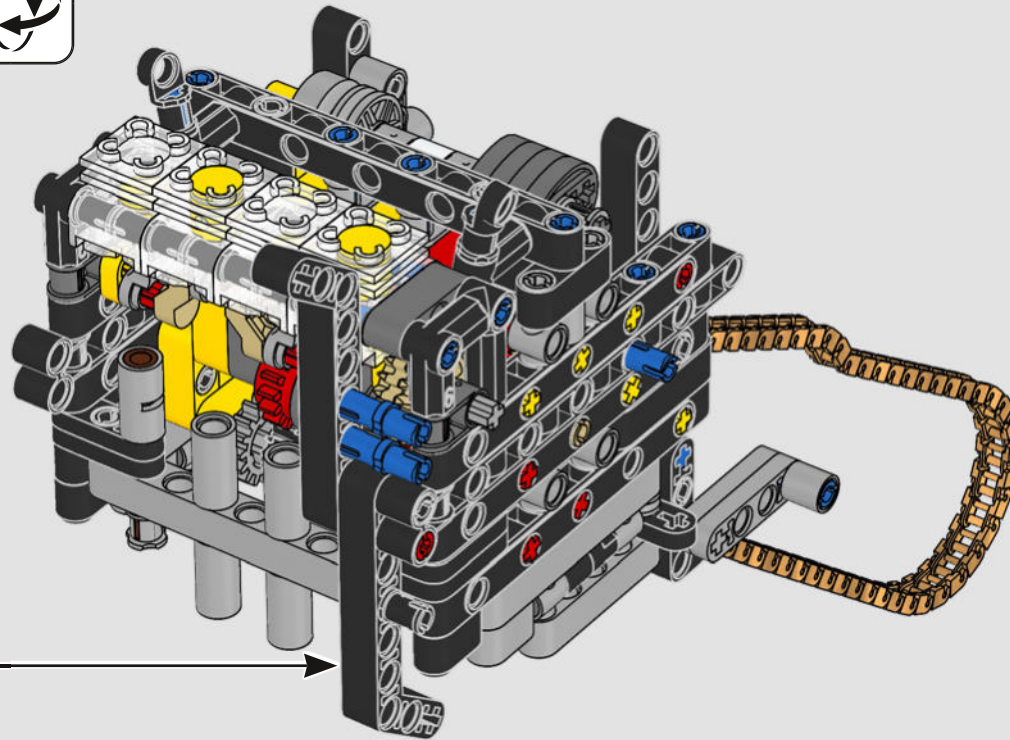

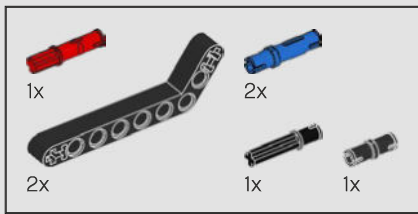

111

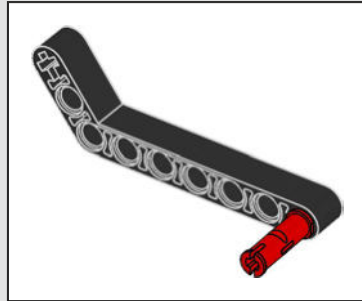

1

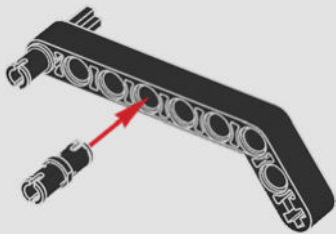

2

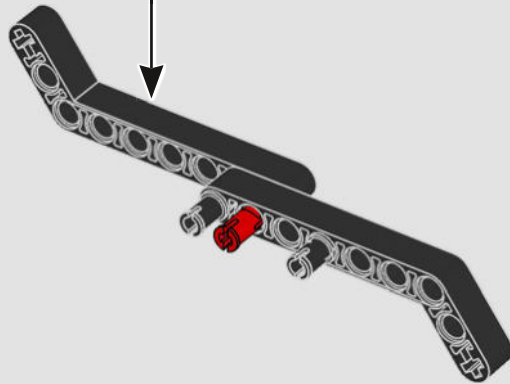

3

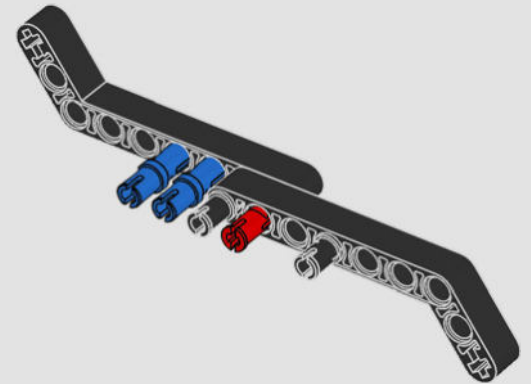

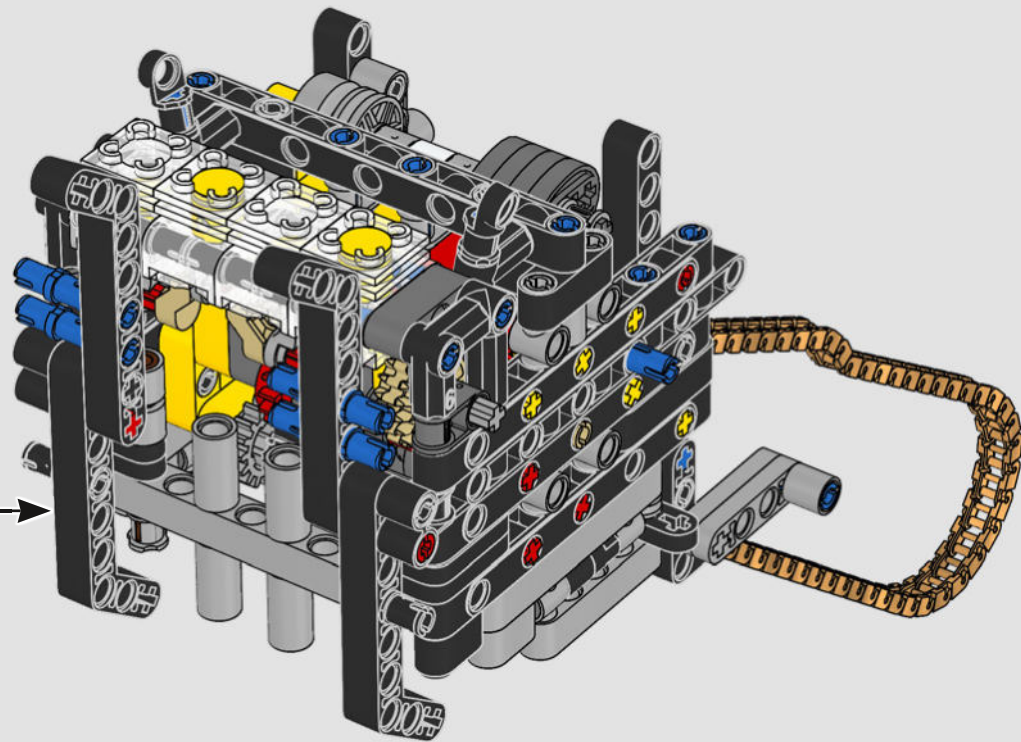

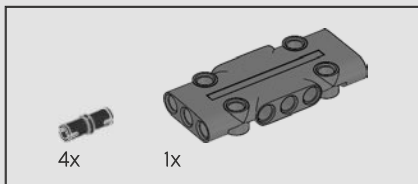

112

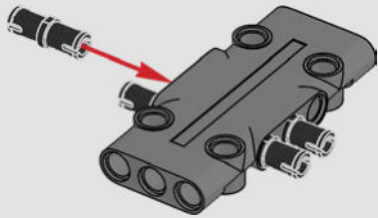

113

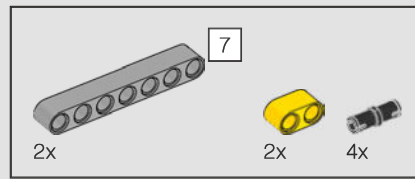
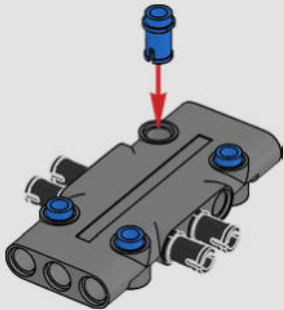

114

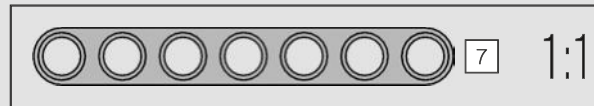
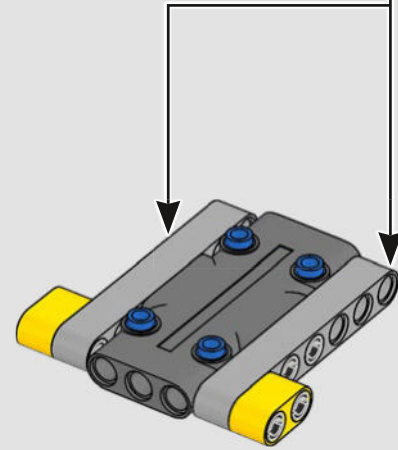
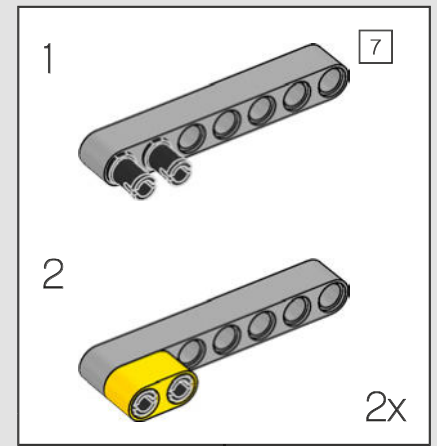

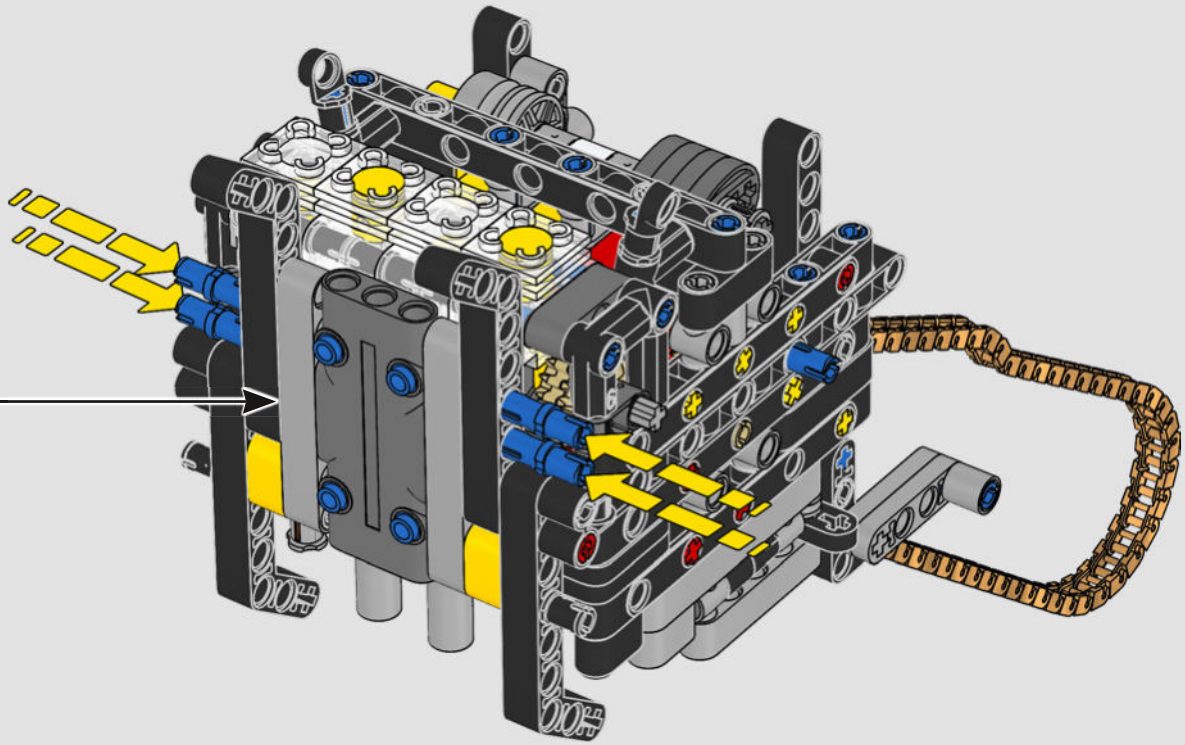

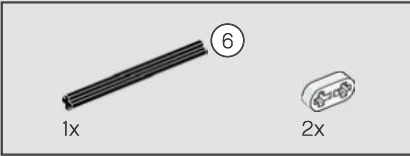
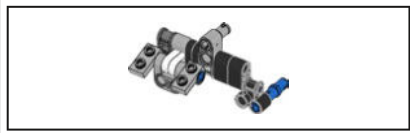

116

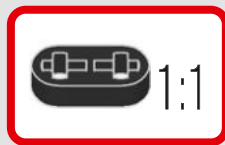
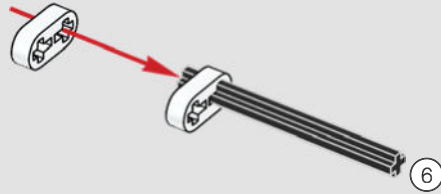

117

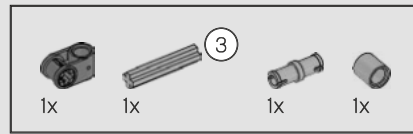
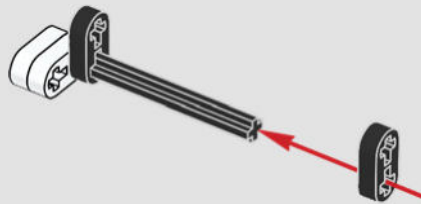

118

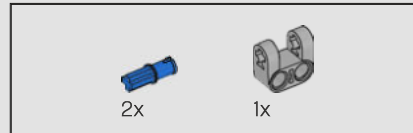
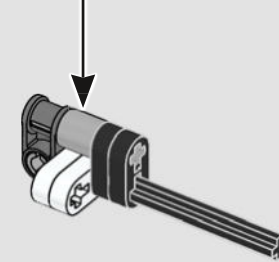
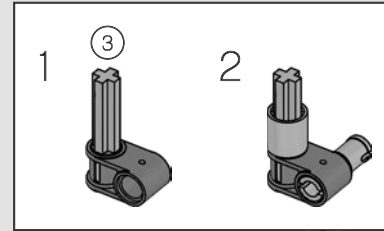

119

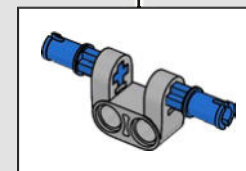
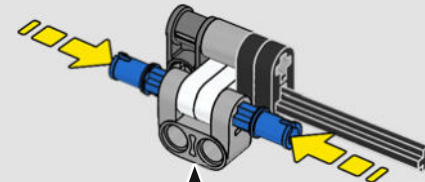



2x

120

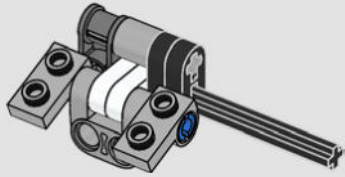

1x



1x

121

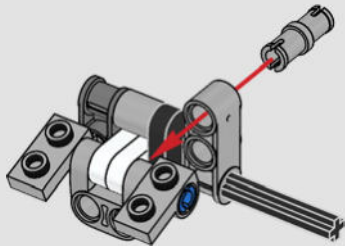

2x

122

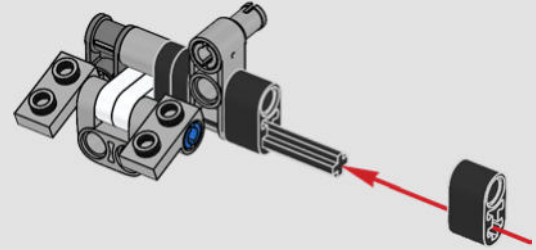

1:1



1x



1x

123

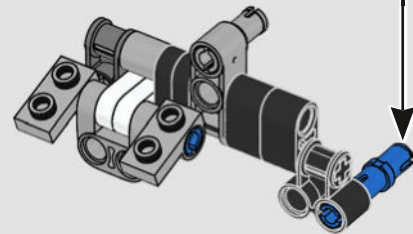

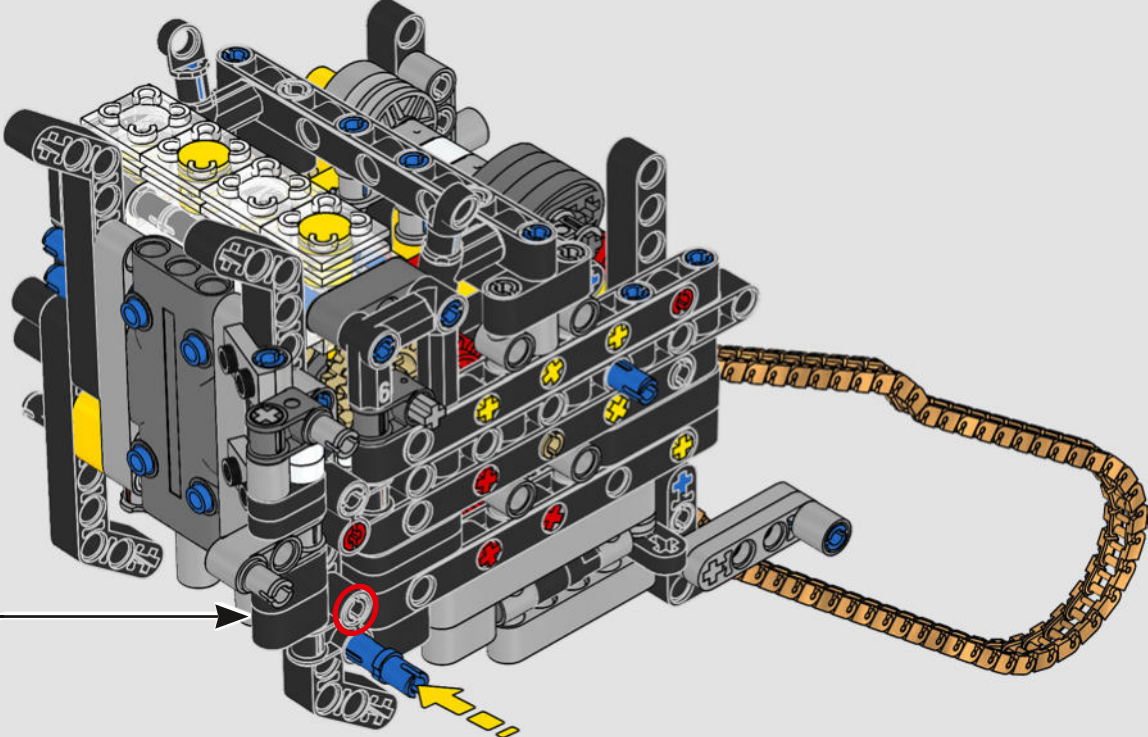

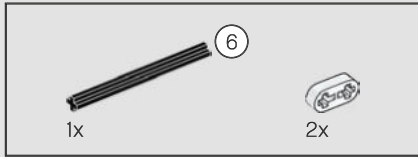

125

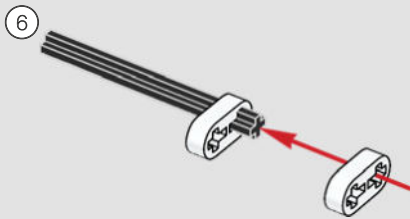

126

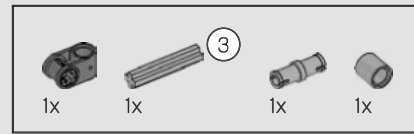
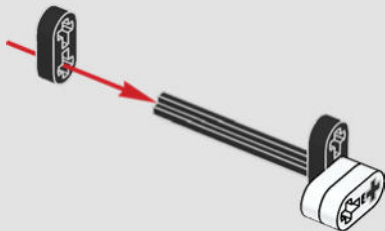
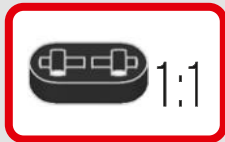

127

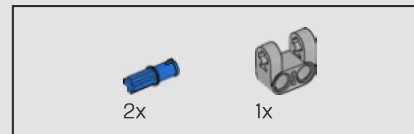
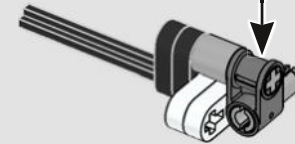
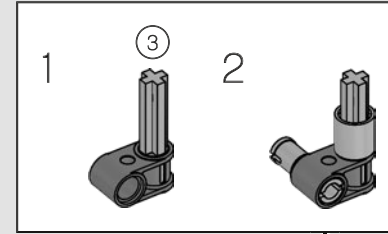

128

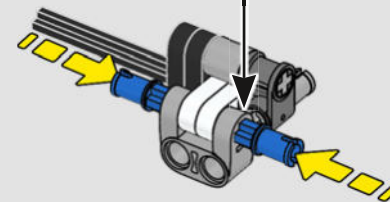
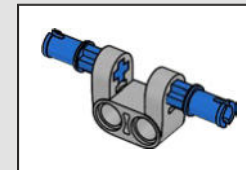



129

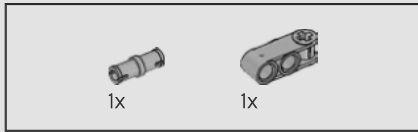
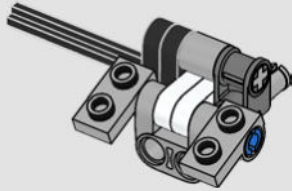

130

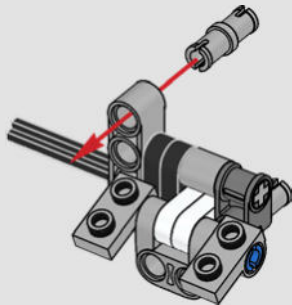

131

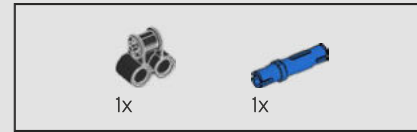
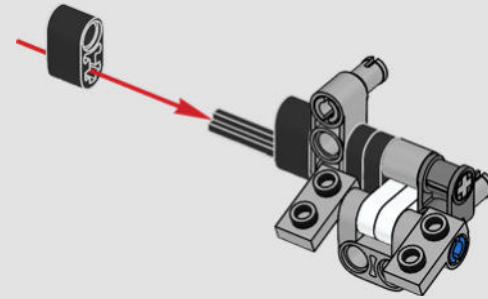

132

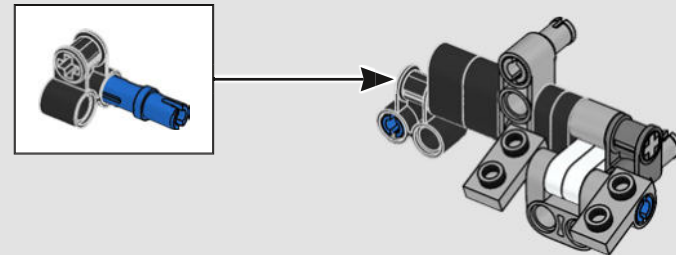

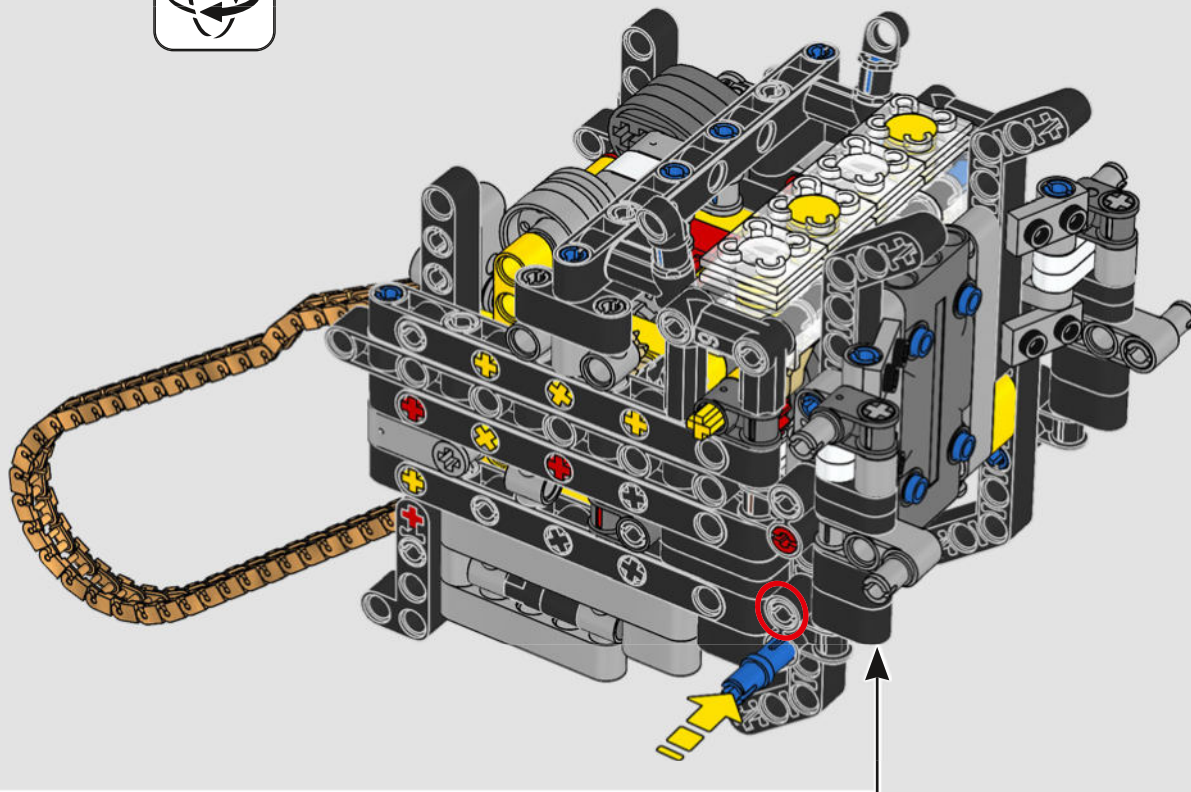

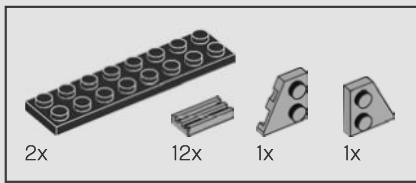

134

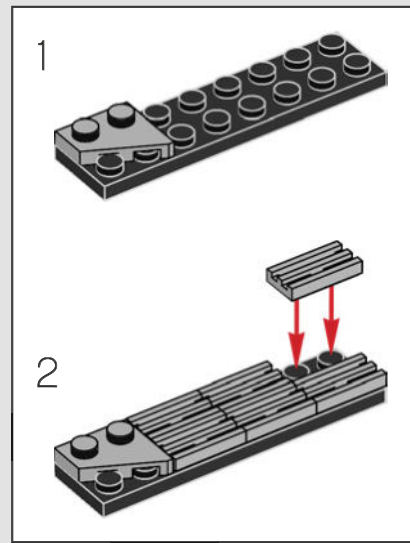
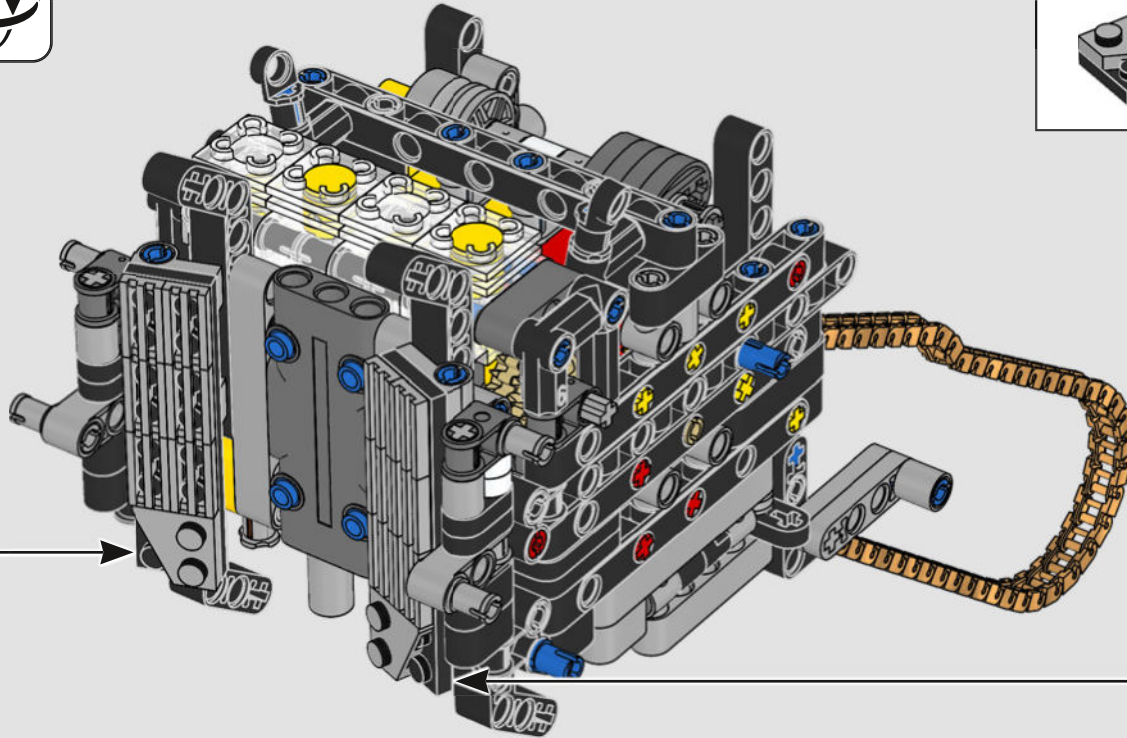
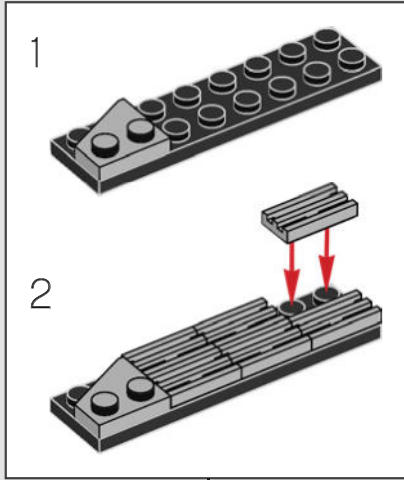

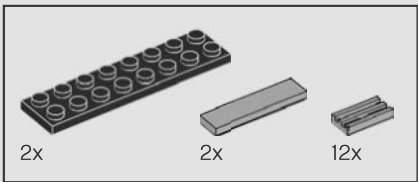

135

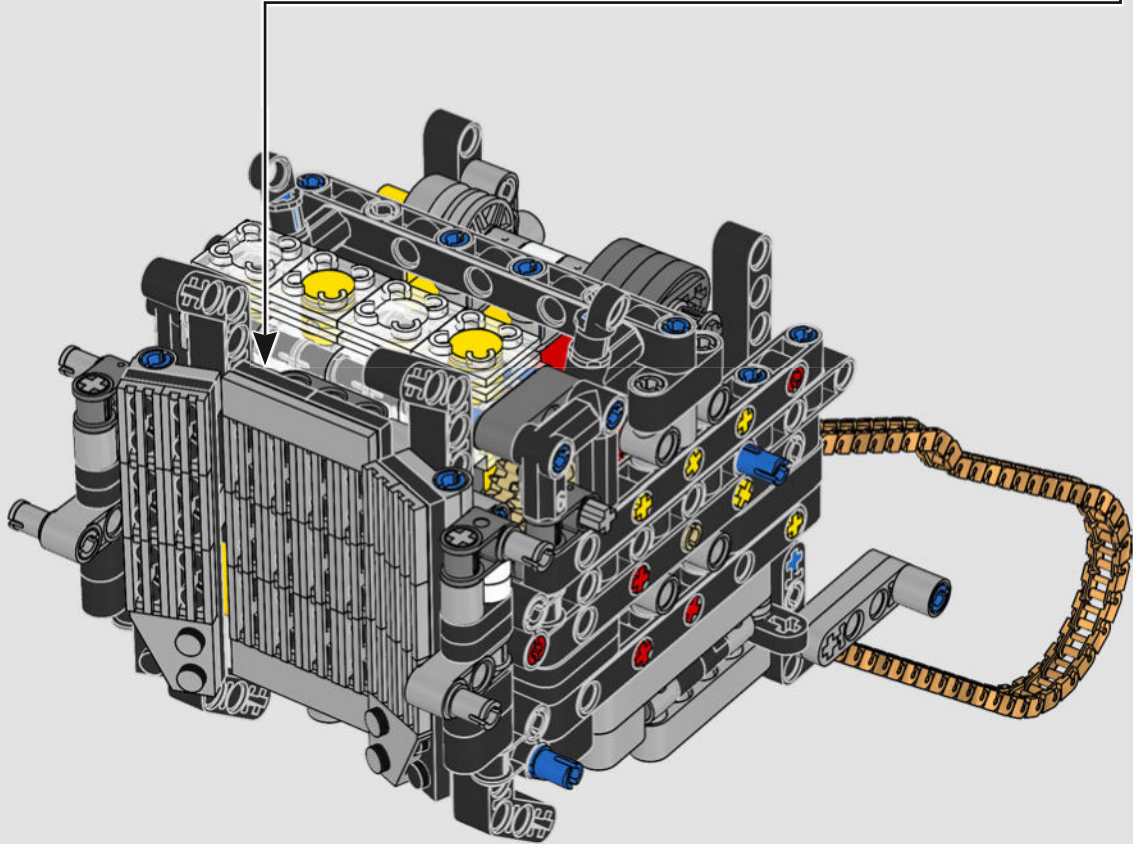
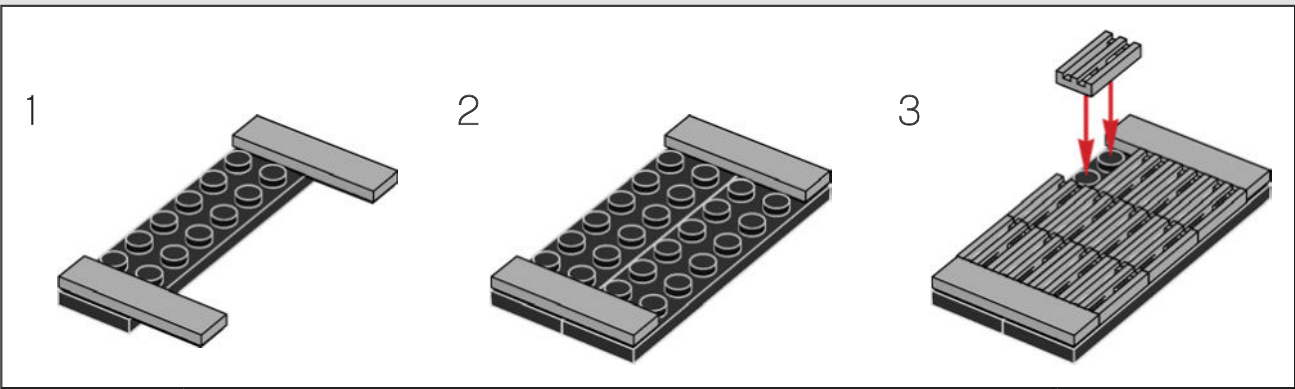

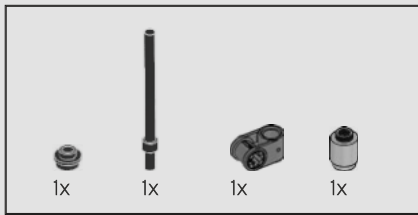

136

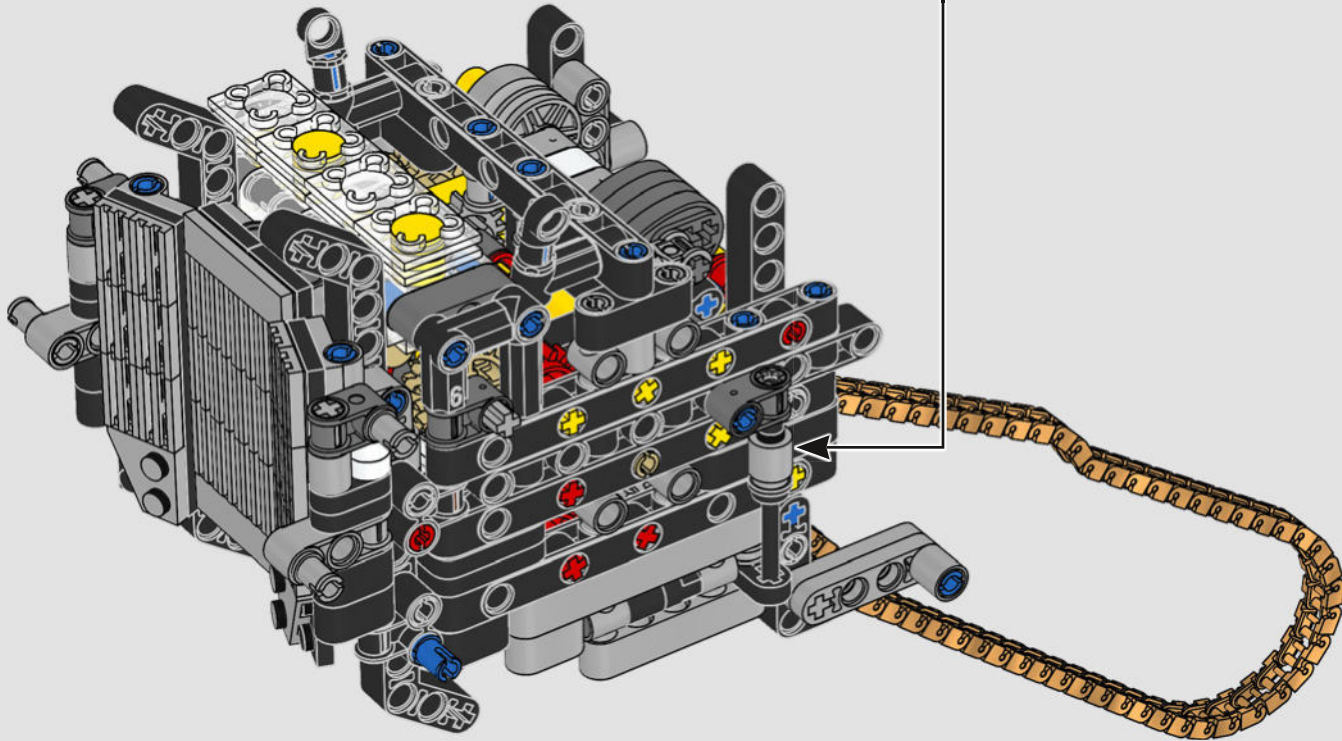
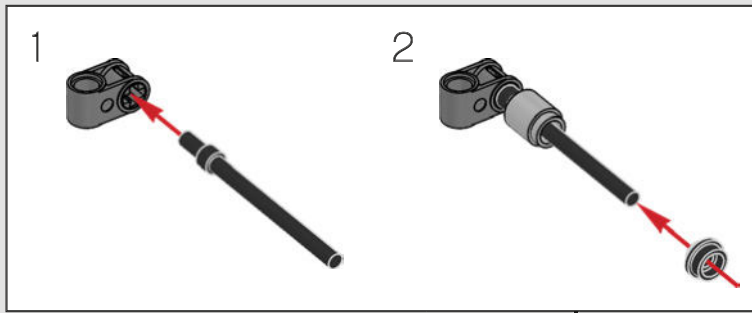

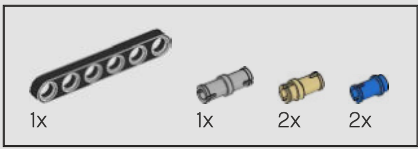

137

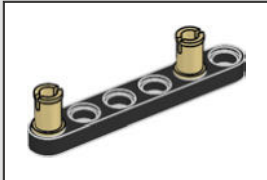
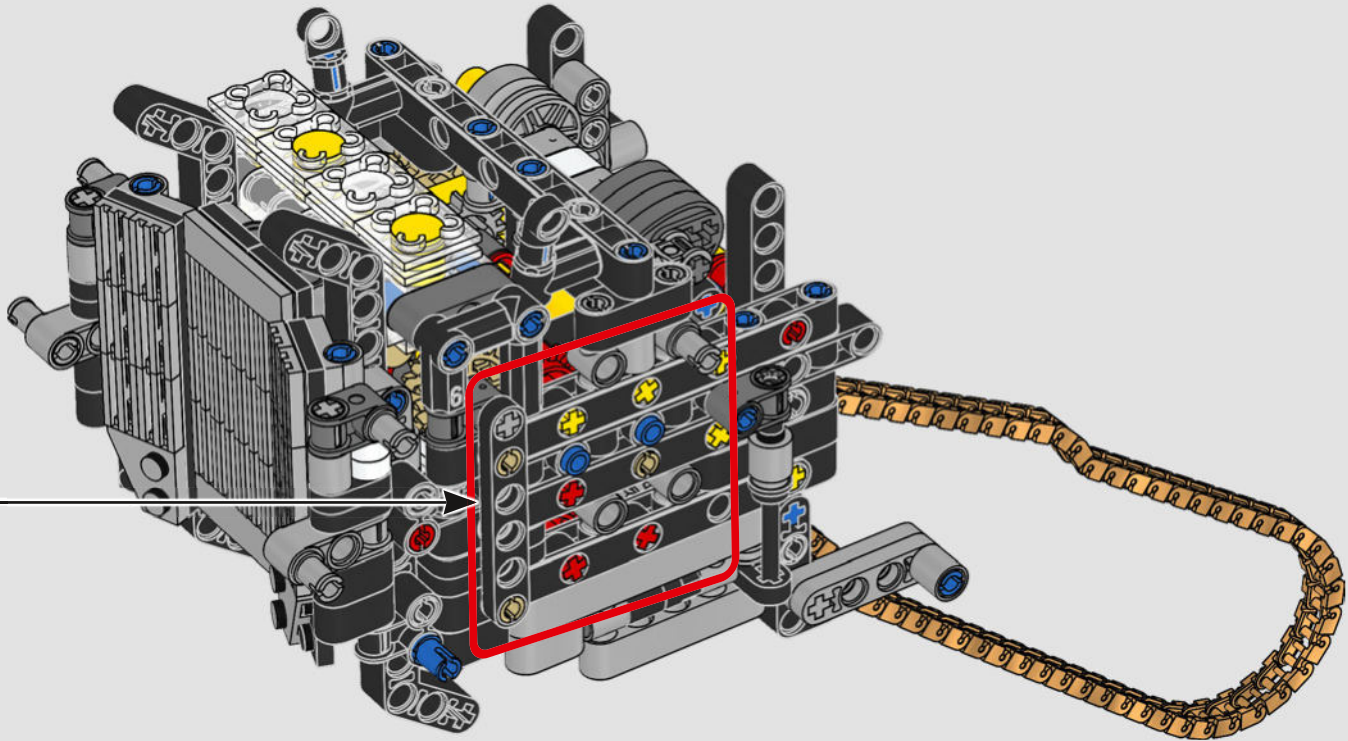

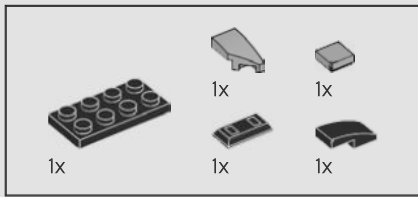

138

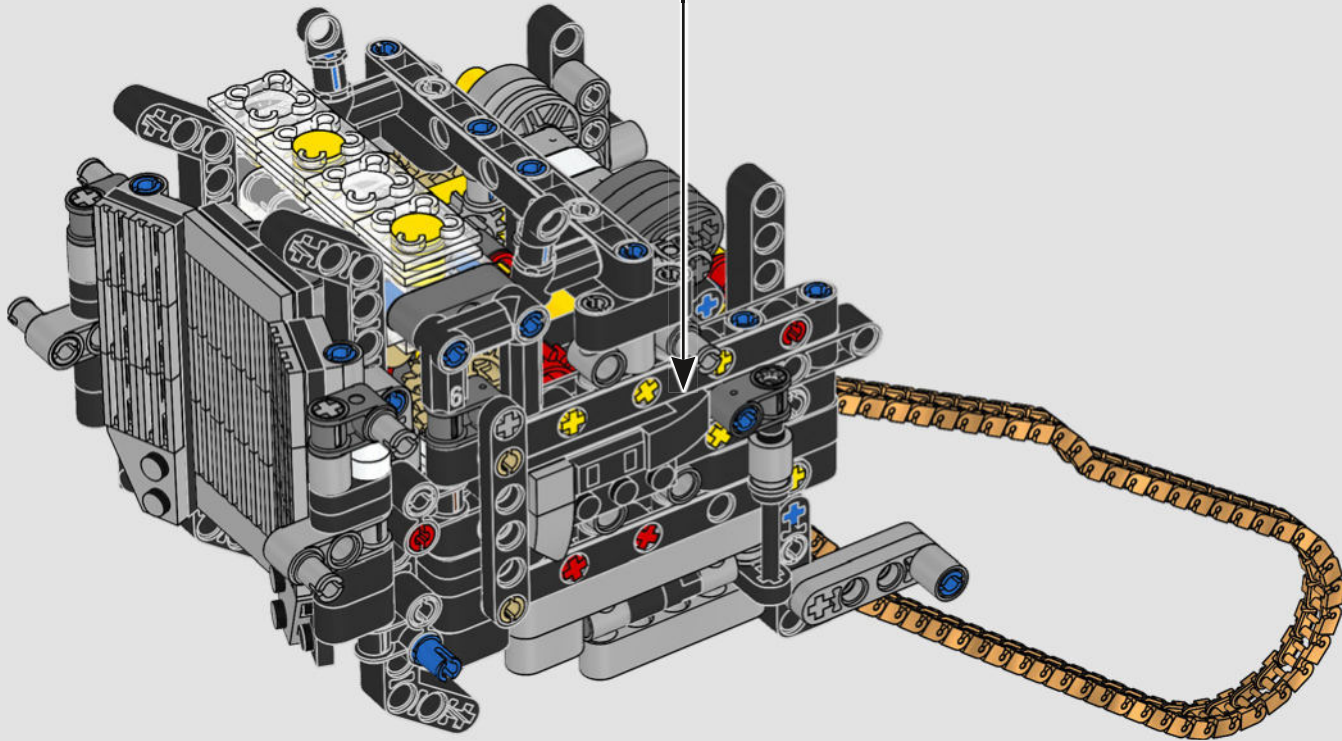
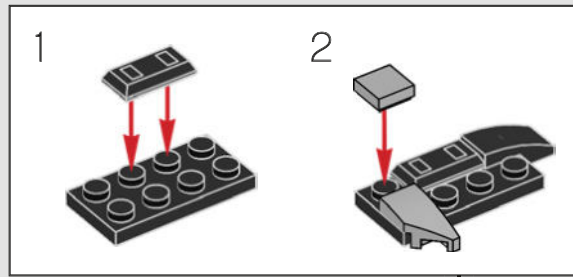

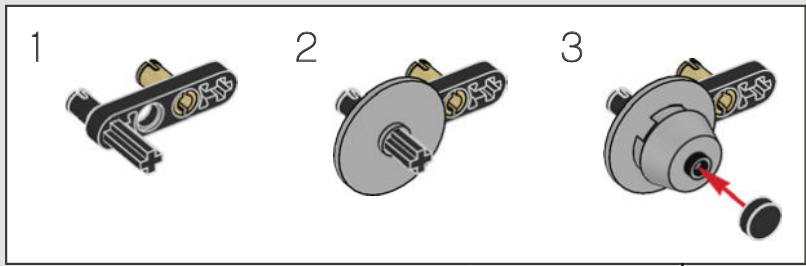
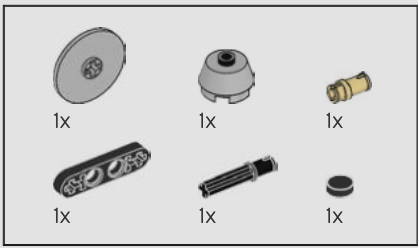

139

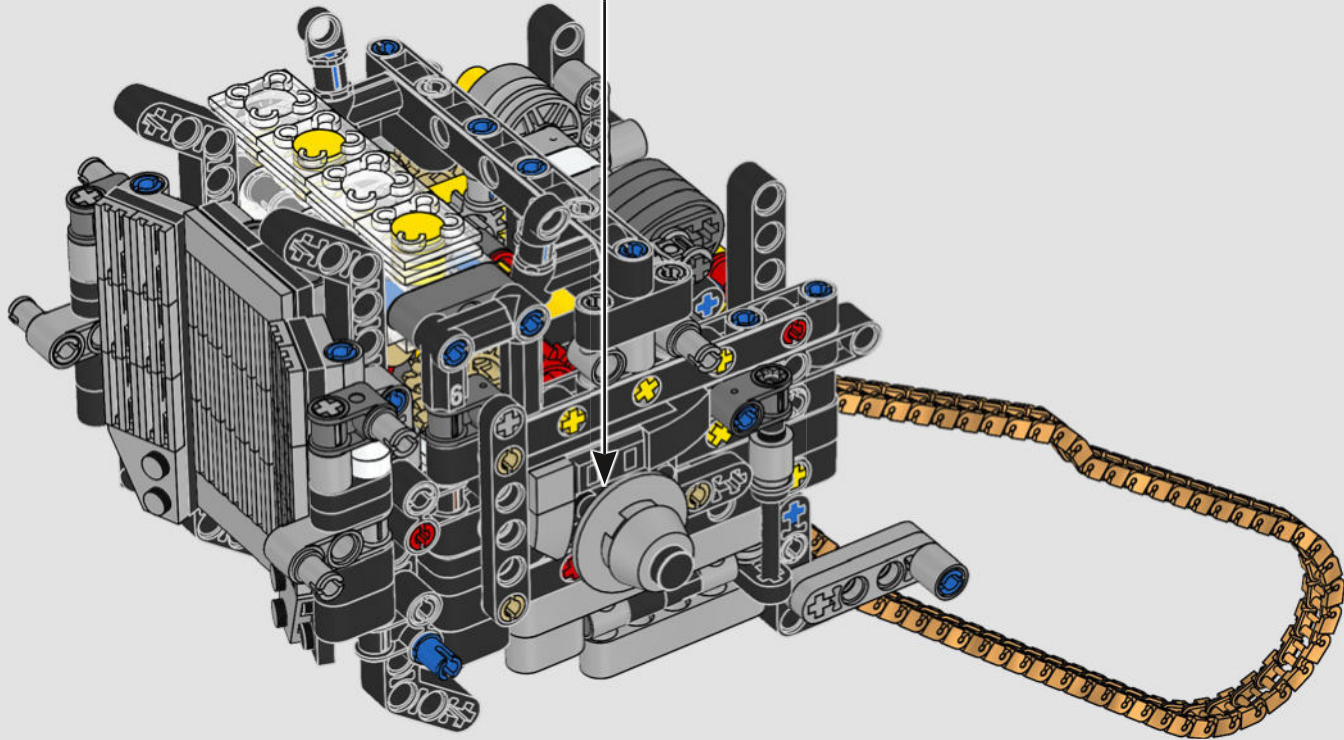

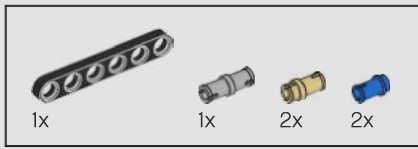

140

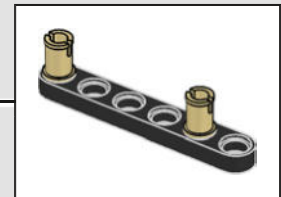
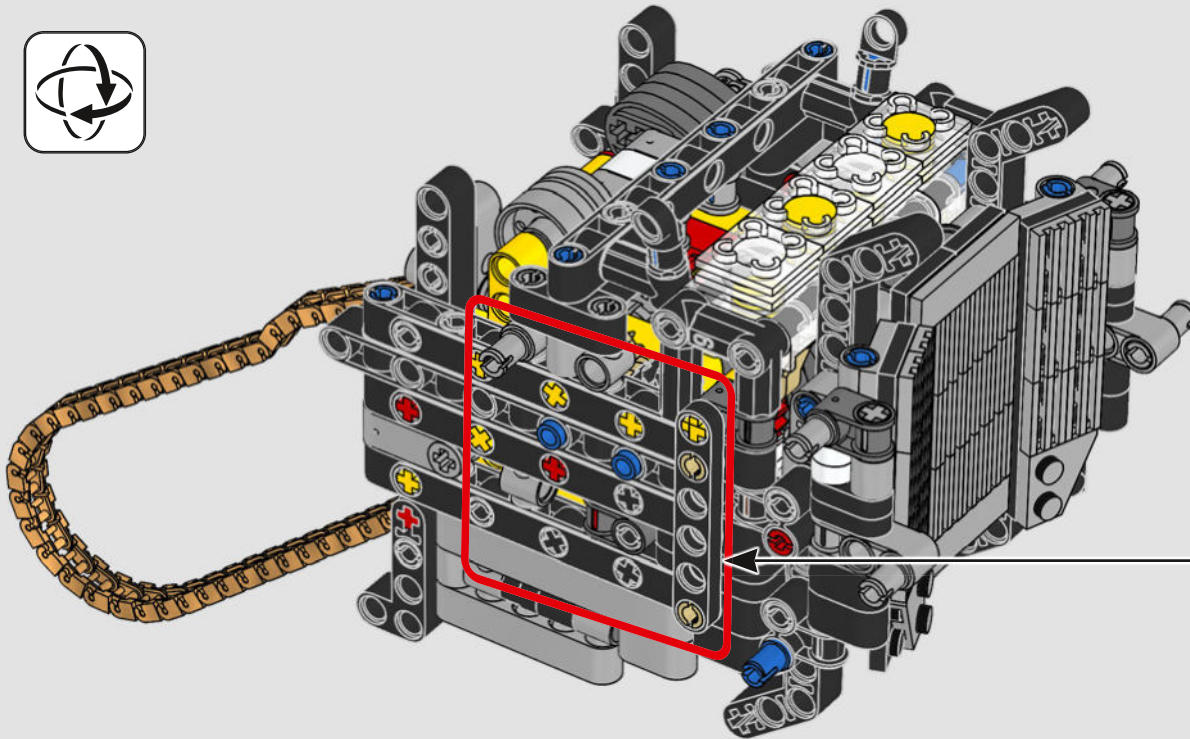

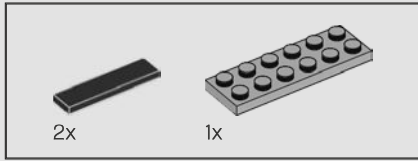

141

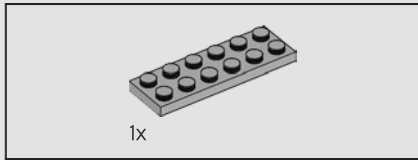
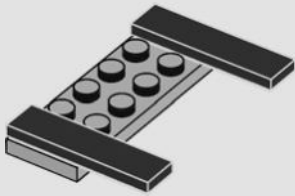

142

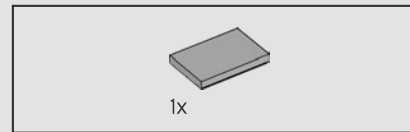
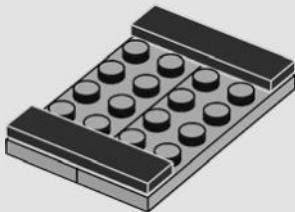

143

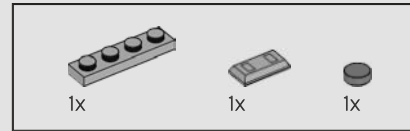
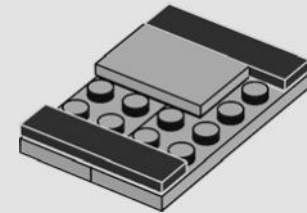

144

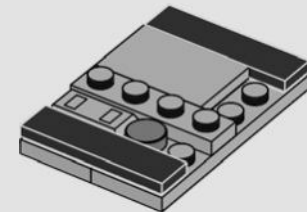

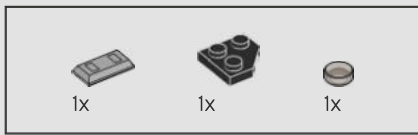

145

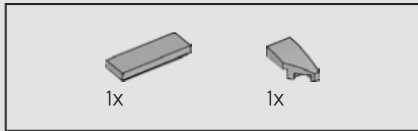
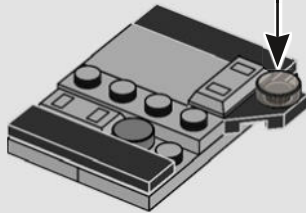
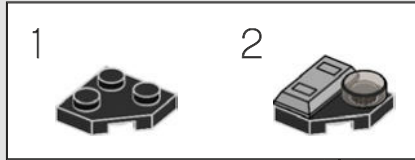

146

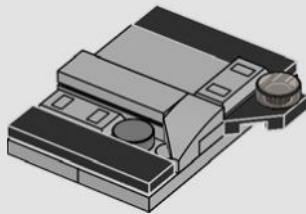

147

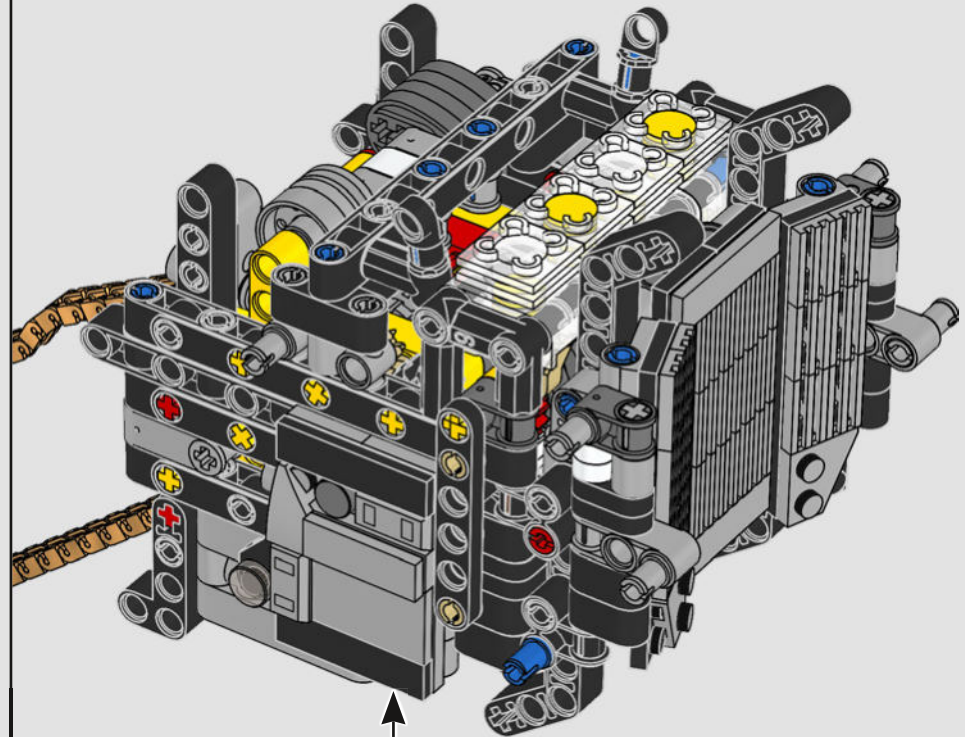

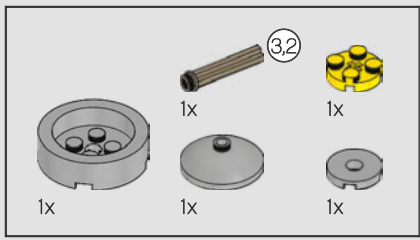

148

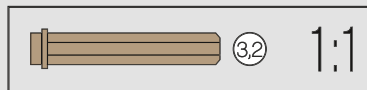
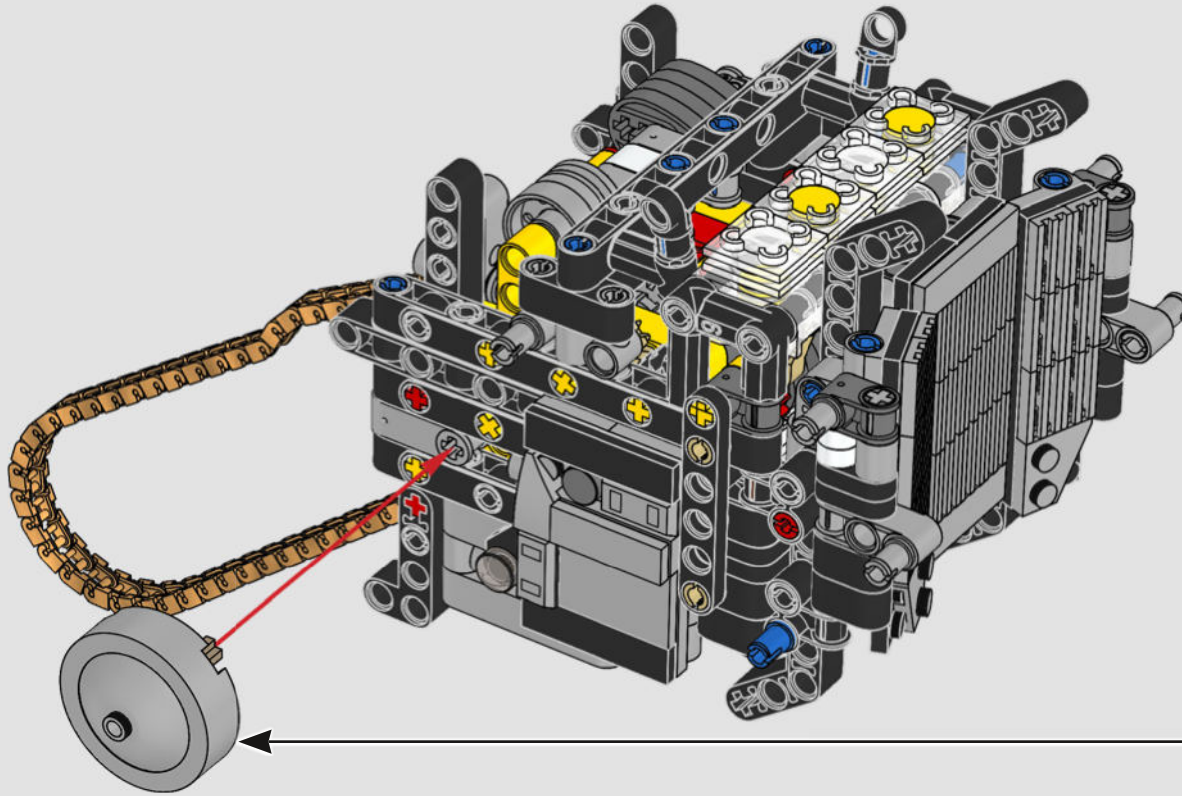
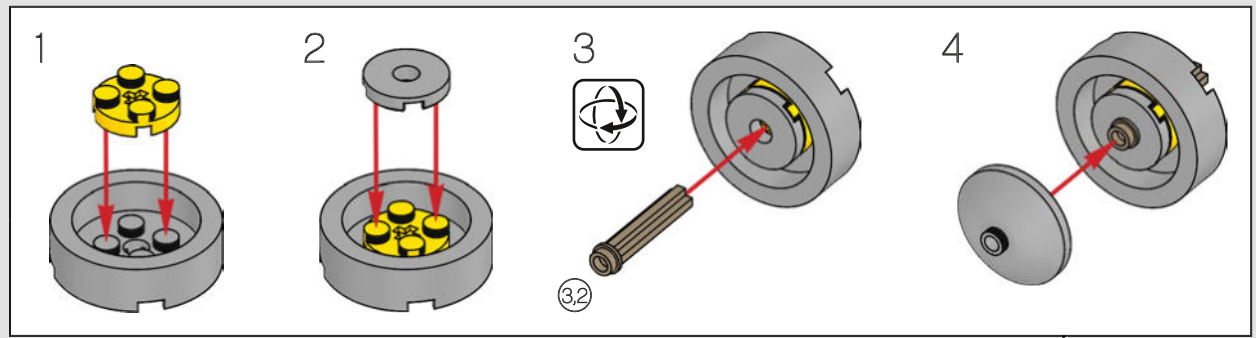

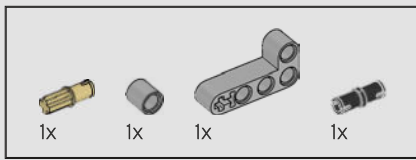

149

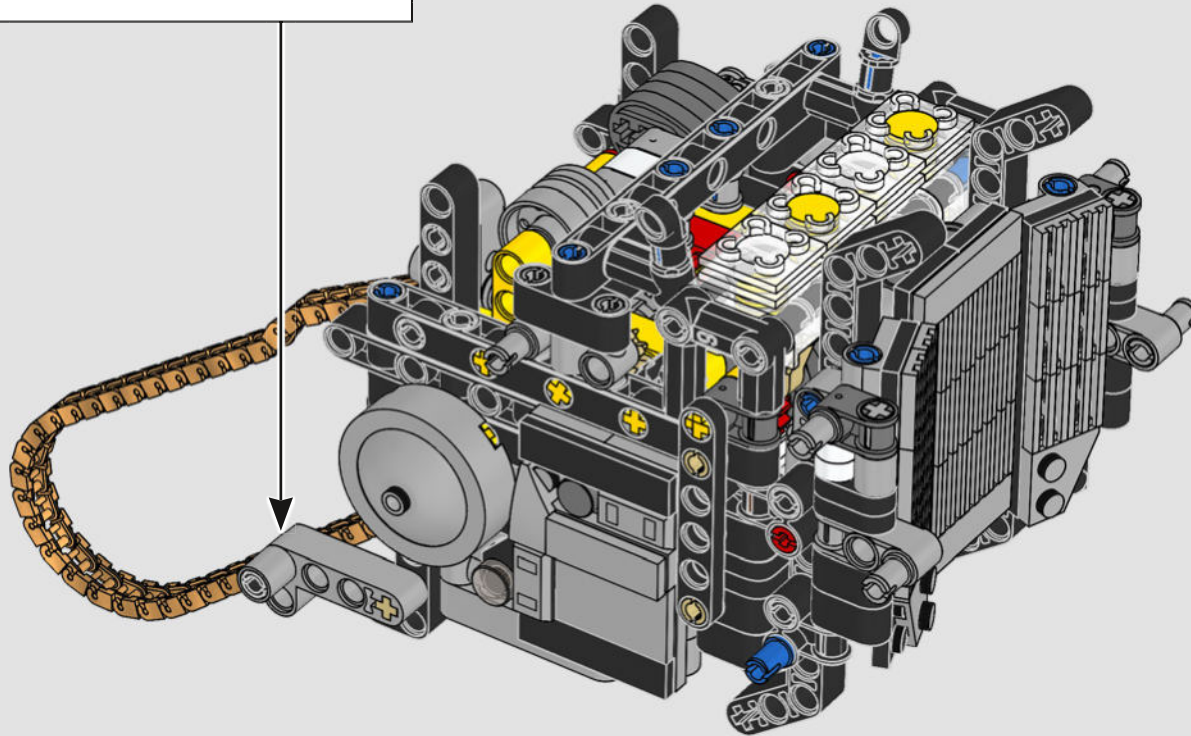
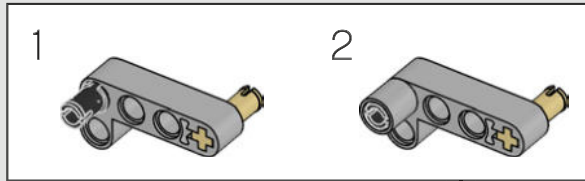

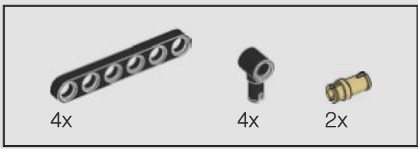

150

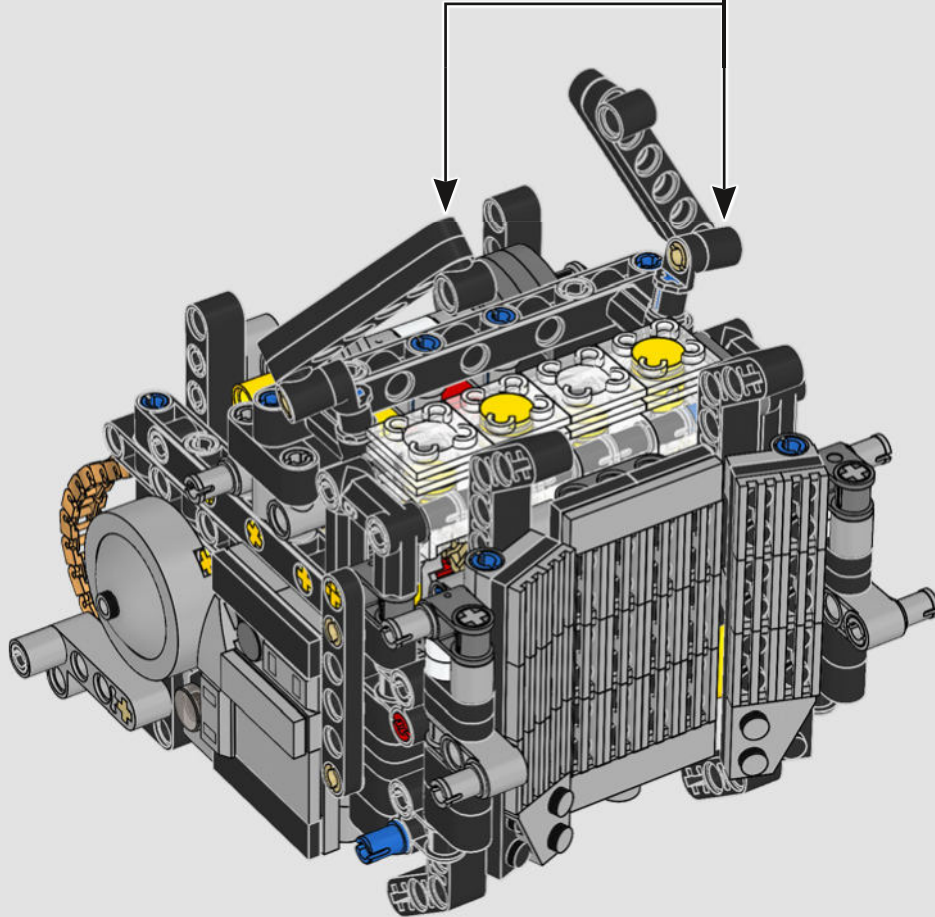
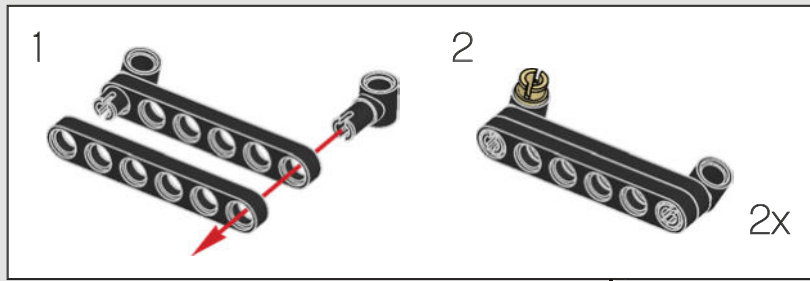

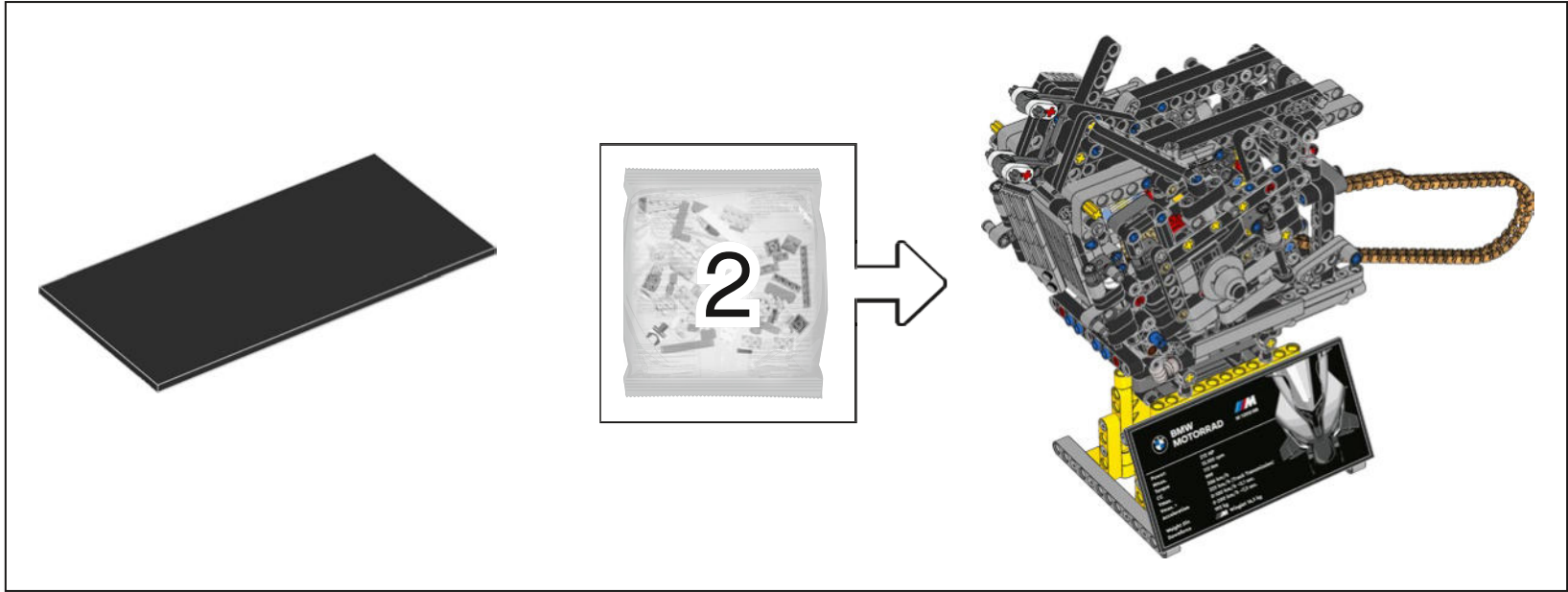

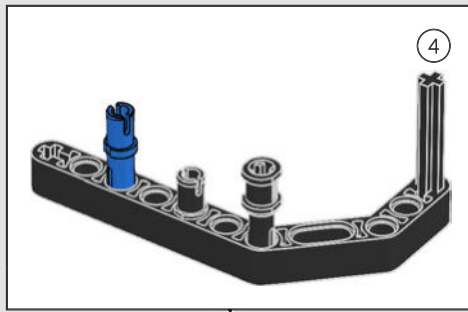
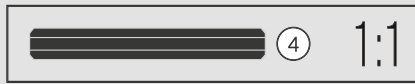
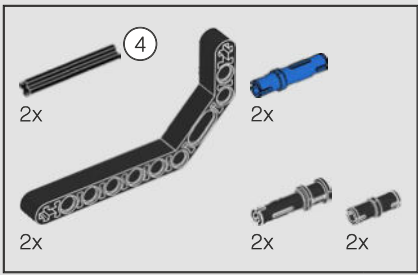

151

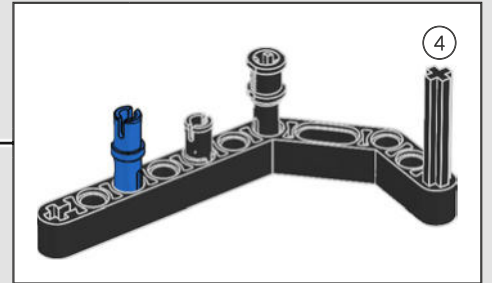
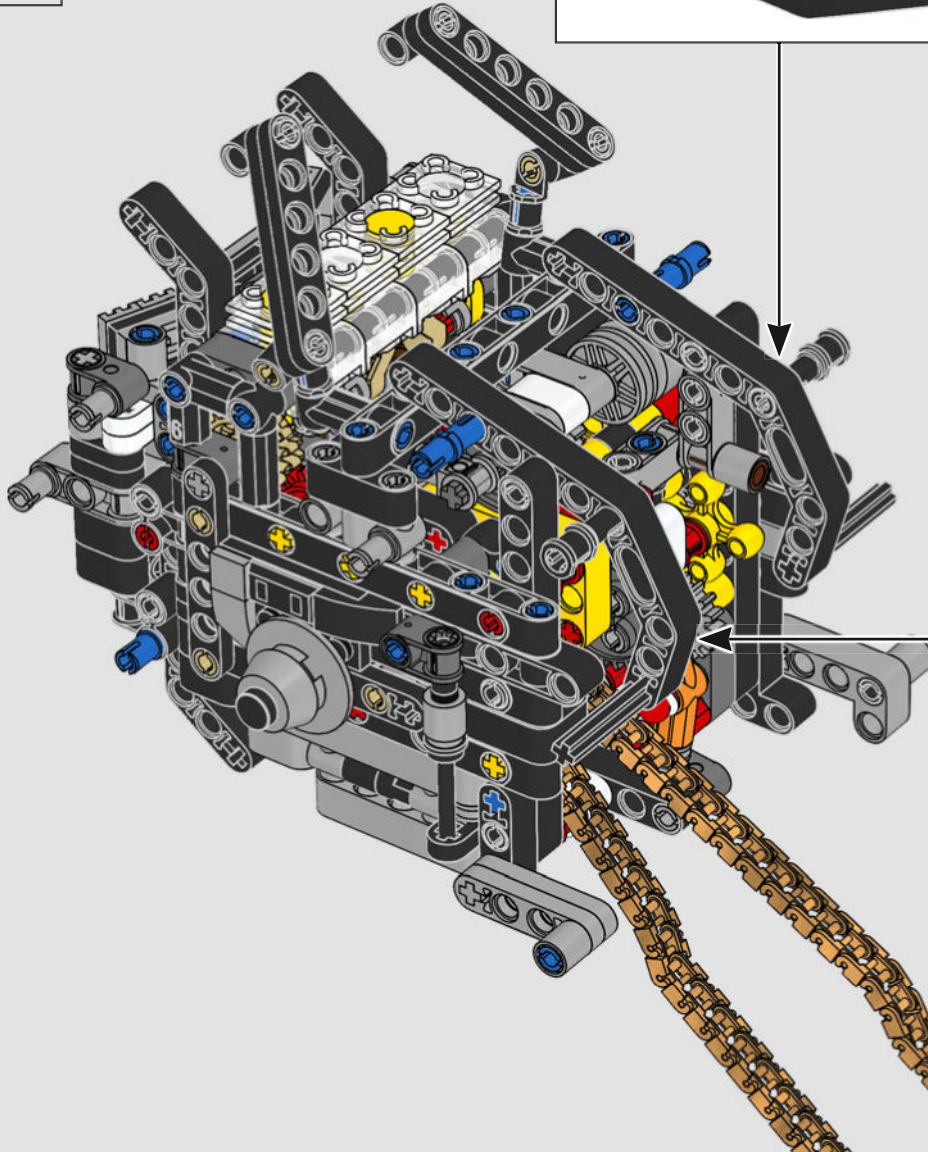

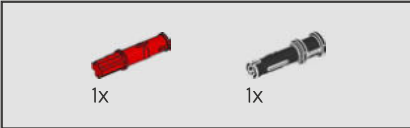
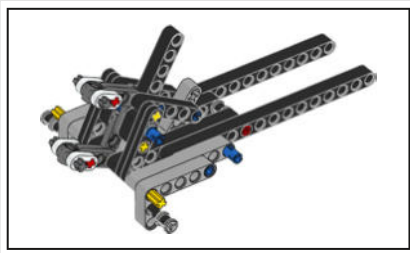

152

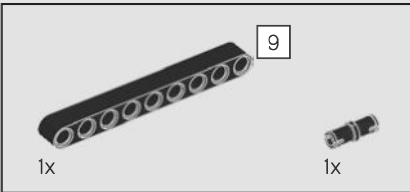

153

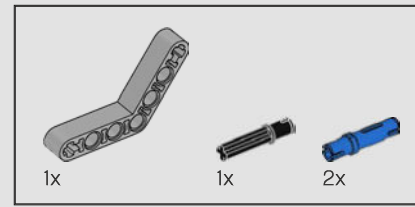
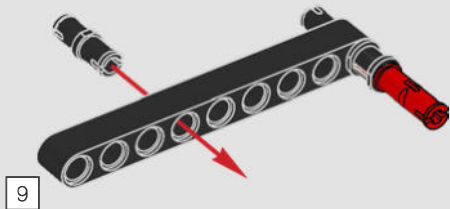

154

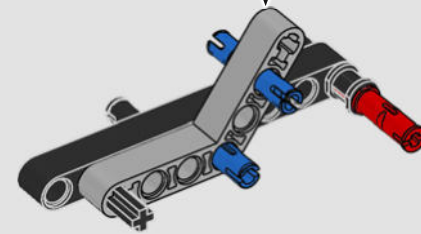
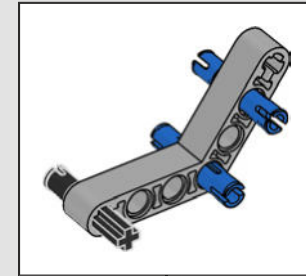

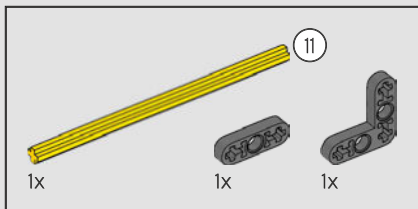

155

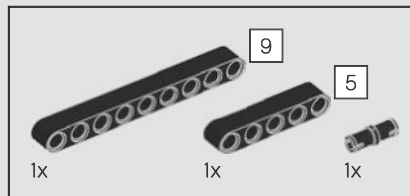
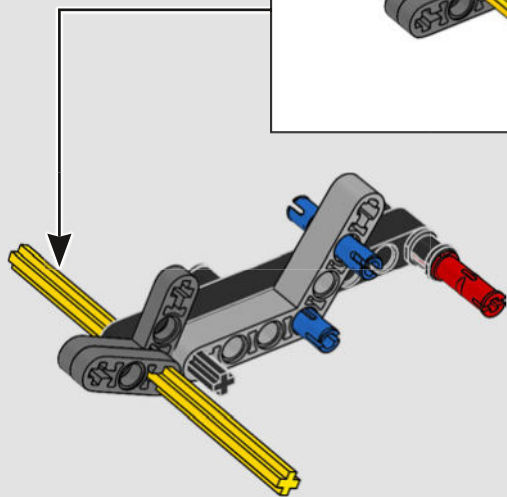
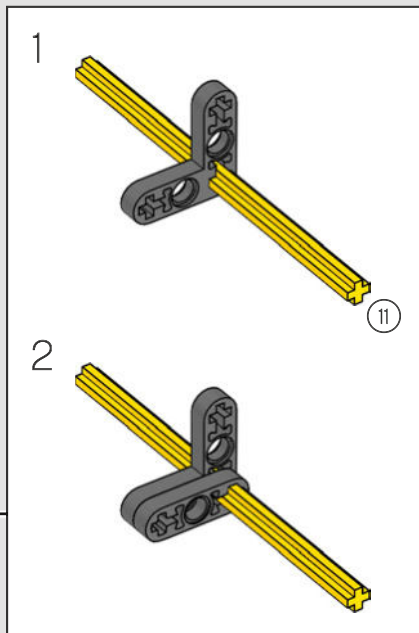

156

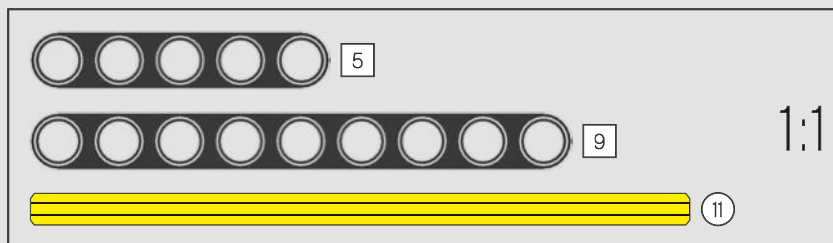
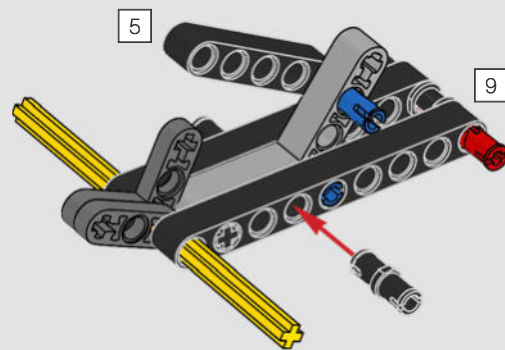

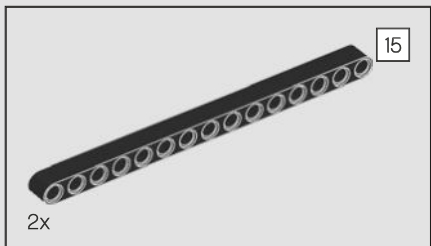

157

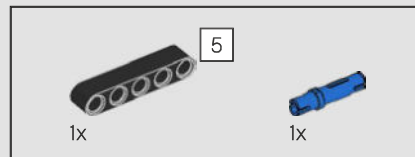
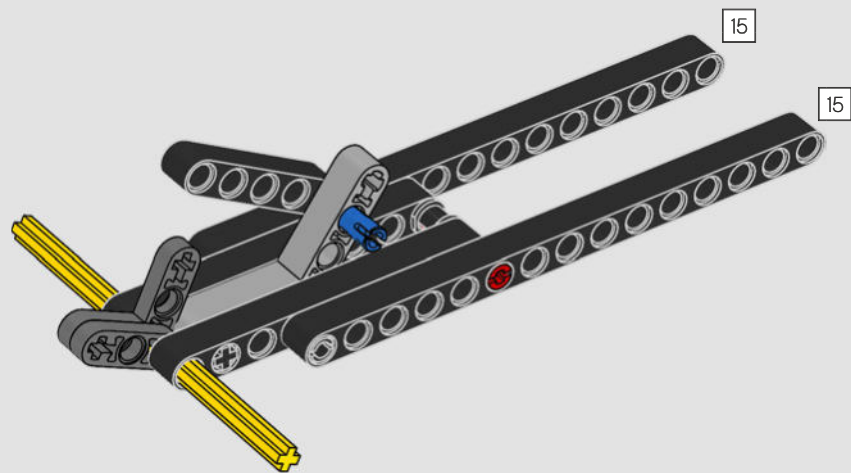

158

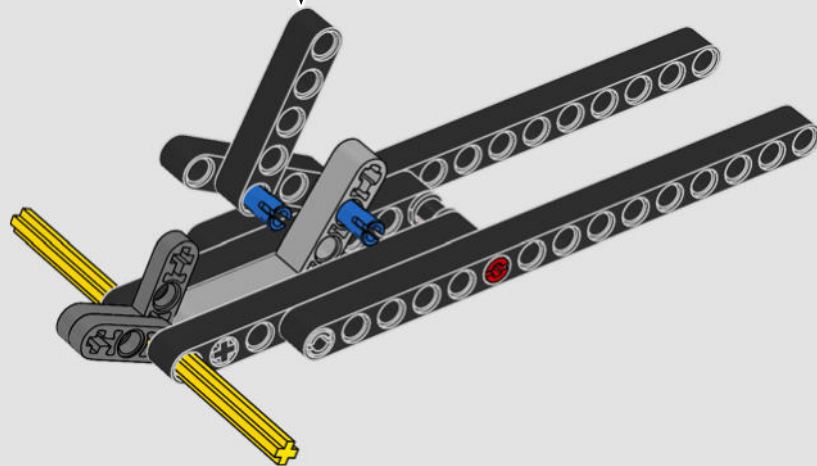
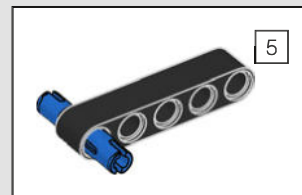

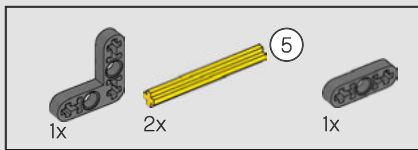

159

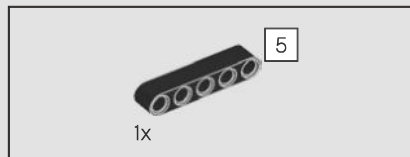
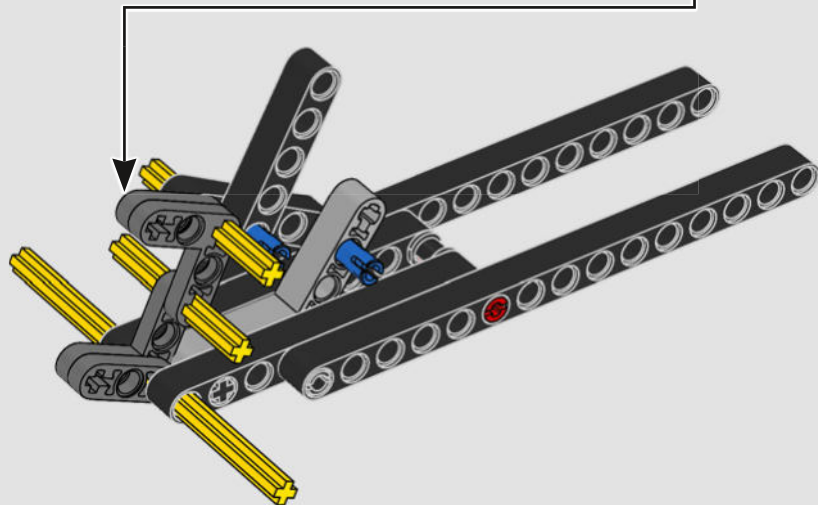
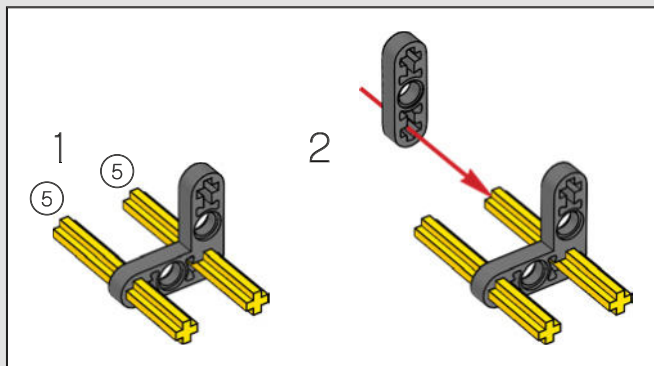

160

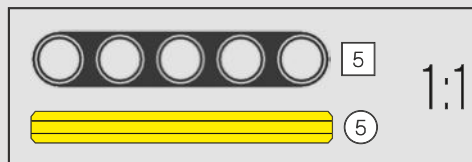
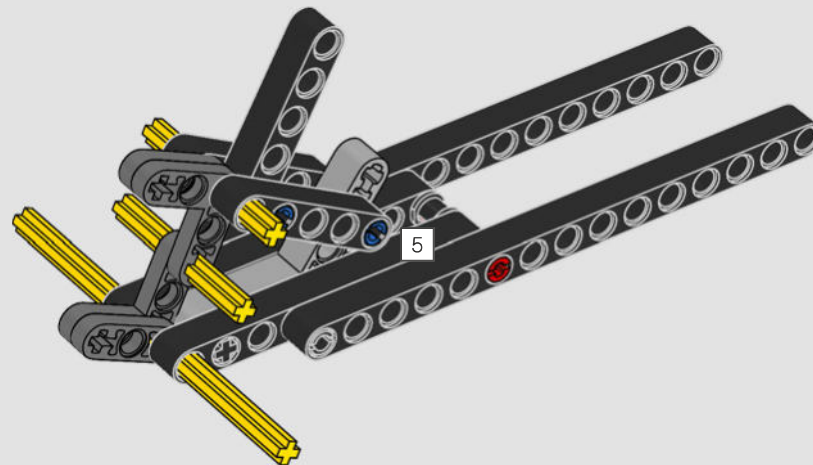



161

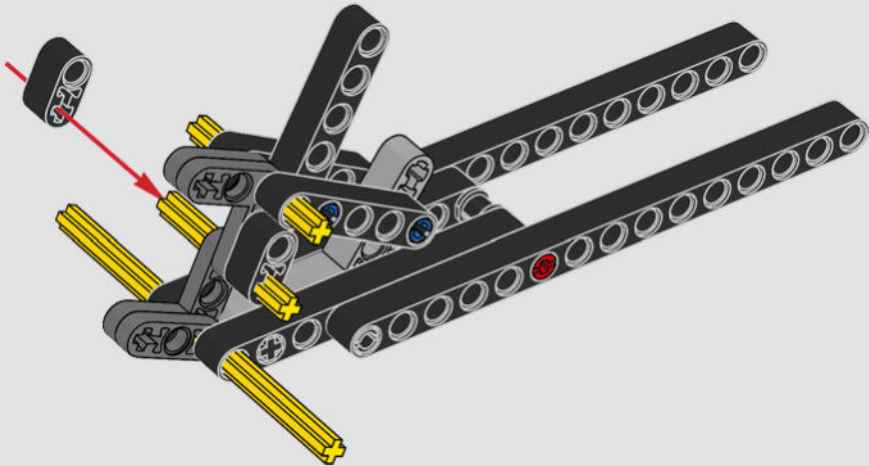

162

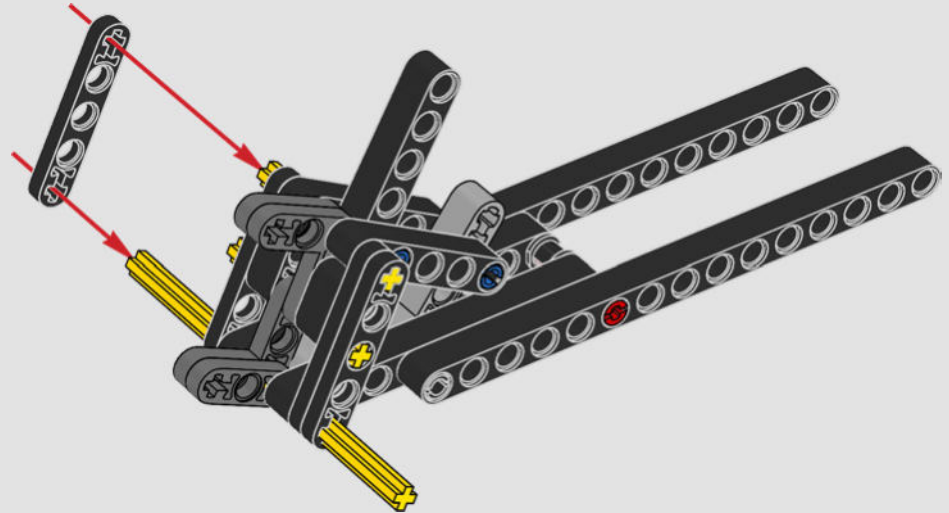

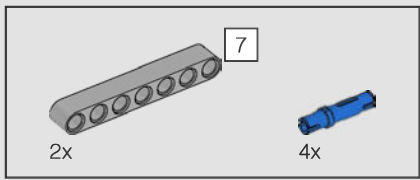

163

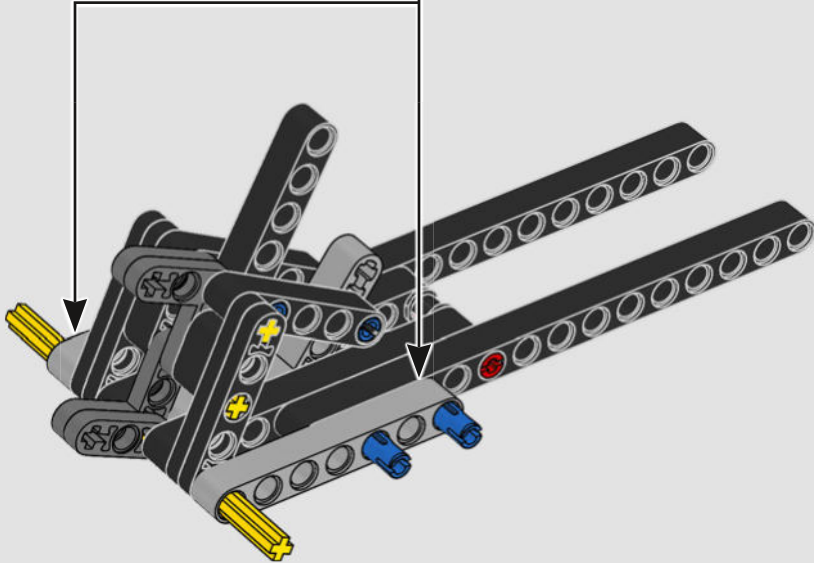
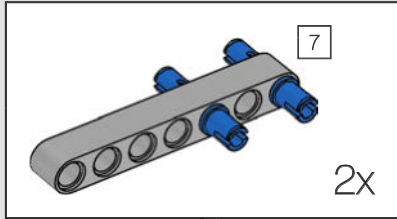

164

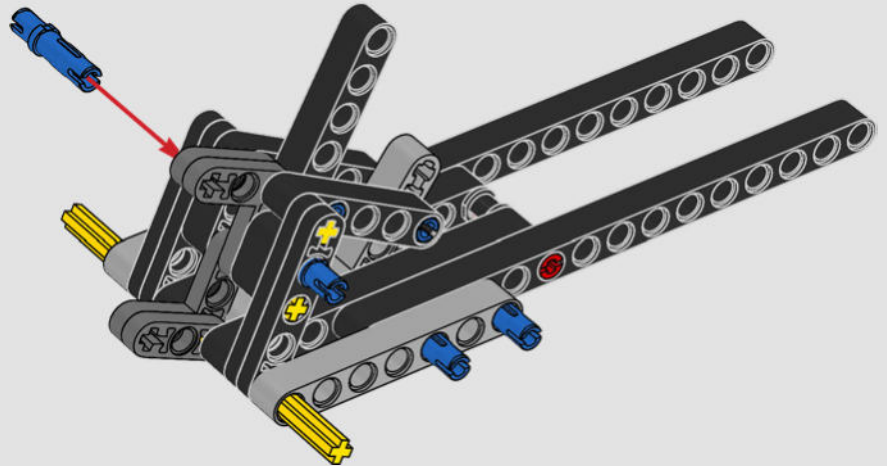

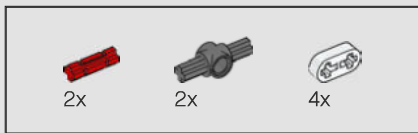

165

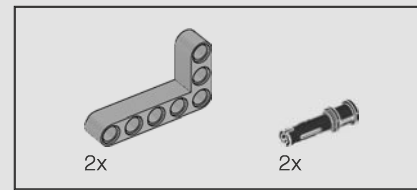
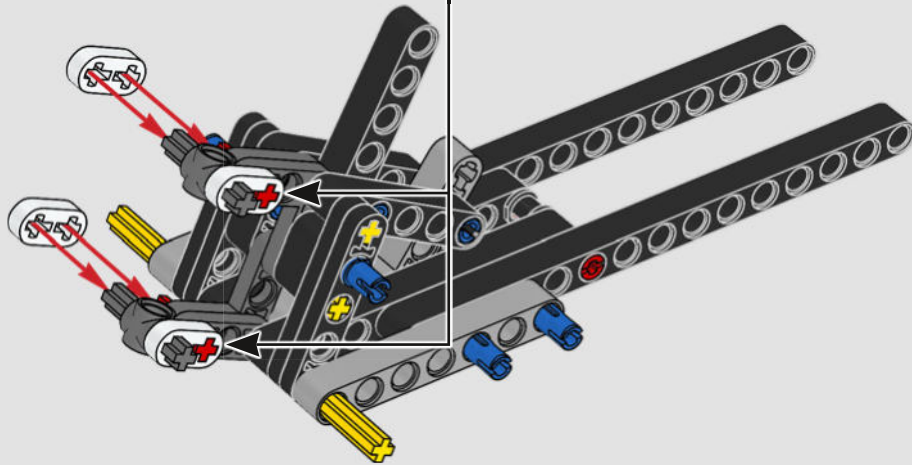

166

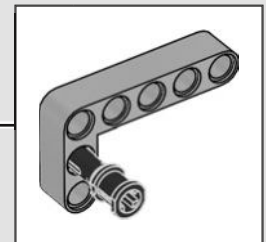
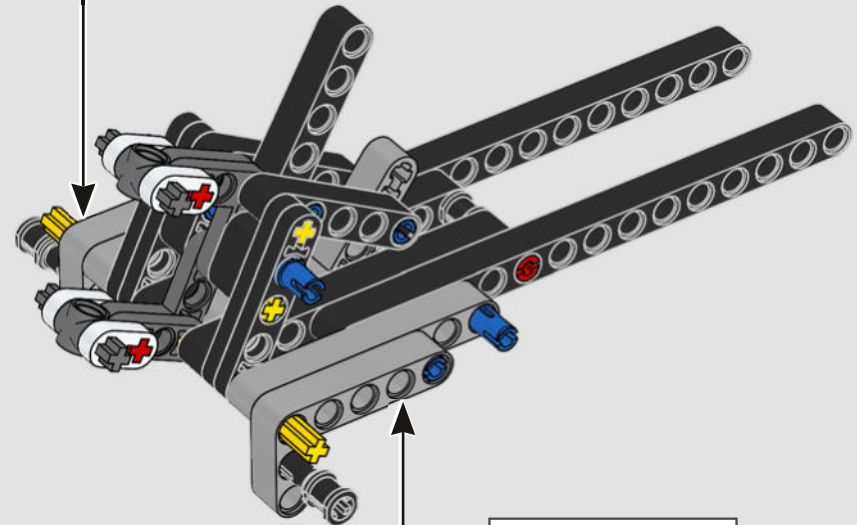
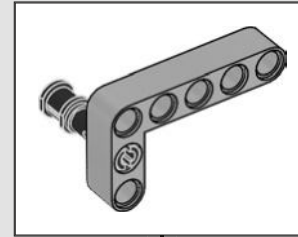

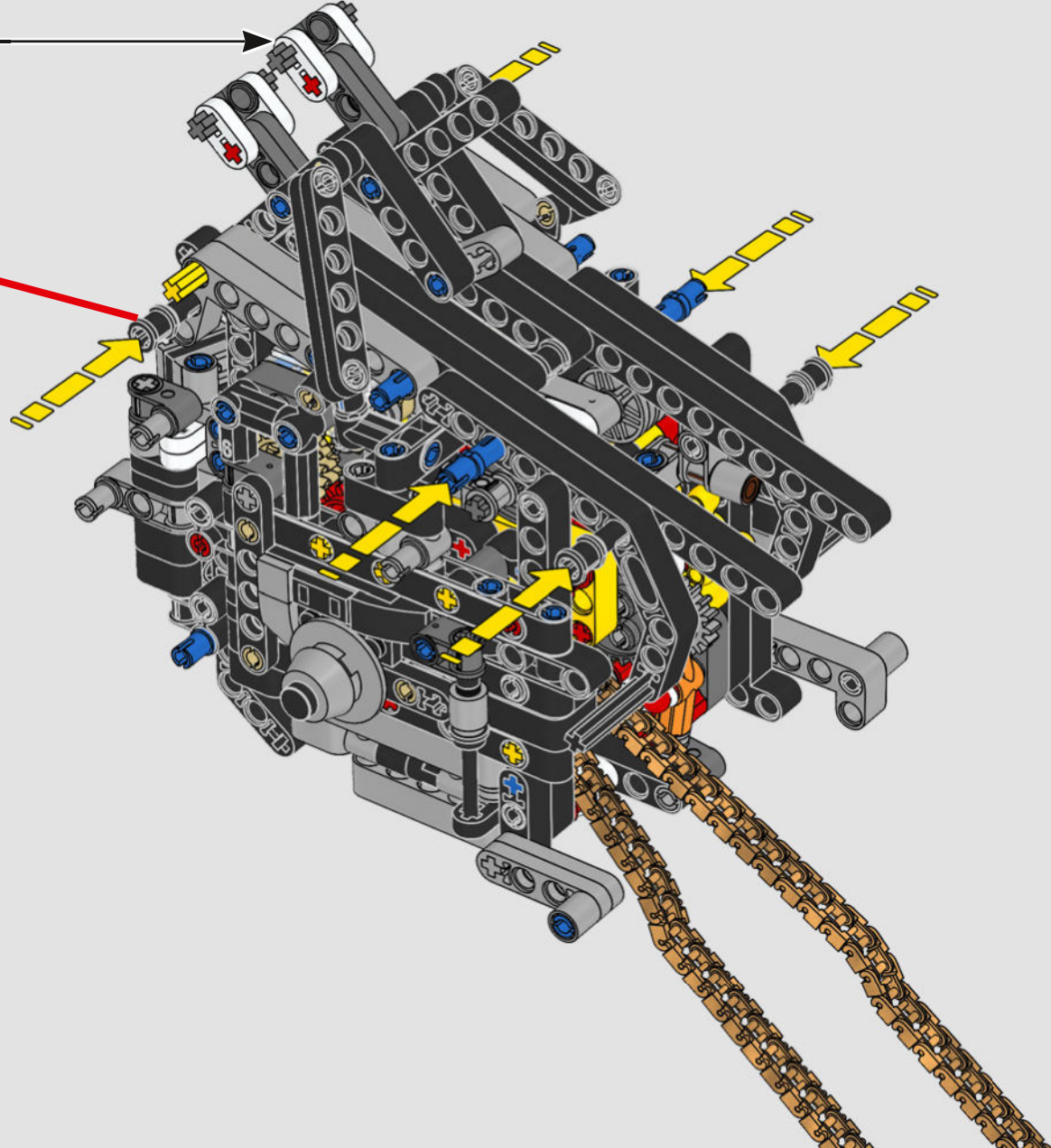
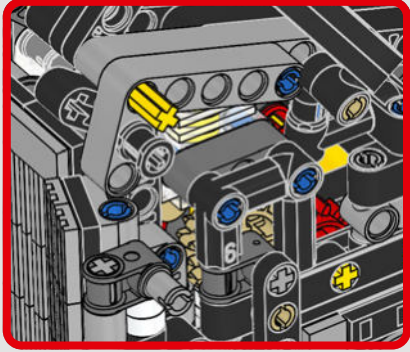

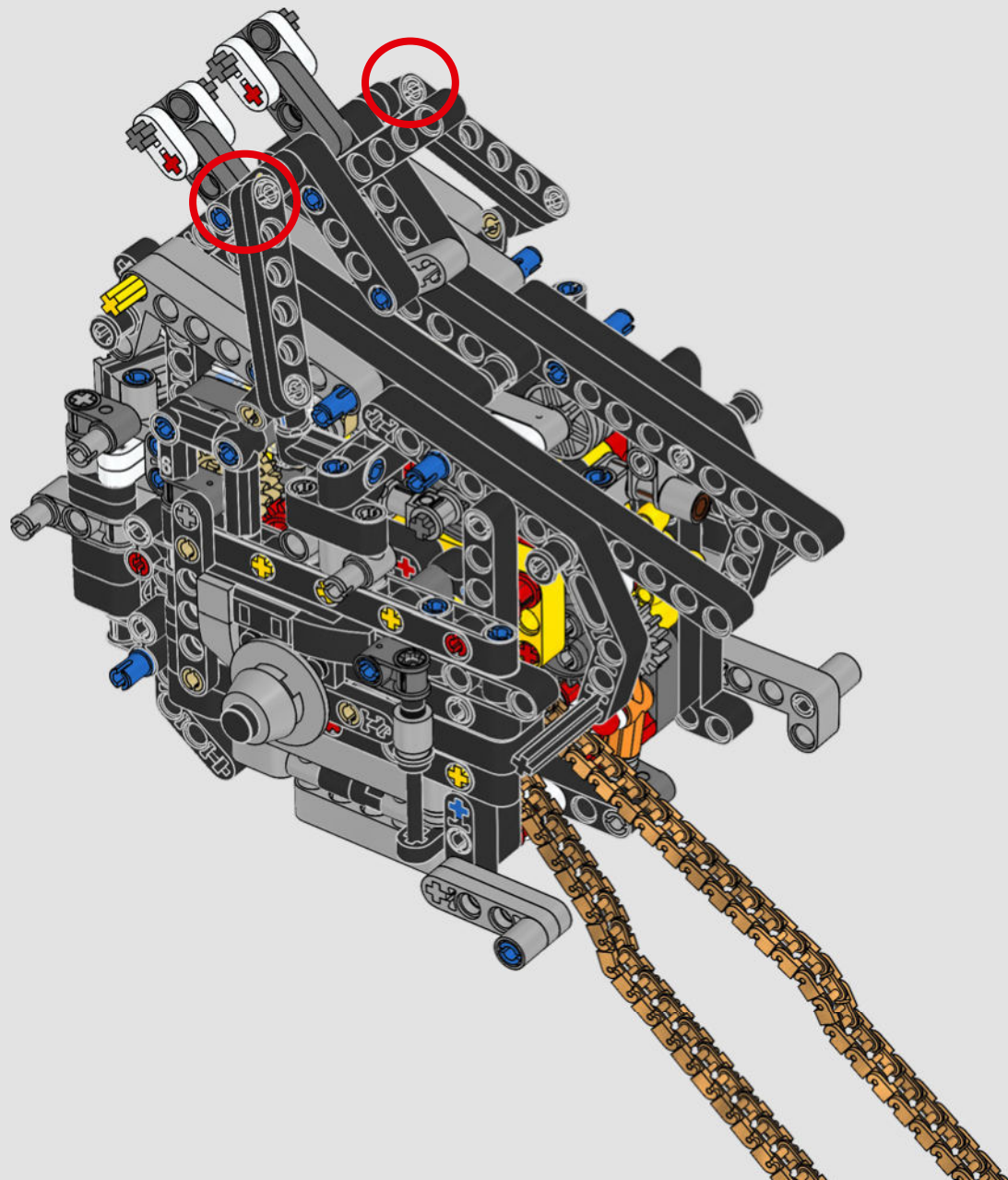

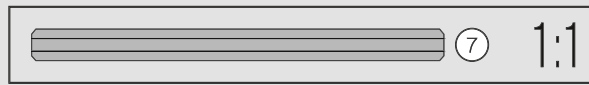
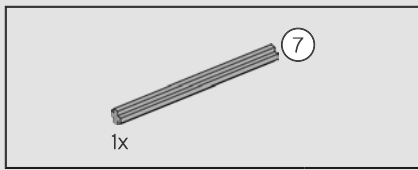

169

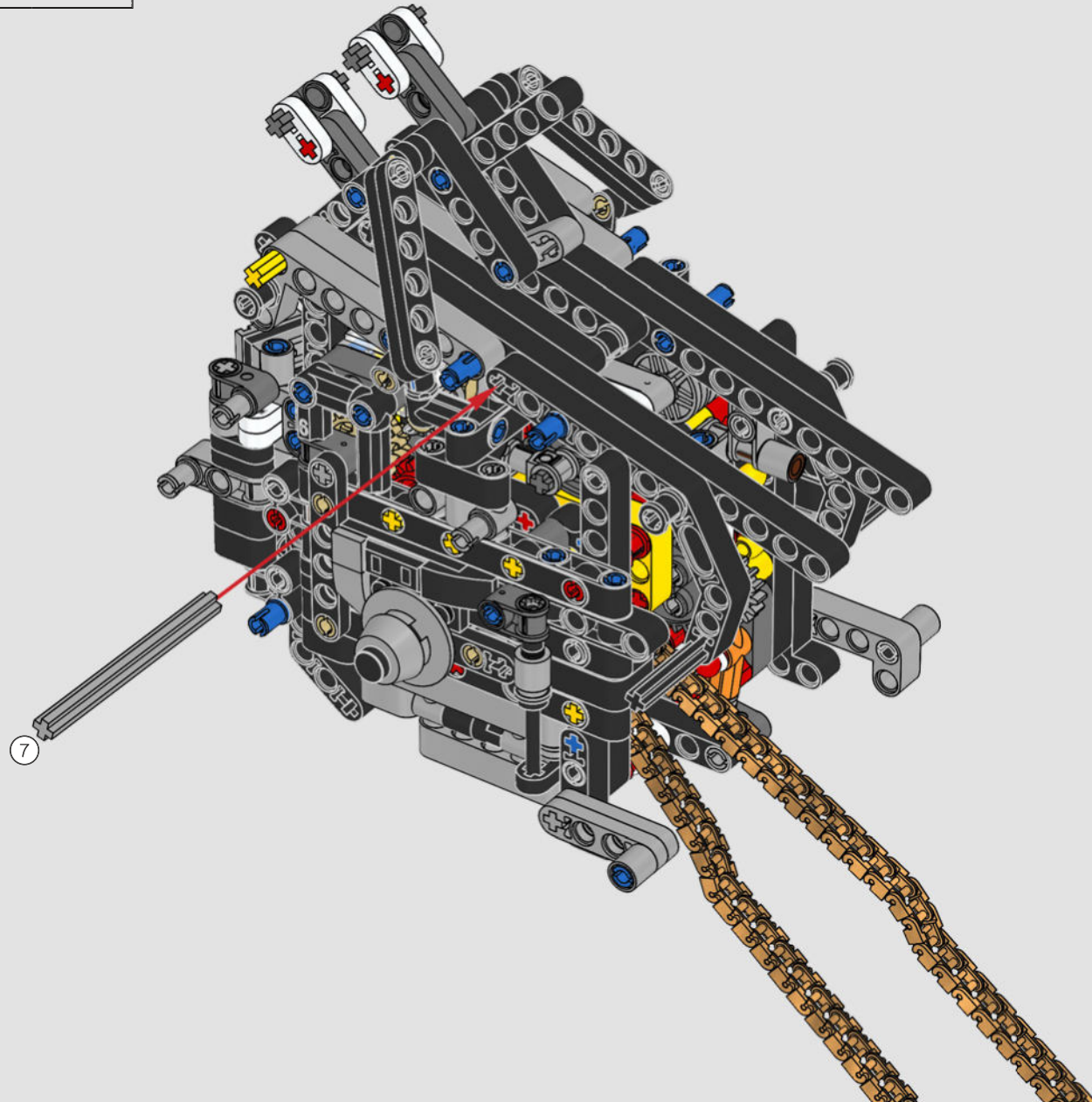



170

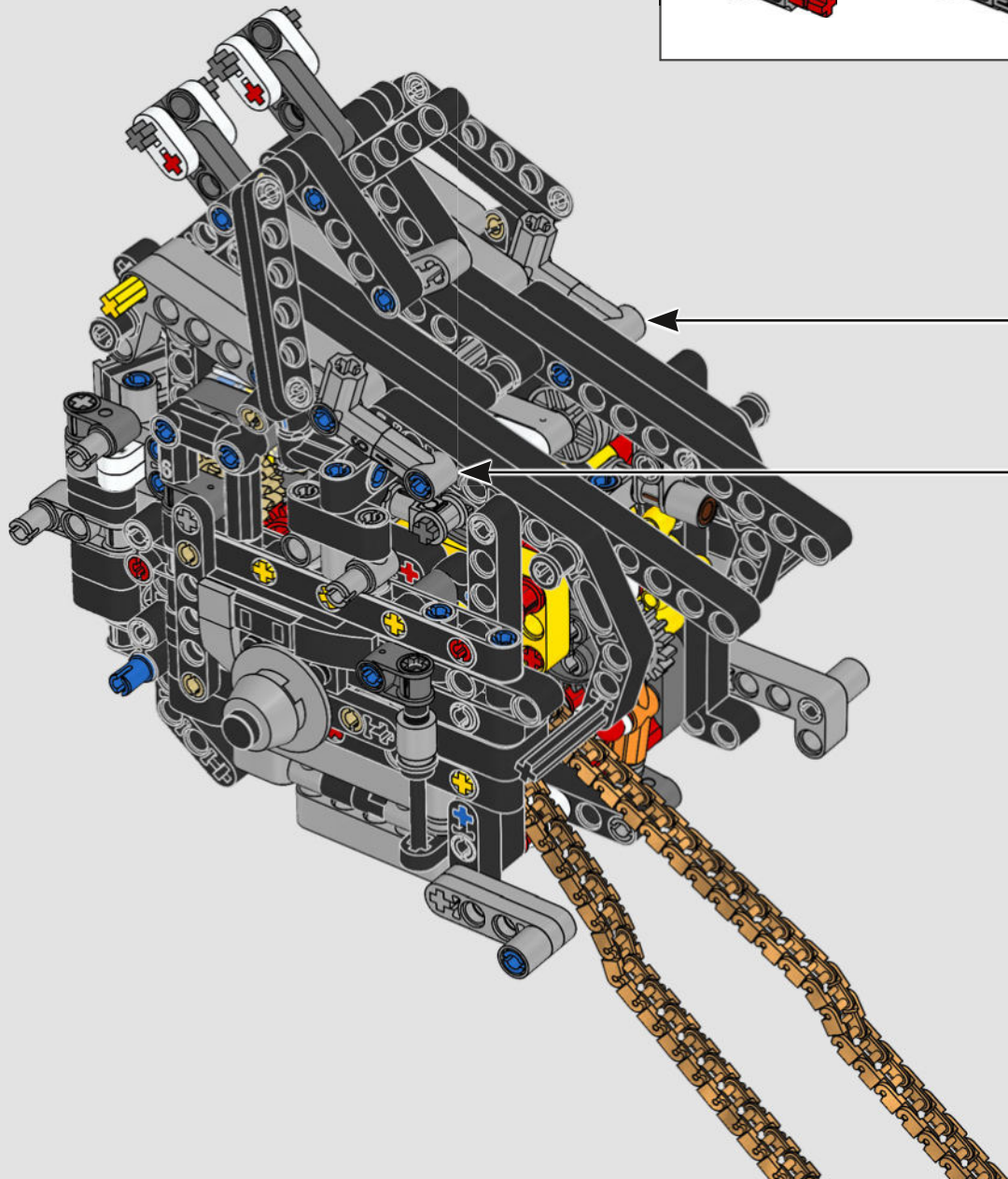
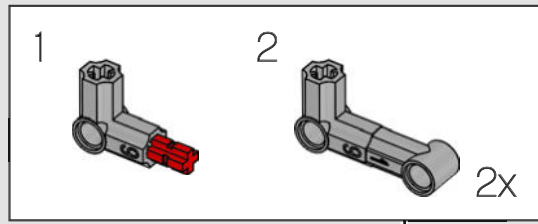

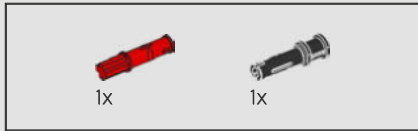
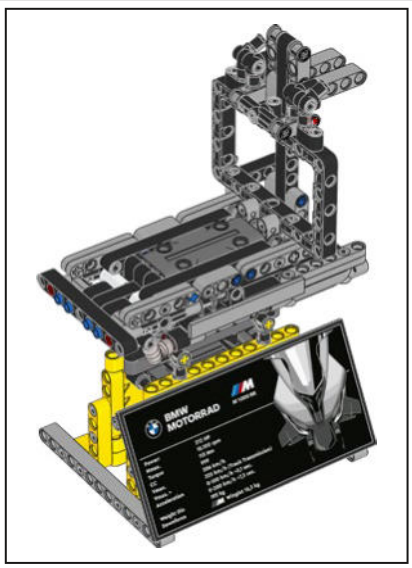

171

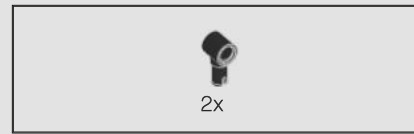

172

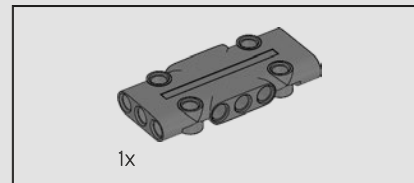

173

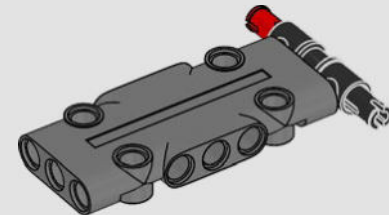

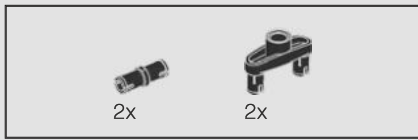

174

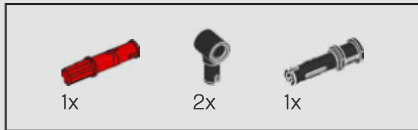
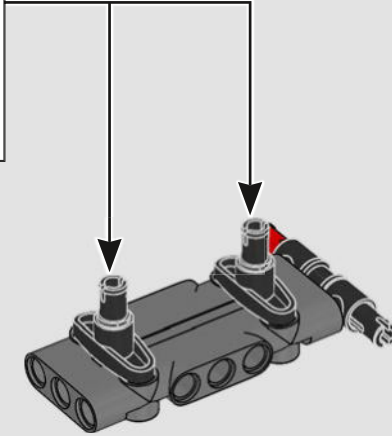
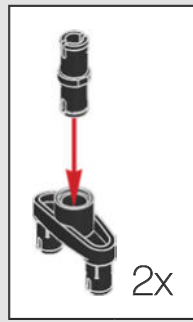

175

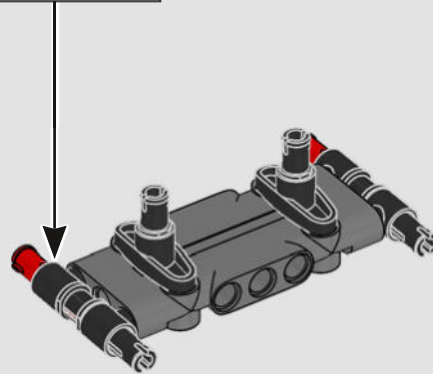
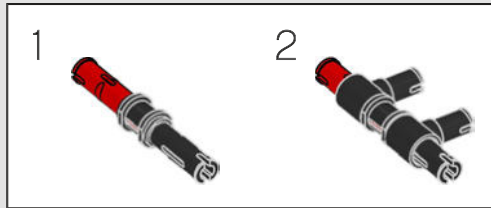

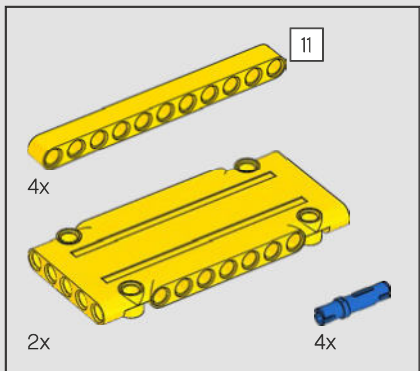

176

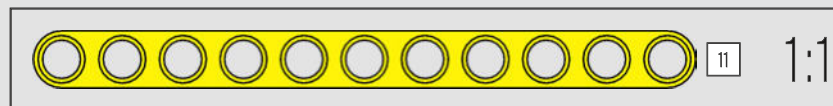
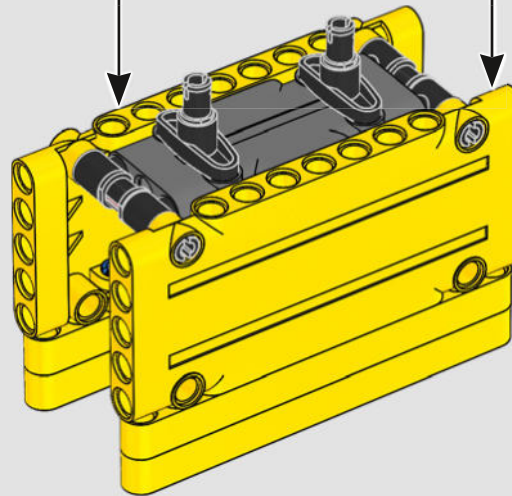
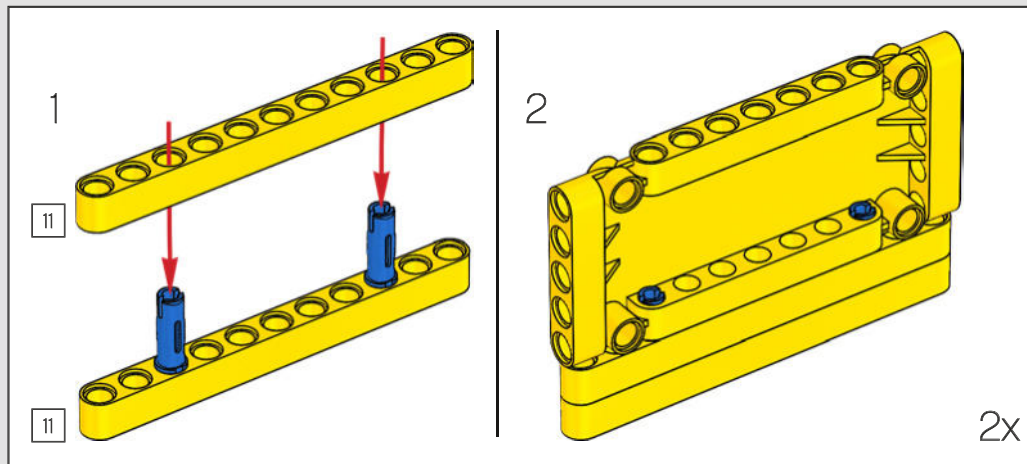

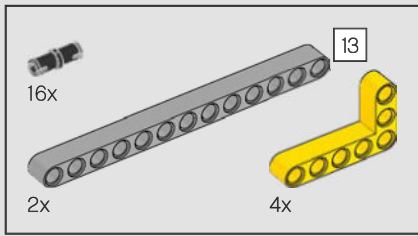

177

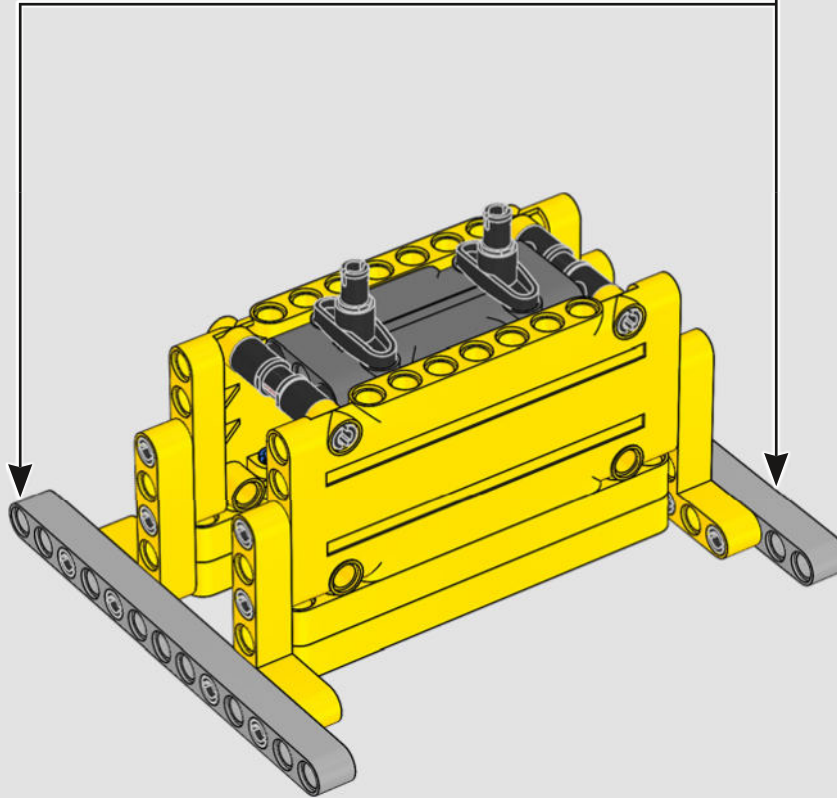
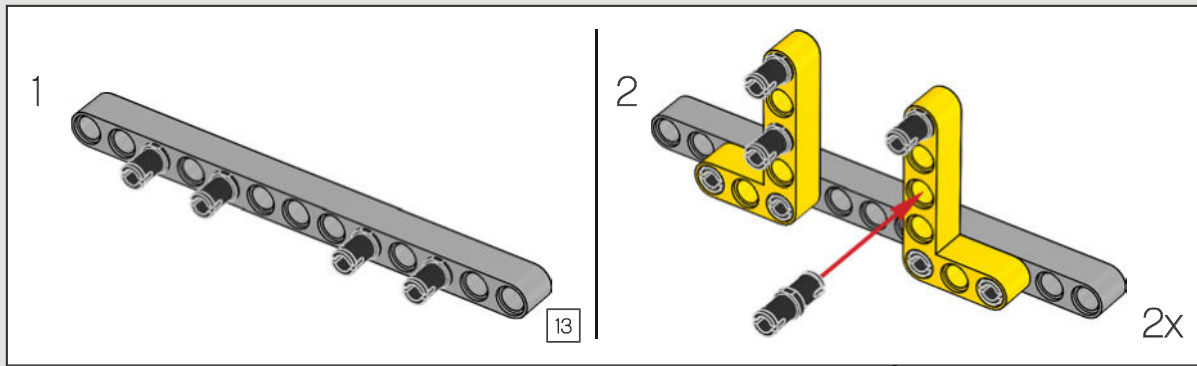

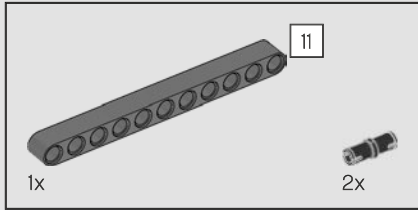
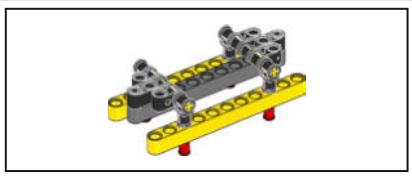

178

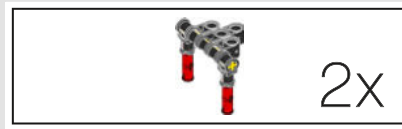
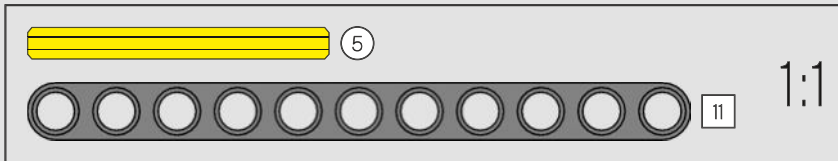
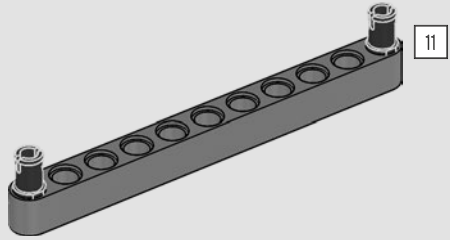

2x

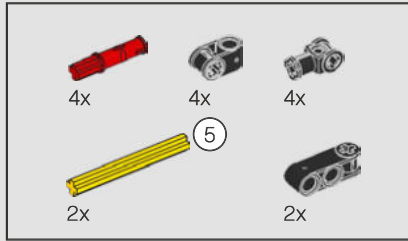

179

1

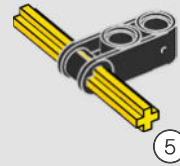

2

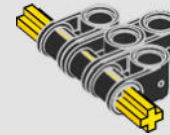

3

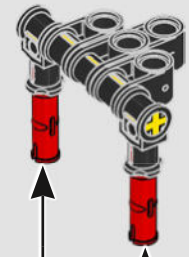

2x

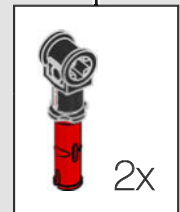

2x

180

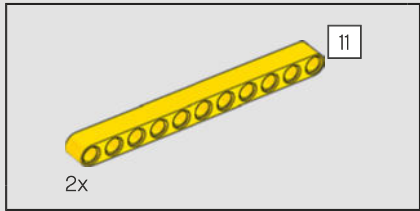
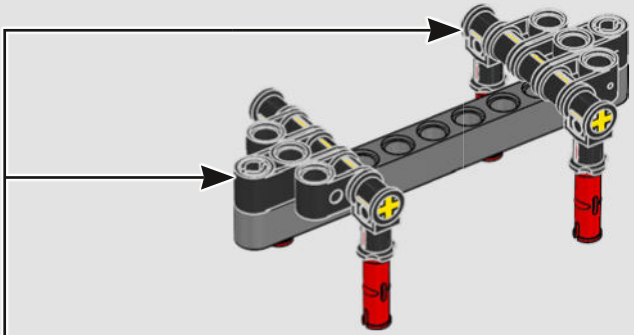

181

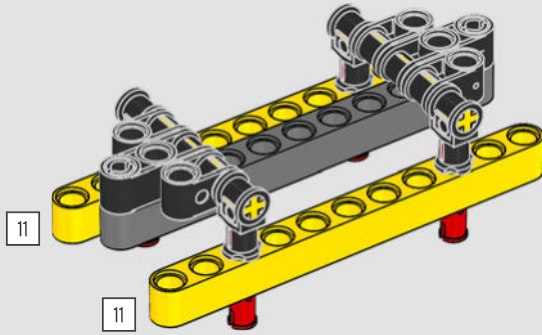

182

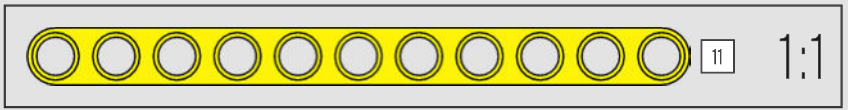
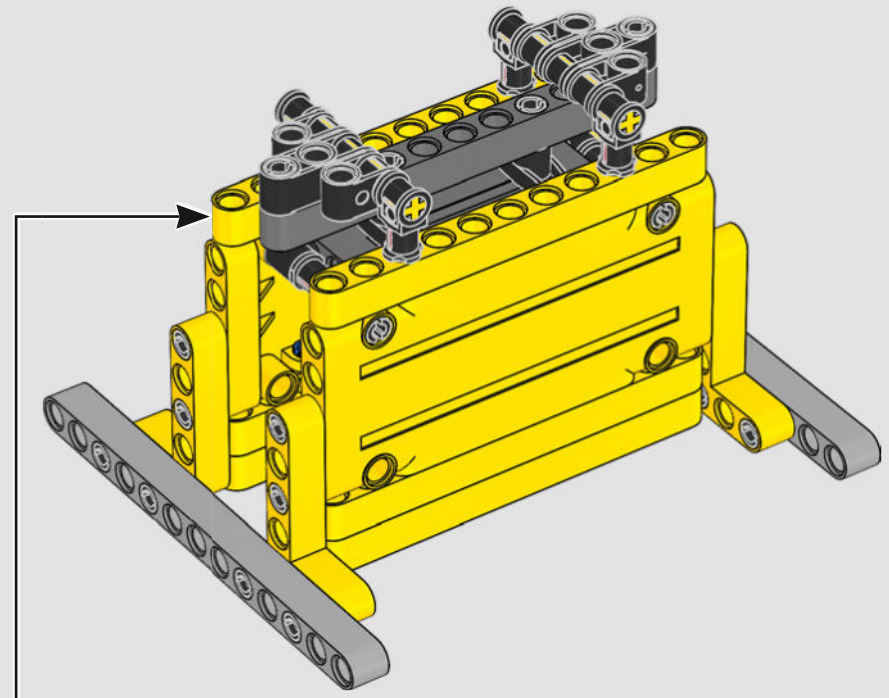

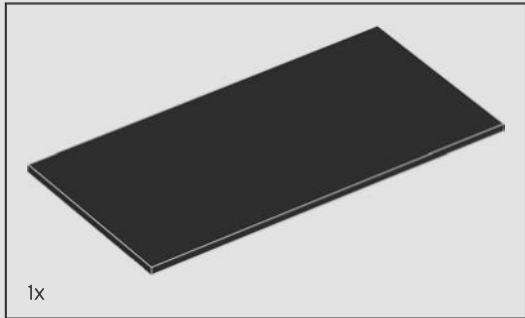
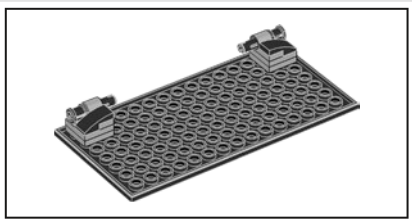

1x

183

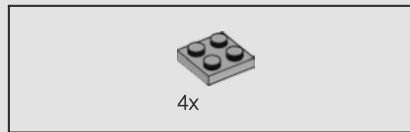
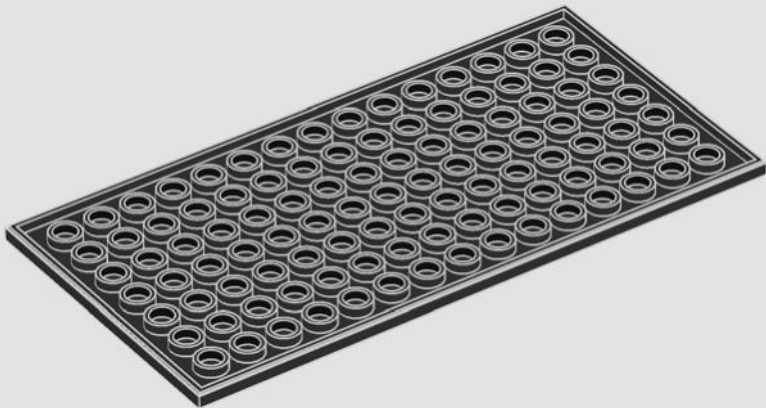

4x

184

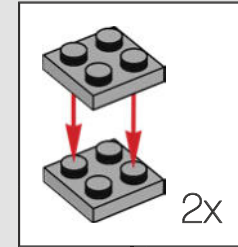

2x

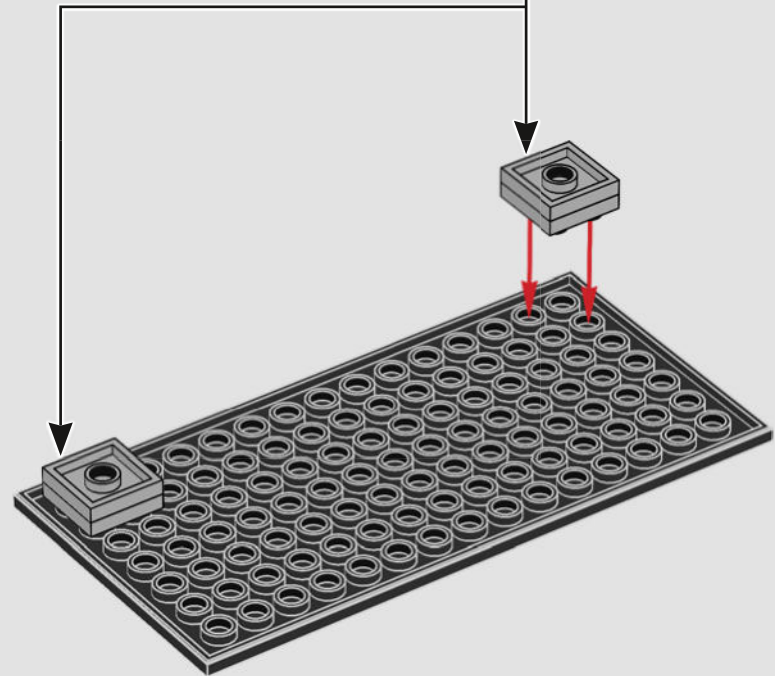



185

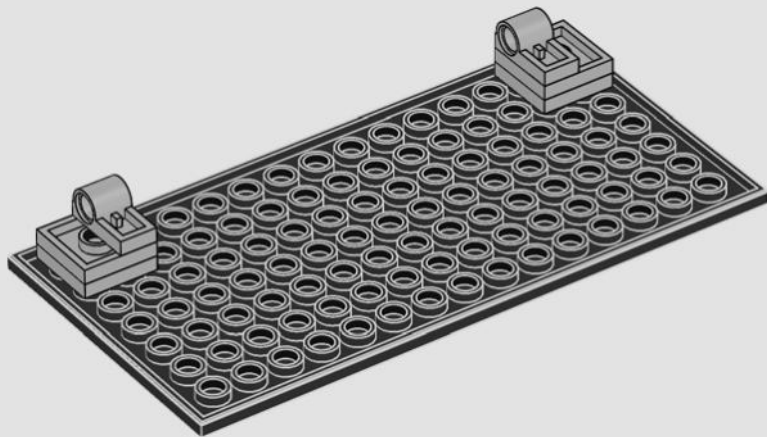

186

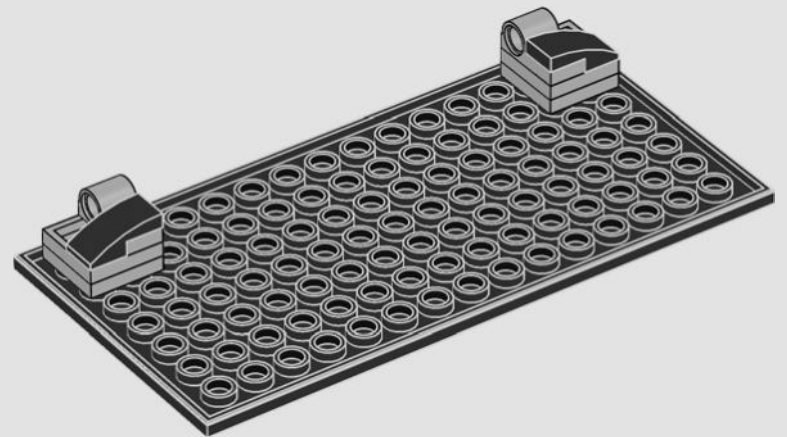



187

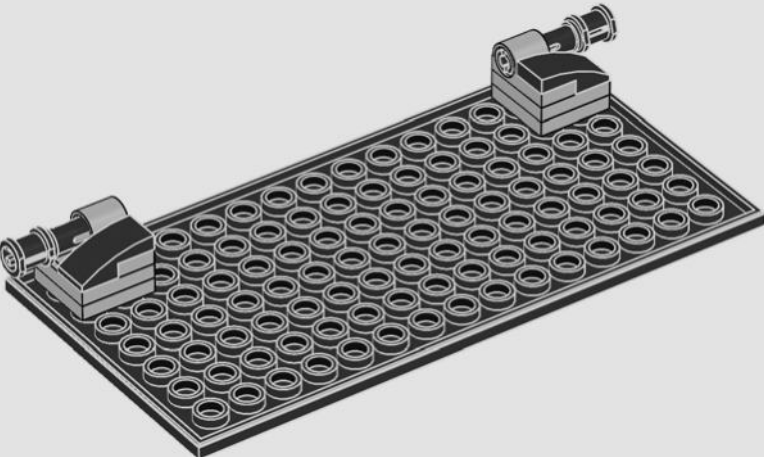

188

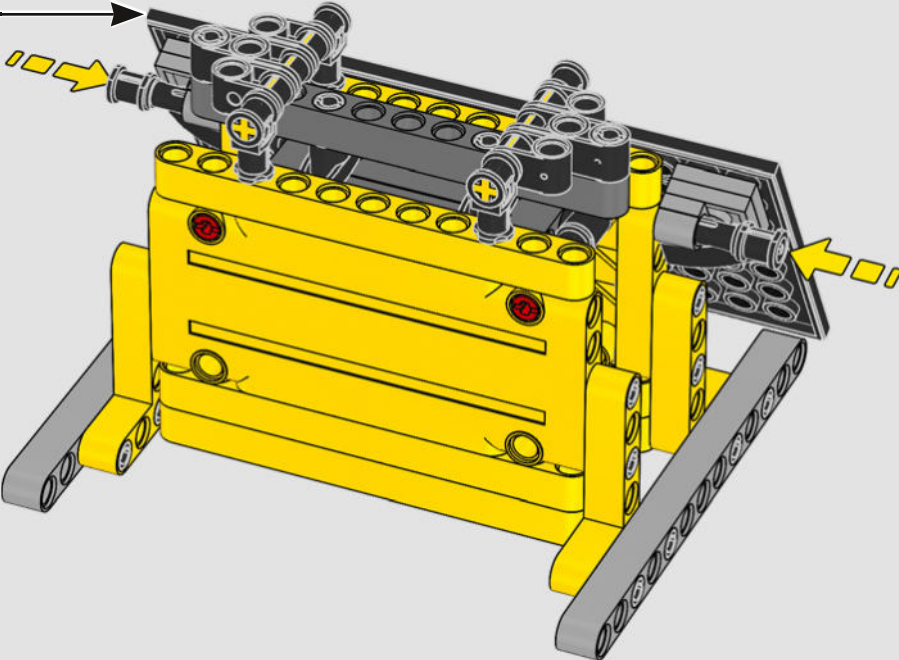

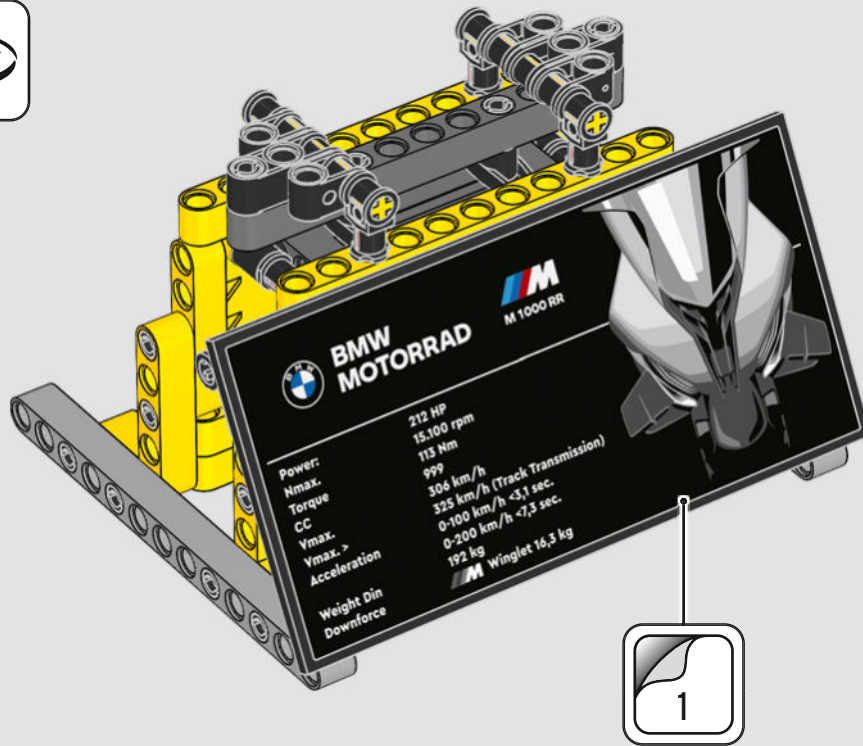

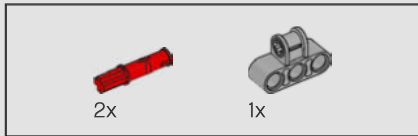
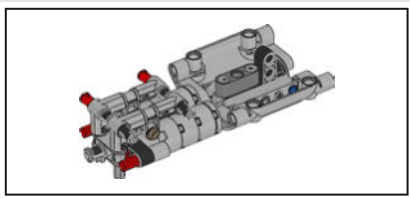

190

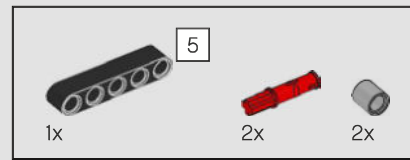
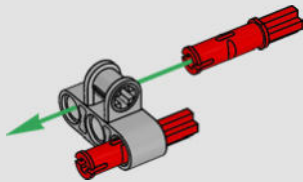

191

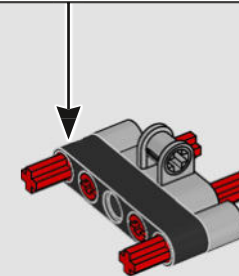
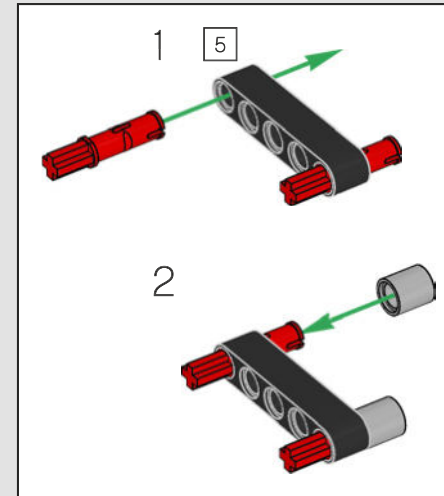

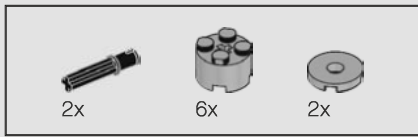

192

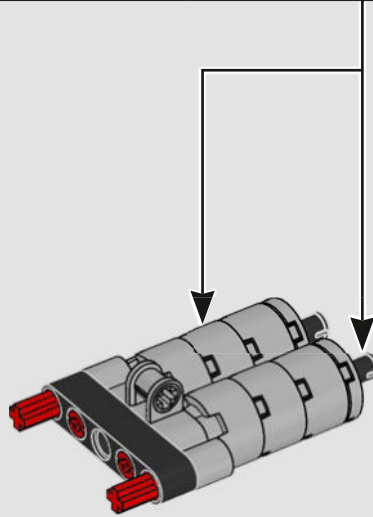
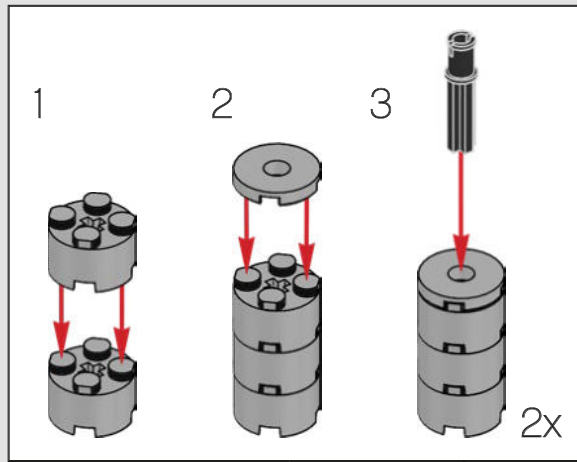

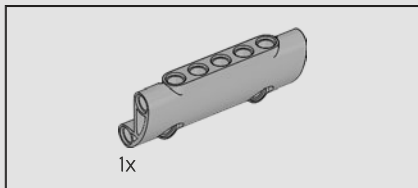
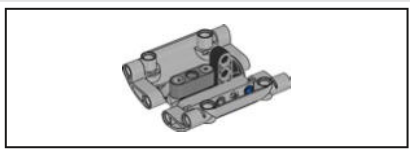

193

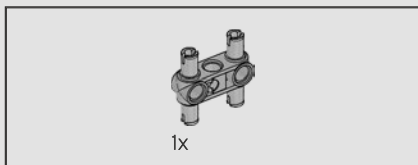
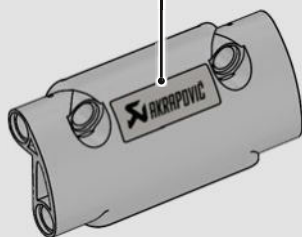

194

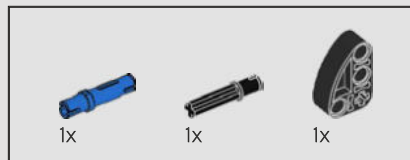
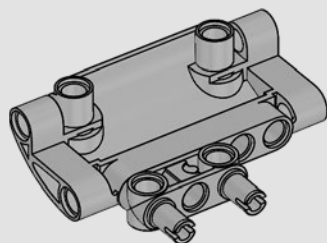

195

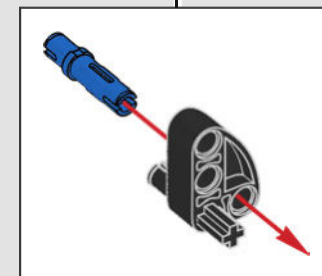
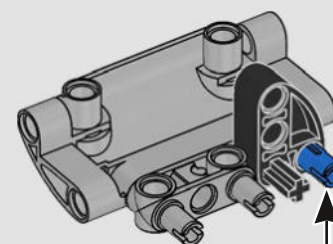

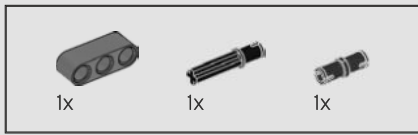

196

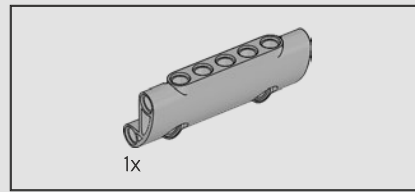
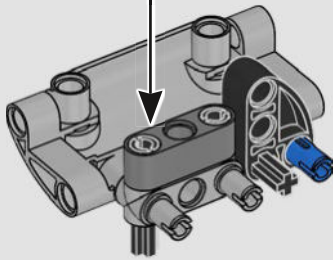
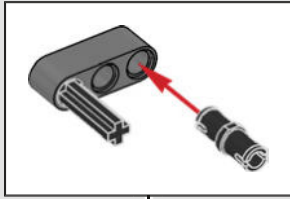

197

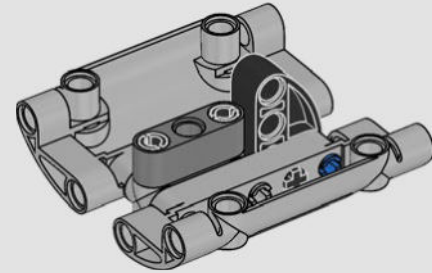
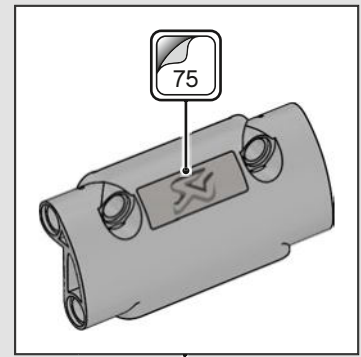

198

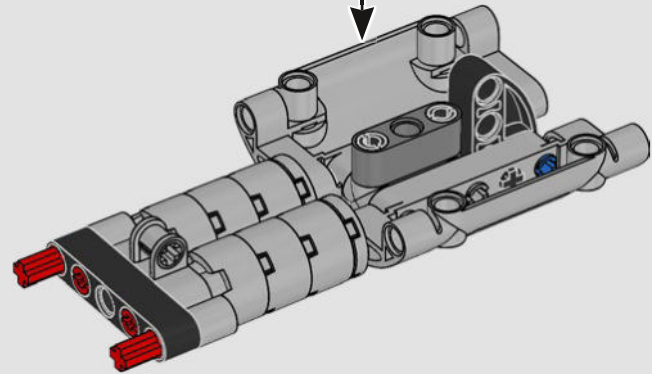

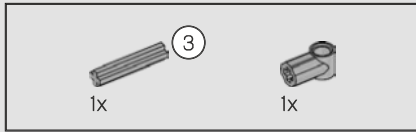
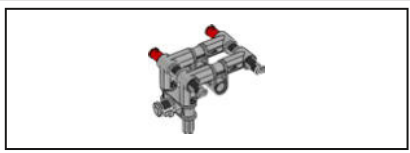

199

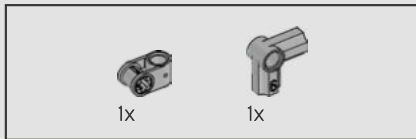
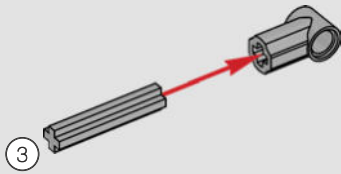

200

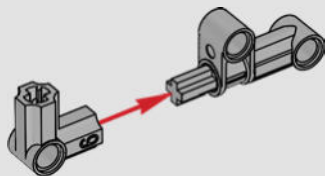

201

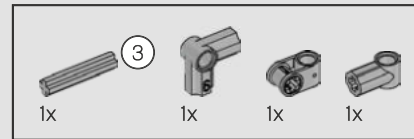
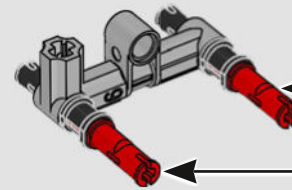

202

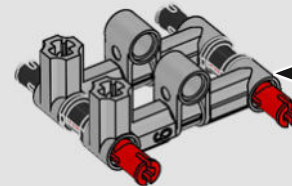
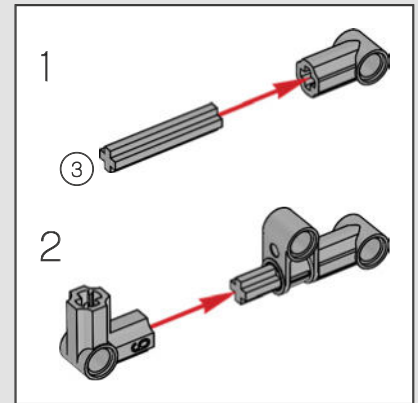

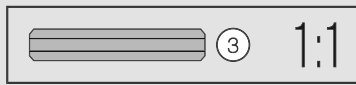
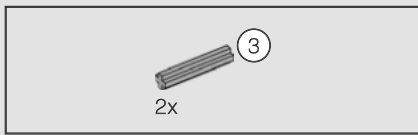

203

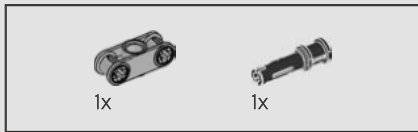
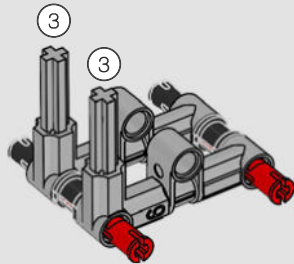

204

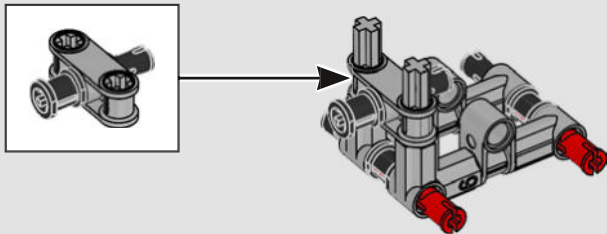

205

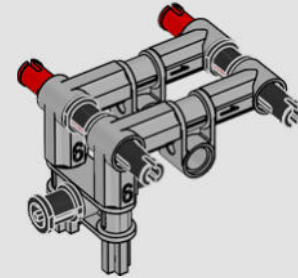

206

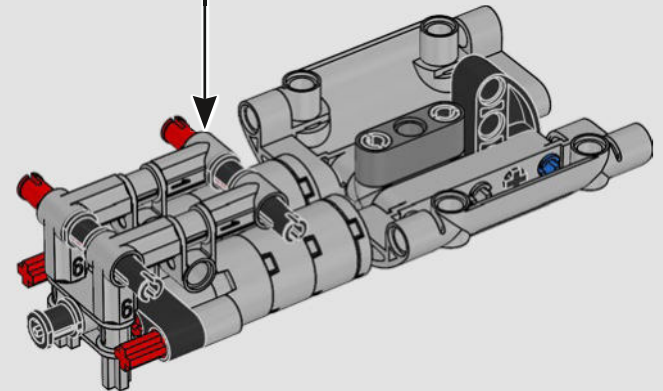

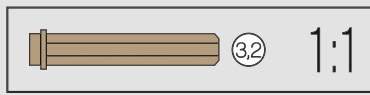
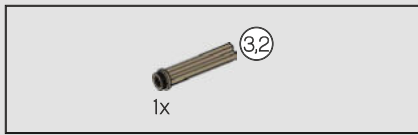

207

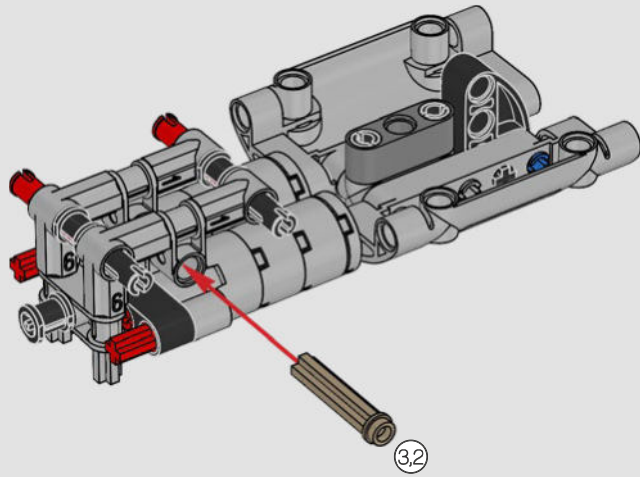

208

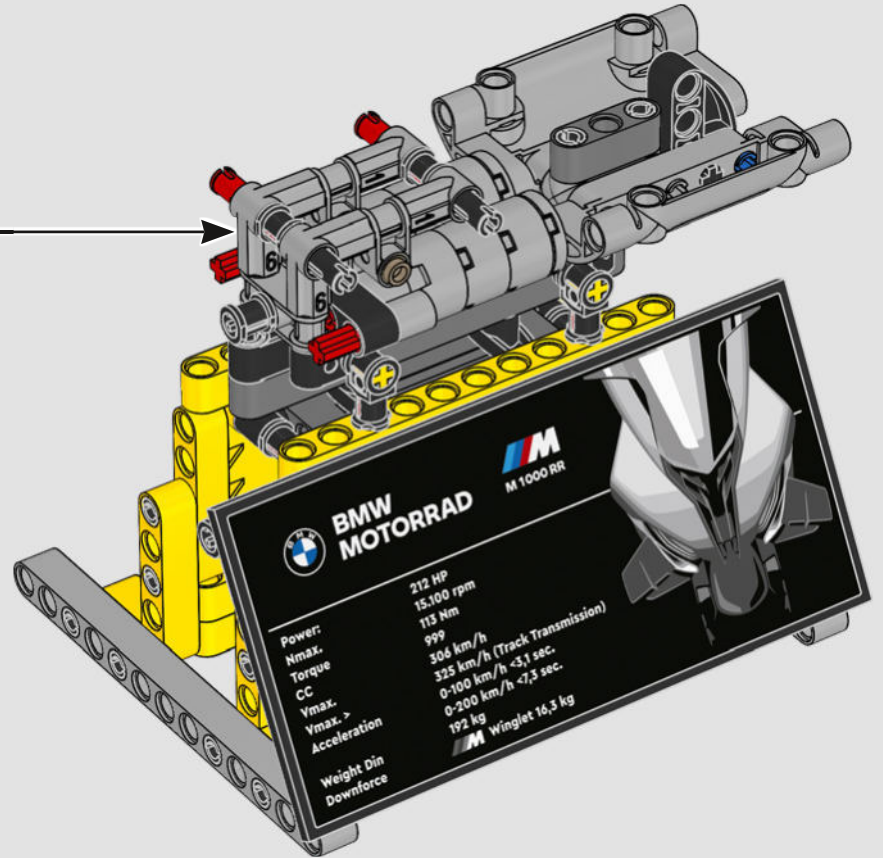

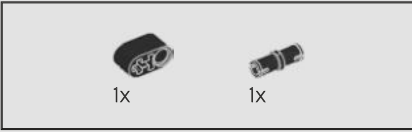
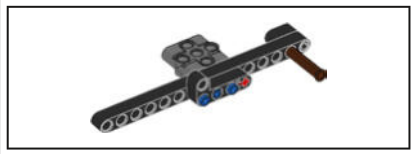

209

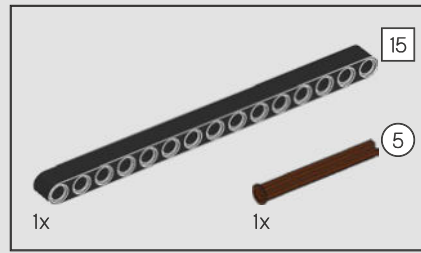
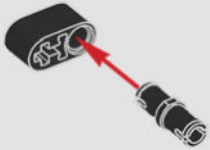

210

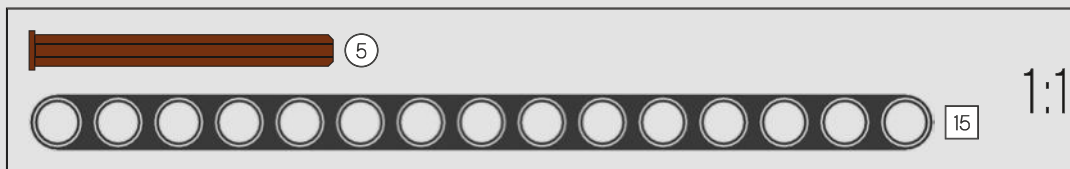
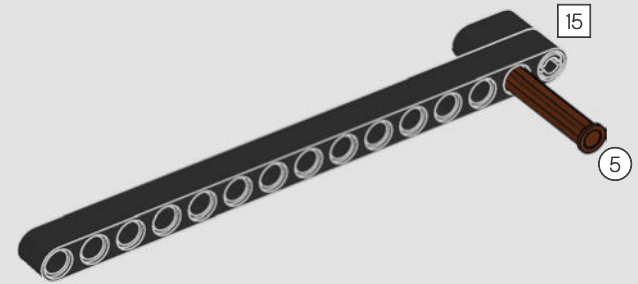

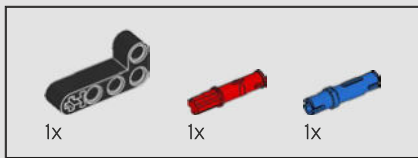

211

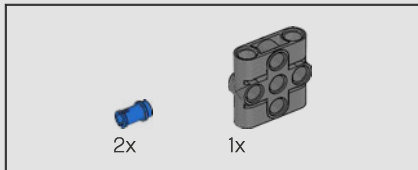
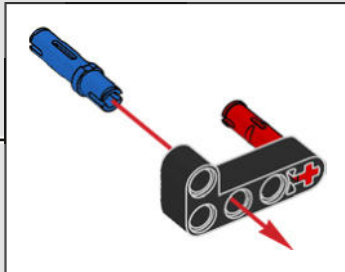
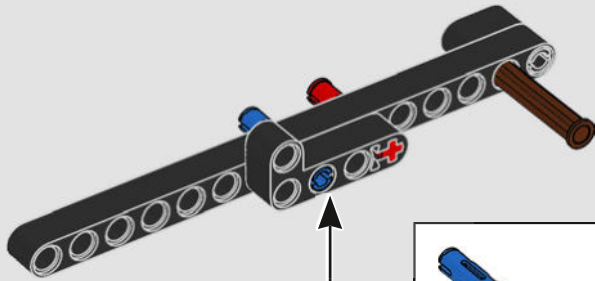

212

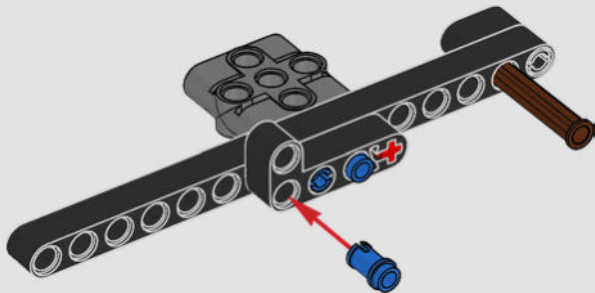

213

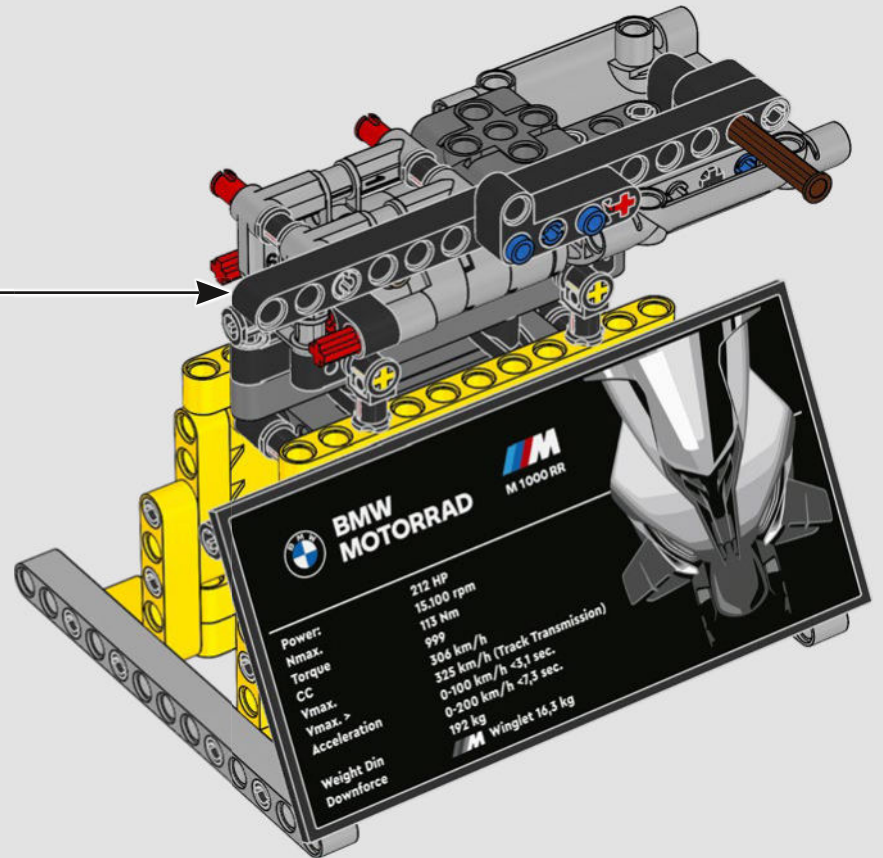

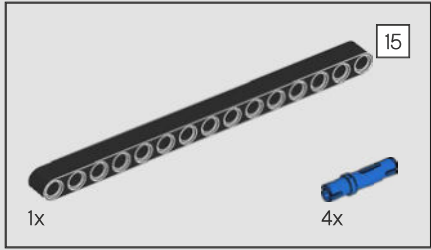
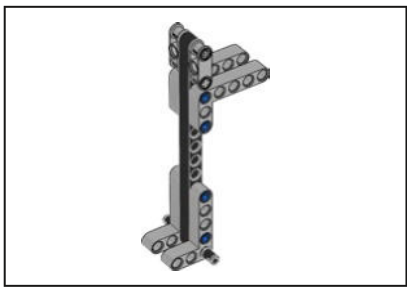

214

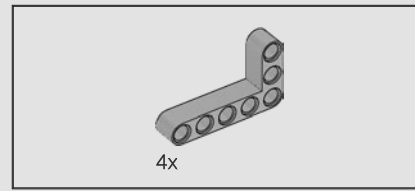
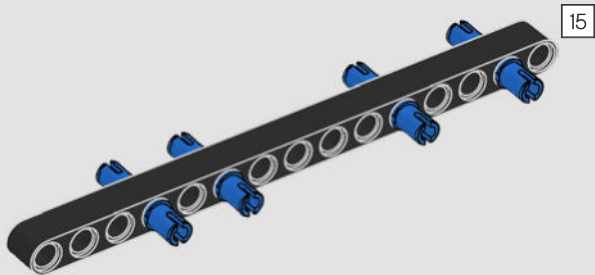

215

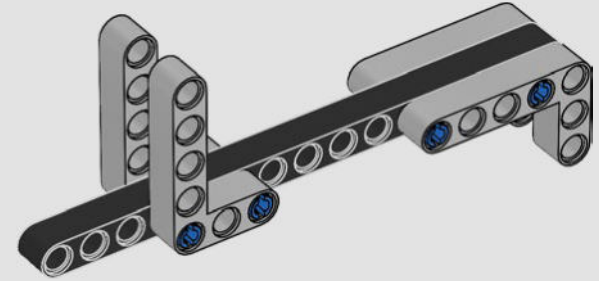

216

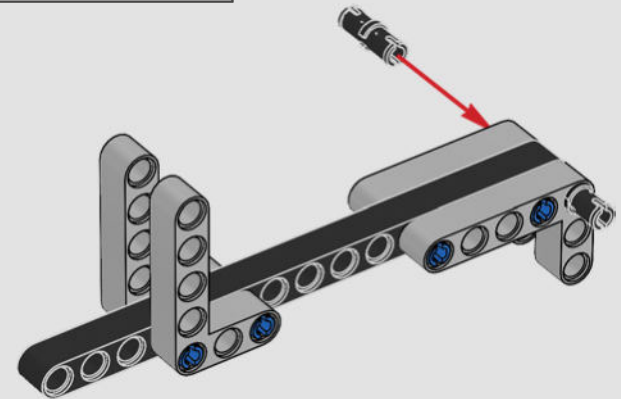

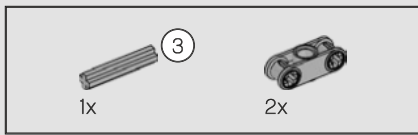

217

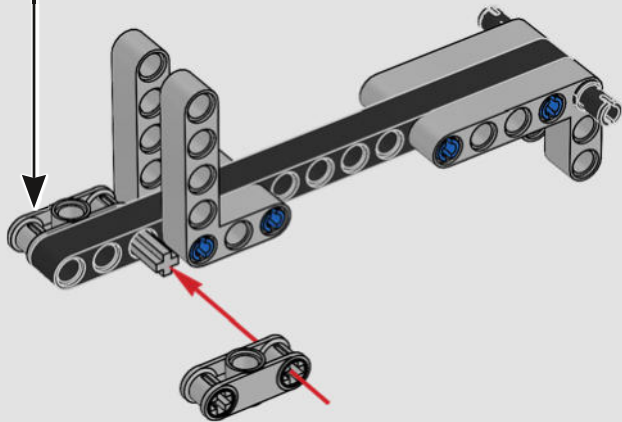
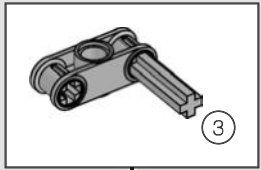

218

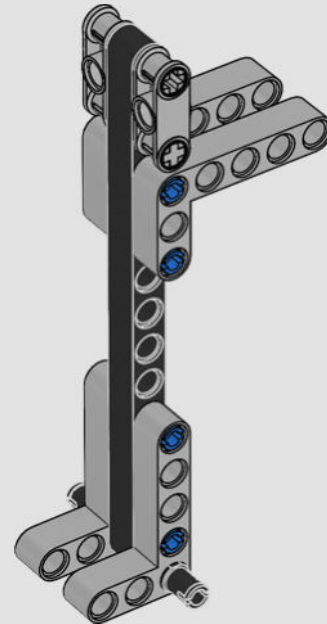

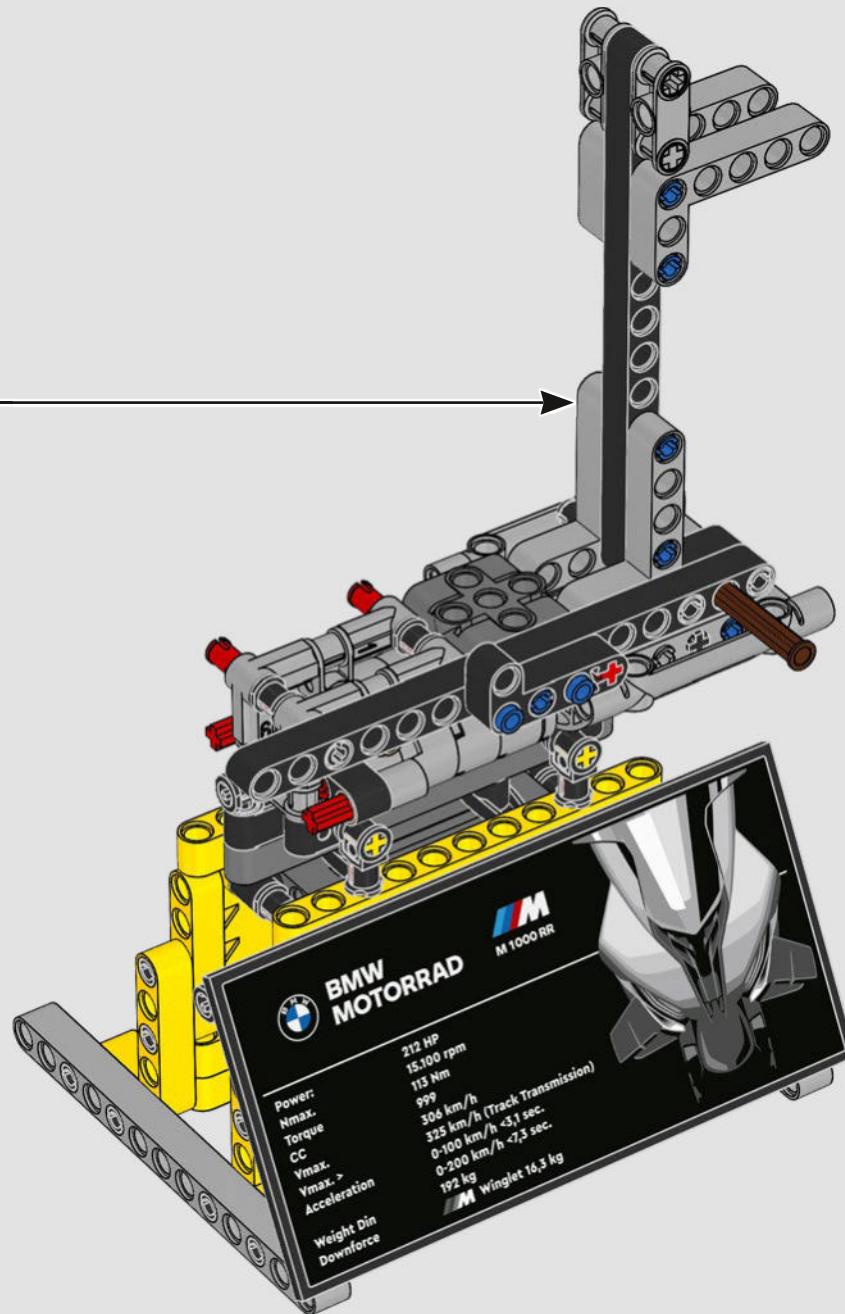

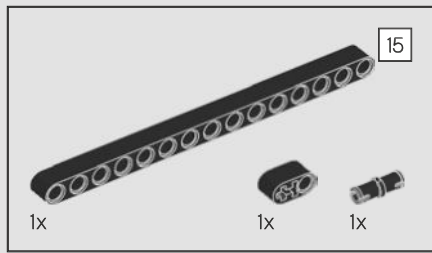

220

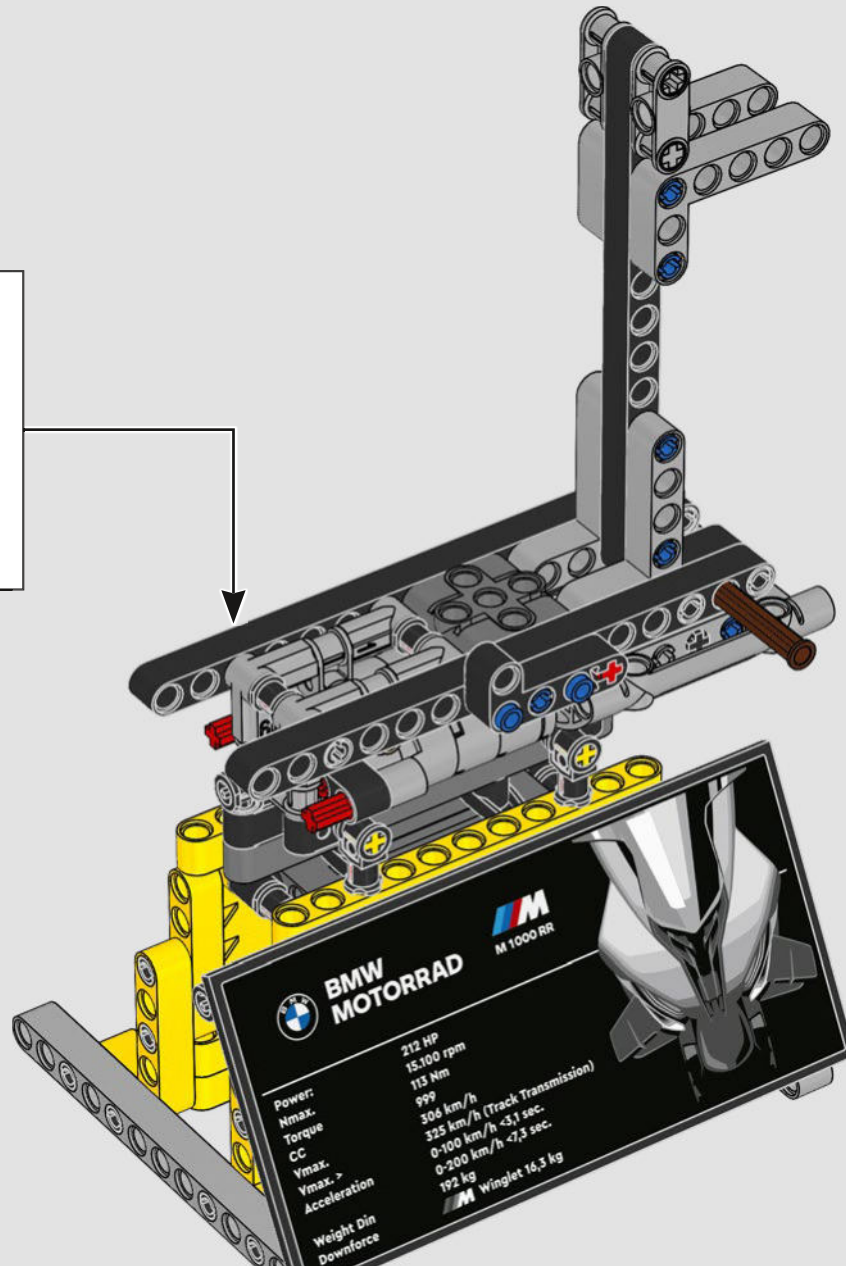
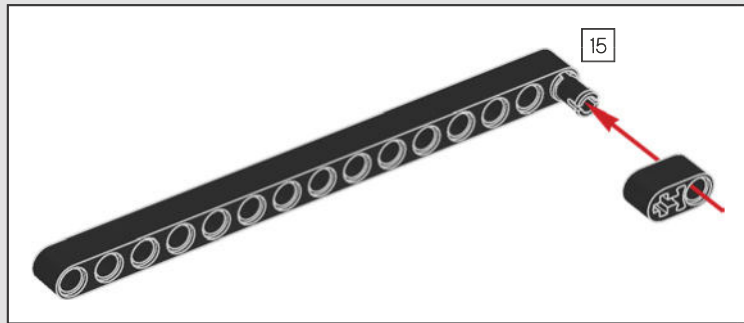

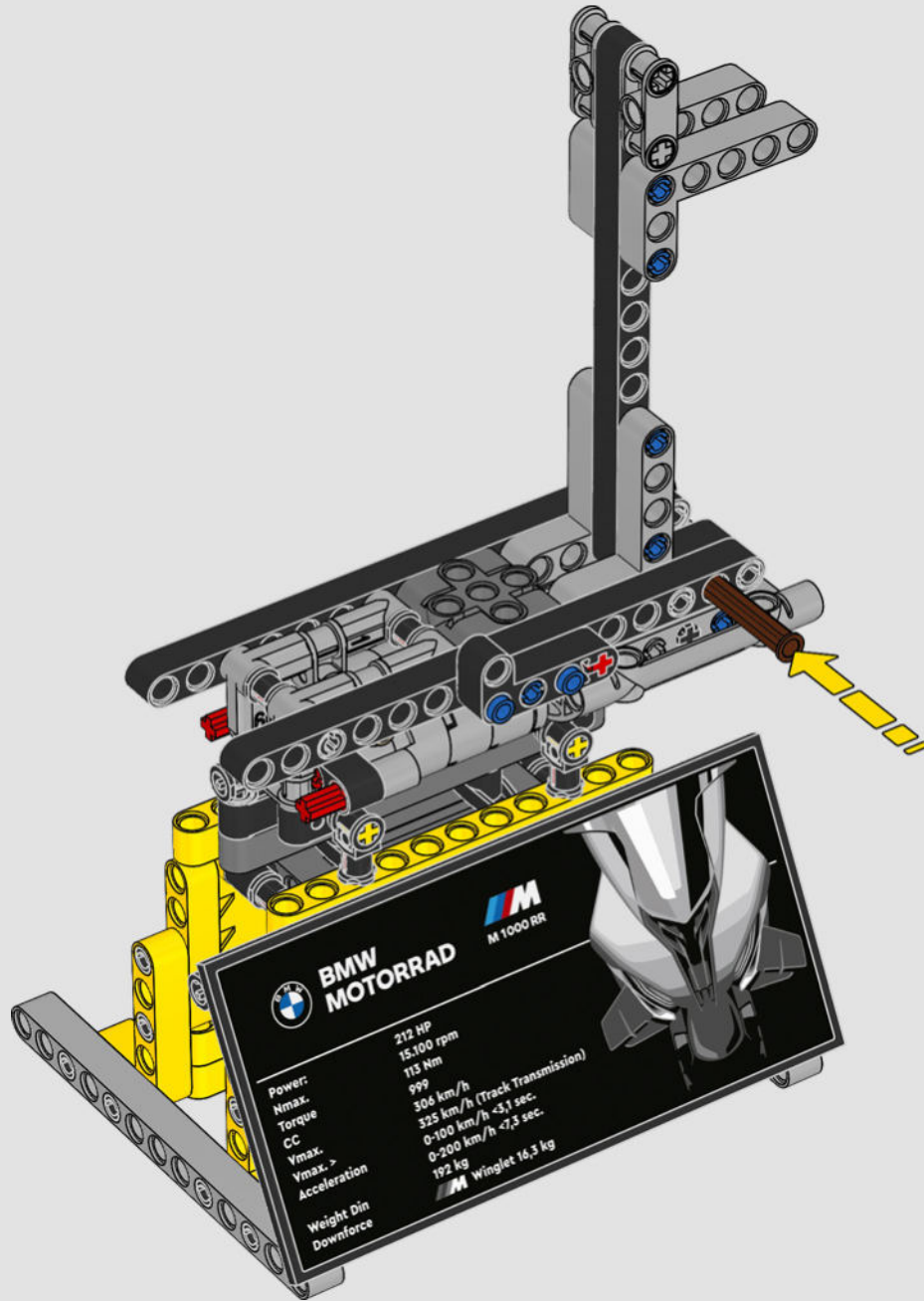

221

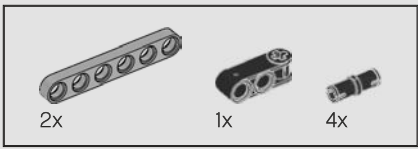

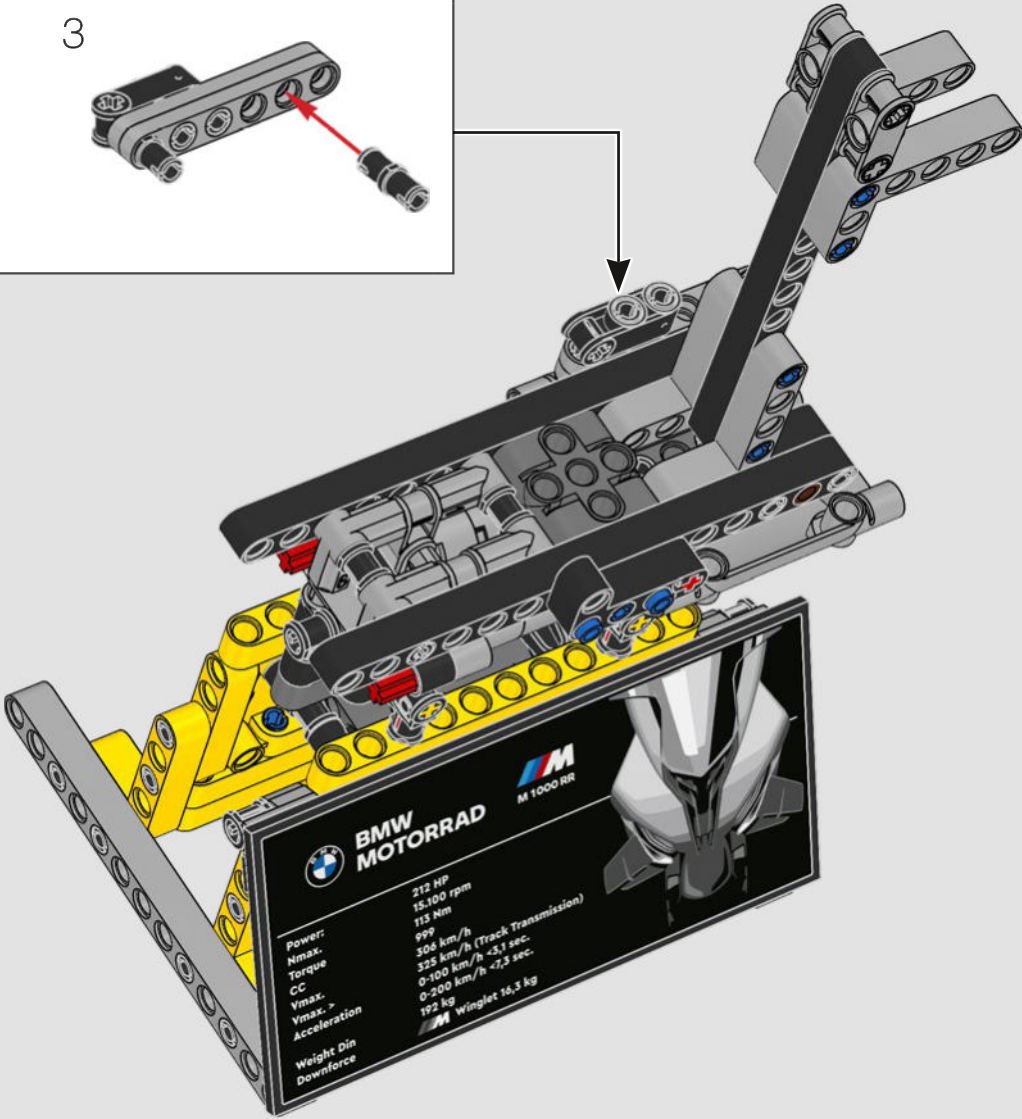
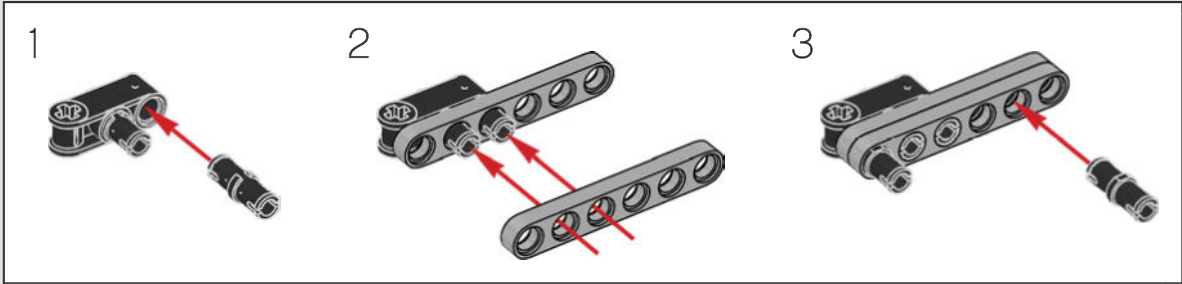

222



BMW MOTORRAD  M 1000 RR

Power: 212 HP
 15,100 rpm
 113 Nm
 999
 Nmax.: 204 km/h (Track Transmission)
 Torque: 225 km/h <math>< 3,1 \text{ sec.}</math>
 CC: 0-100 km/h <math>< 7,3 \text{ sec.}</math>
 Vmax.: 0-200 km/h <math>< 7,3 \text{ sec.}</math>
 Vmax. > Acceleration: 192 kg
 Weight Din: 192 kg
 Downforce:  Winglet 16,3 kg

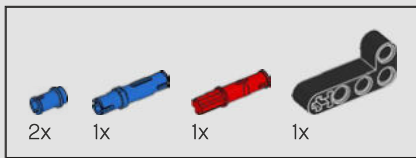

223

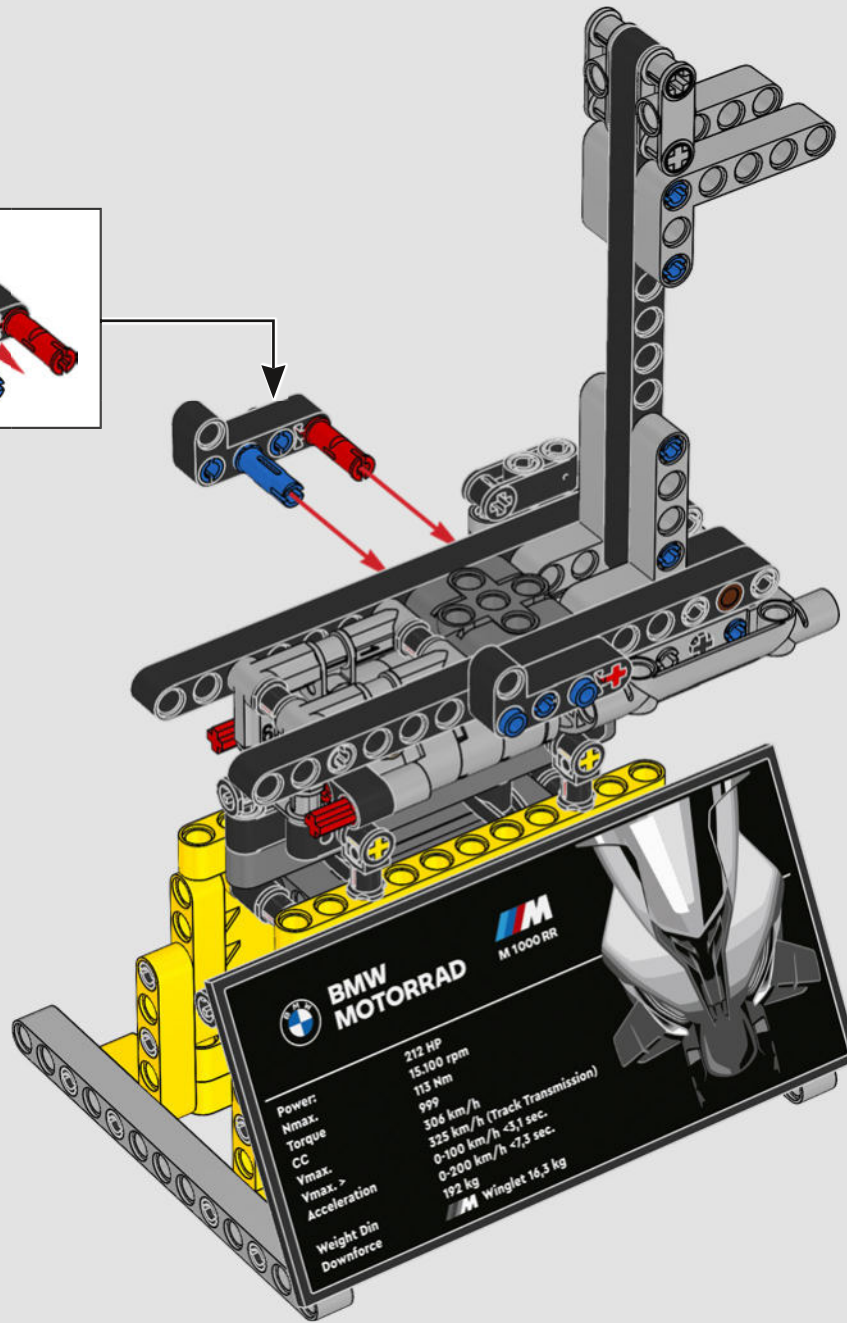
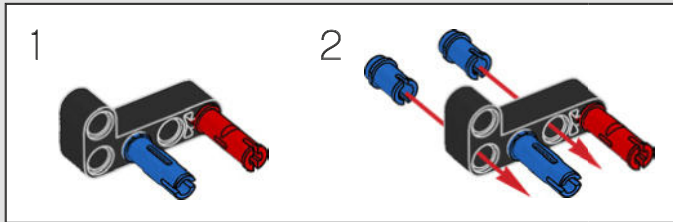

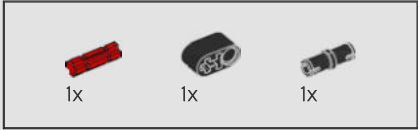
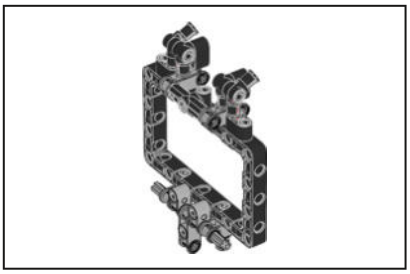

224

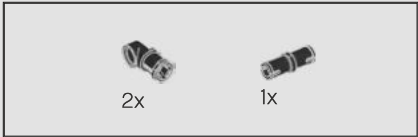
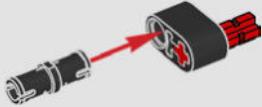

225

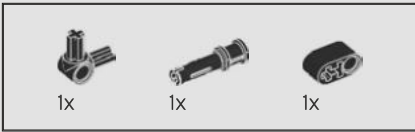
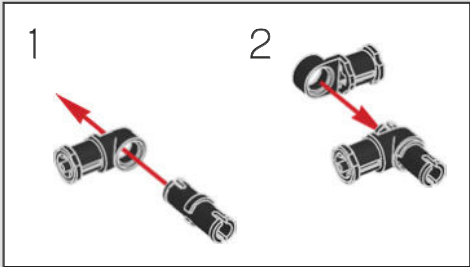

226

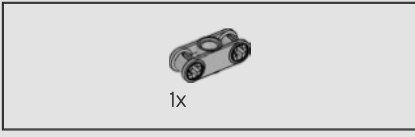
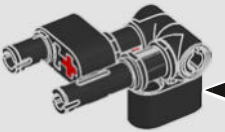
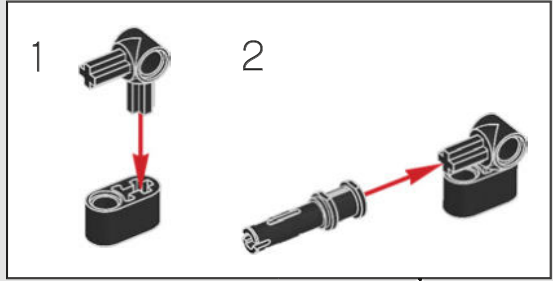

227

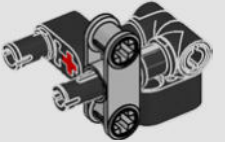

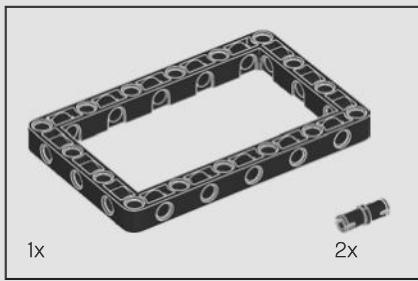

228

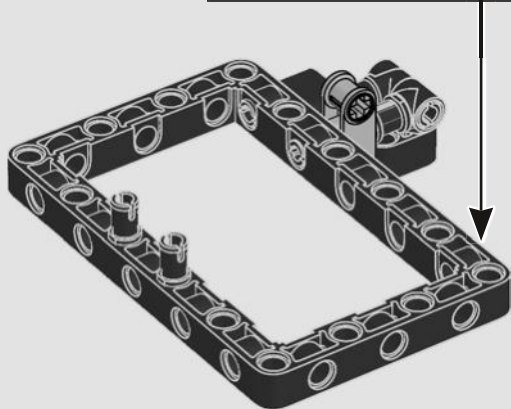
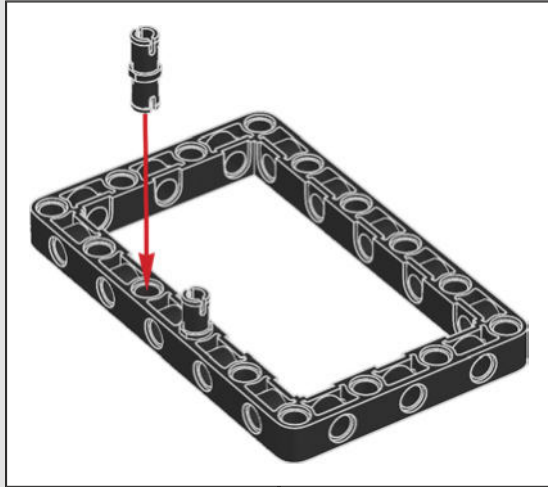

229

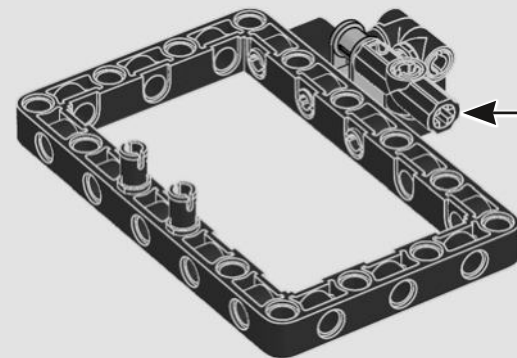
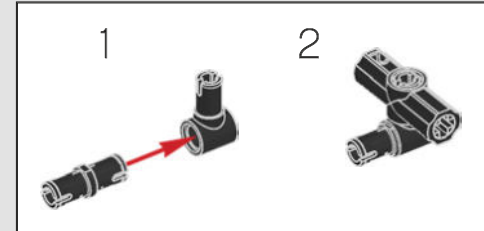



230

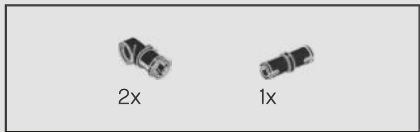

231

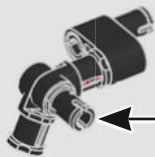
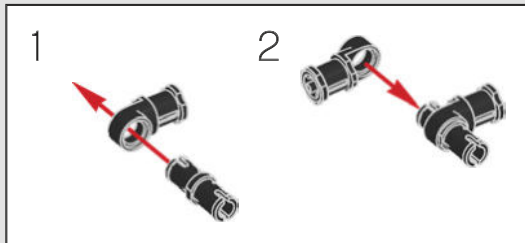

232

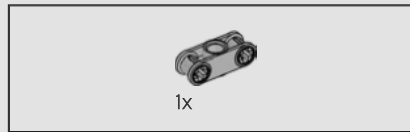
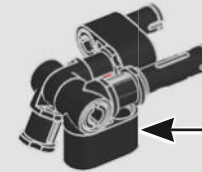
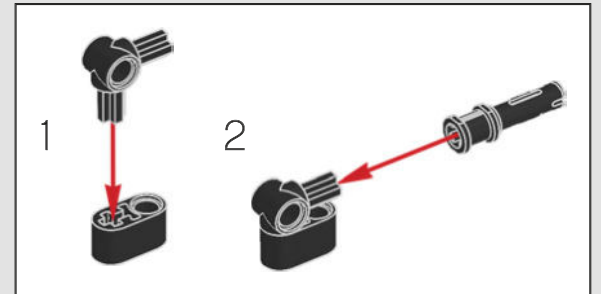

233



234

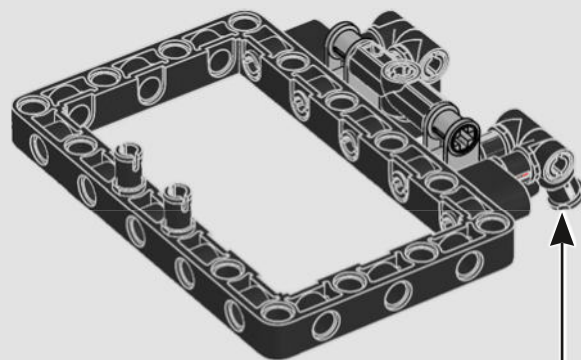

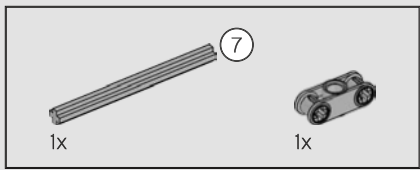

235

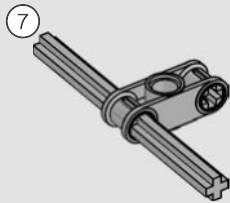

236

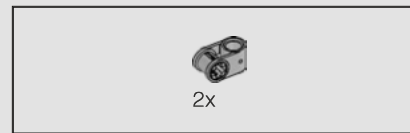
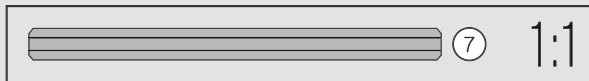
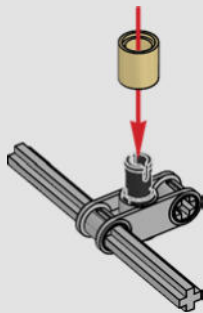

237

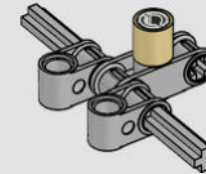

238

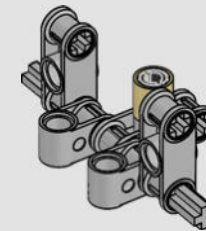

239

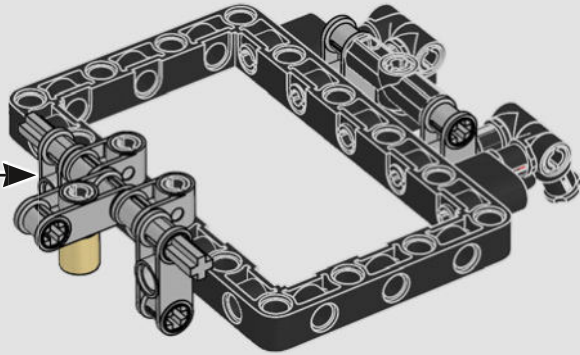

240

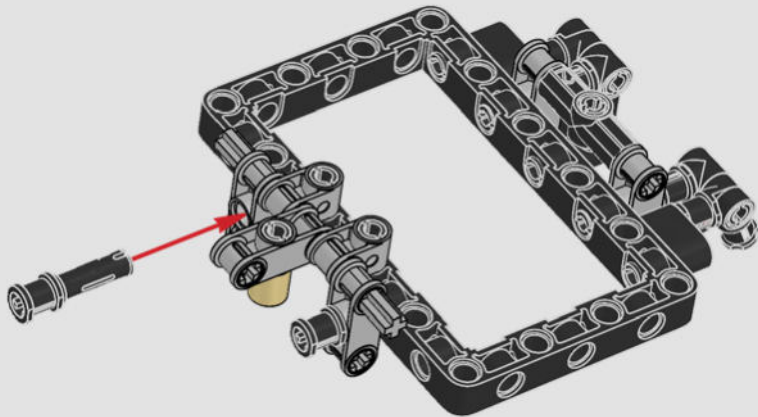

241

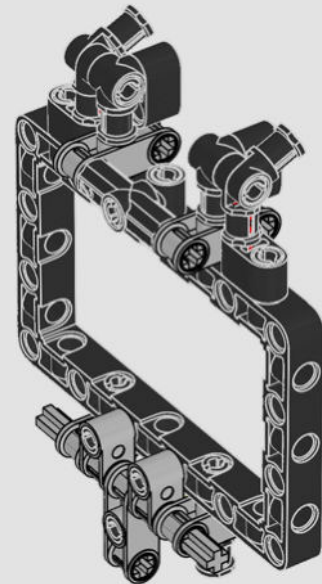

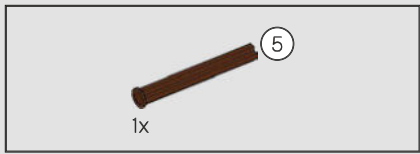

242

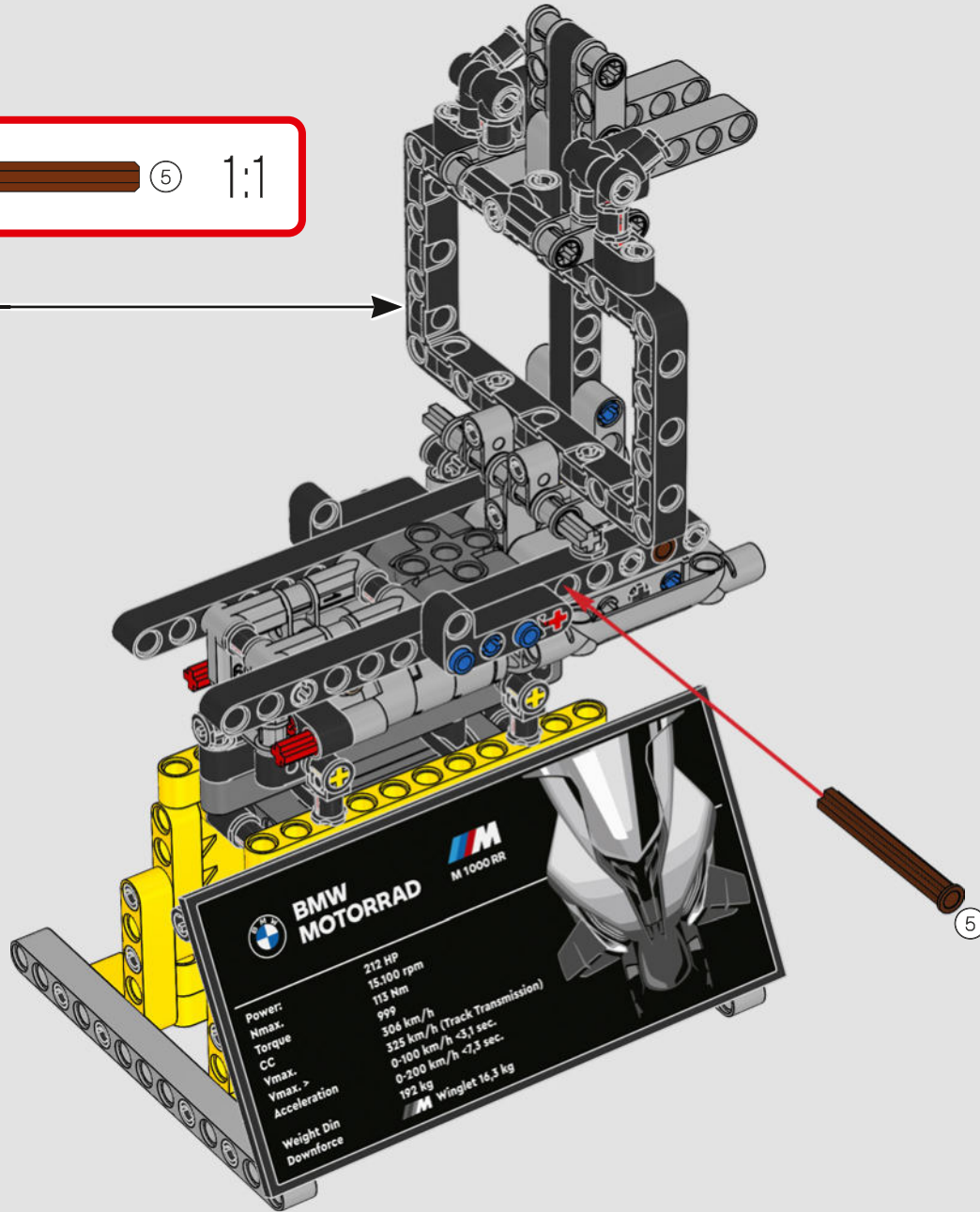
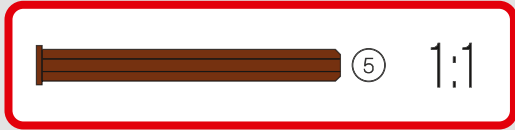

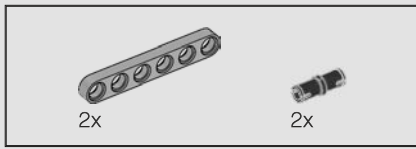

243

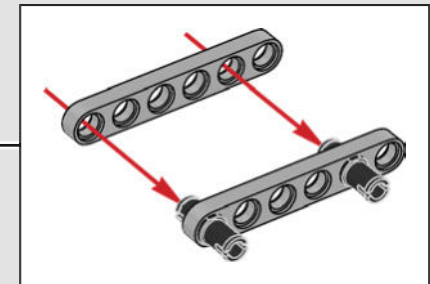
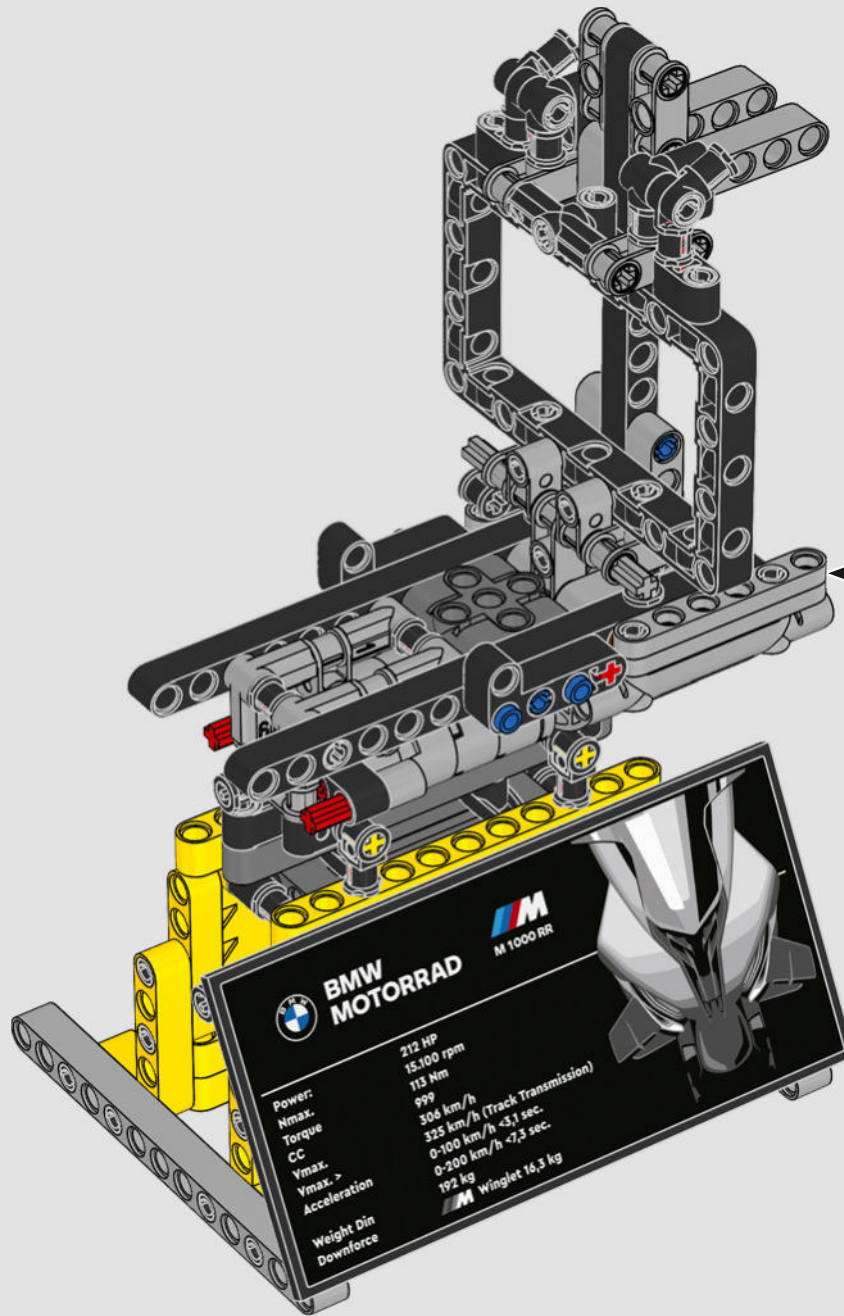

BMW MOTORRAD
M 1000 RR

Power:	212 HP
Nmax:	15.100 rpm
Torque	113 Nm
CC	999
Vmax:	306 km/h (Track Transmission)
Ymax:	325 km/h <3,1 sec.
Acceleration	0-100 km/h <7,3 sec.
Weight Din	192 kg
Downforce	Winglet 16,3 kg

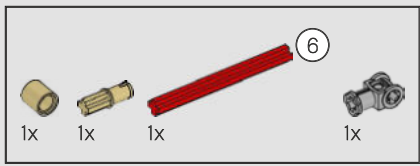

244

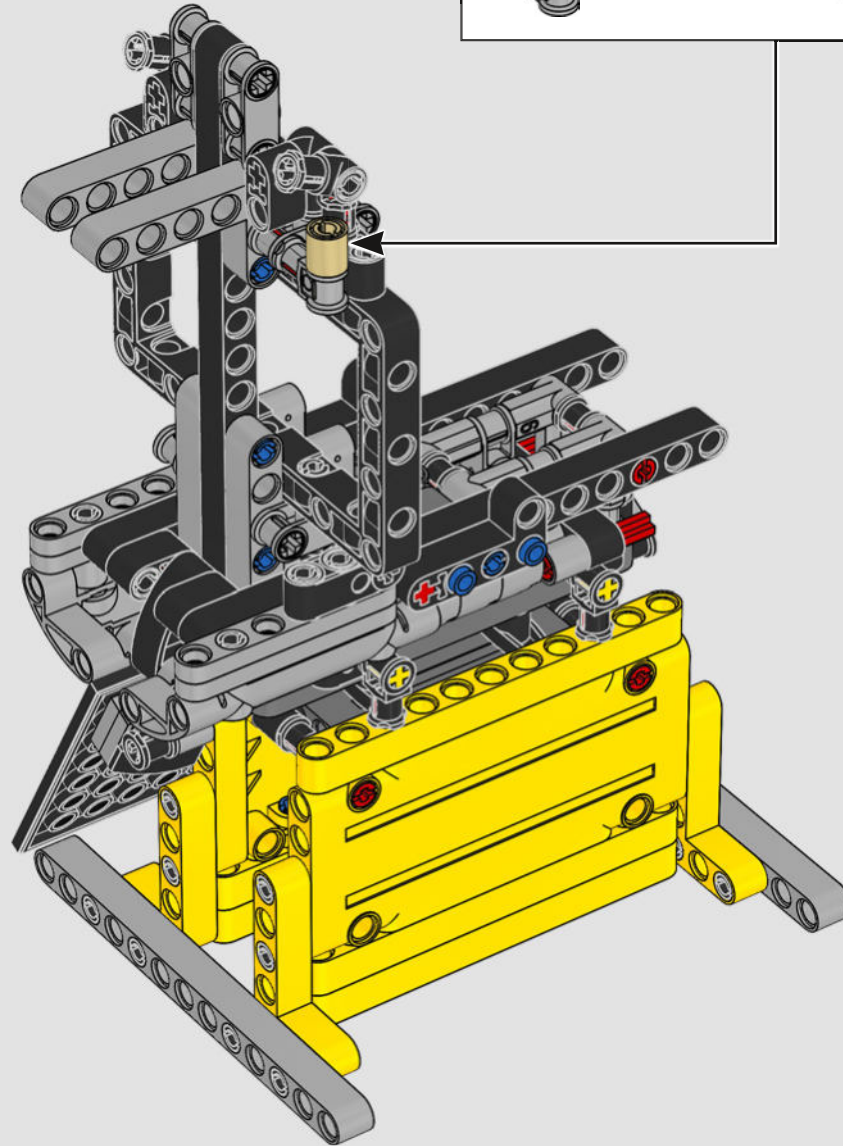
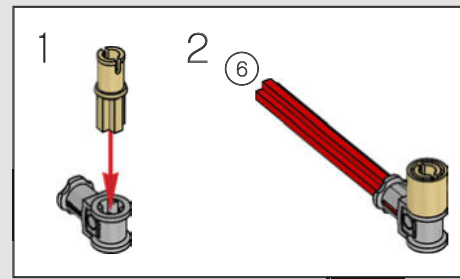
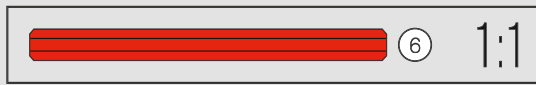

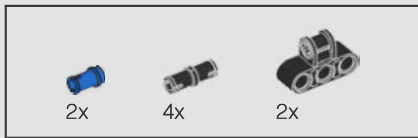

245

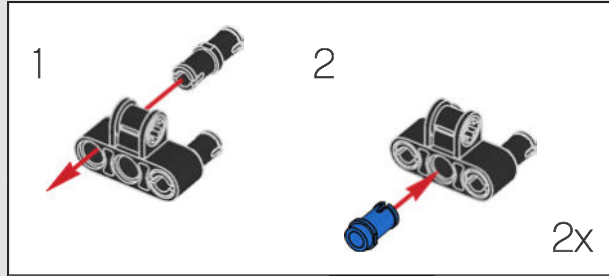
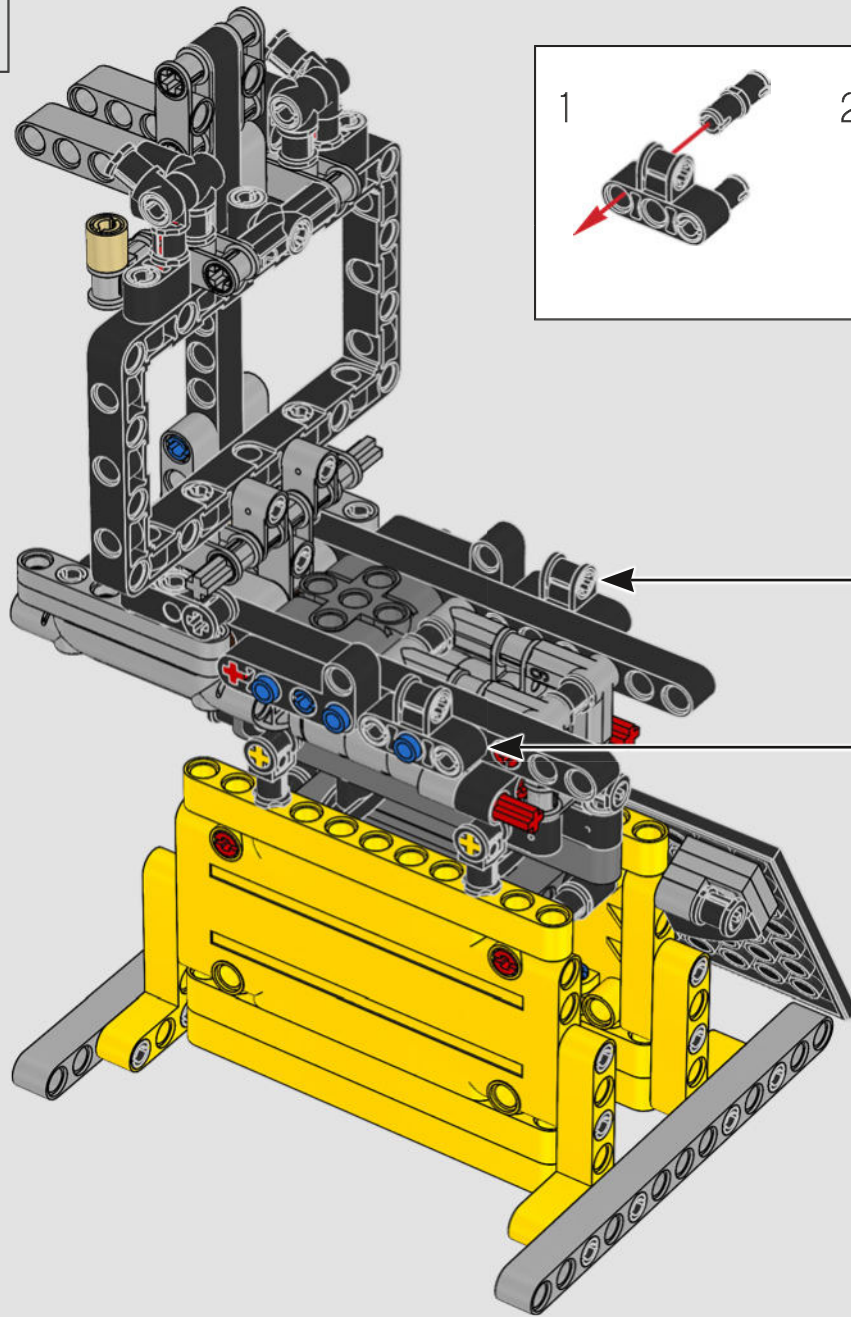

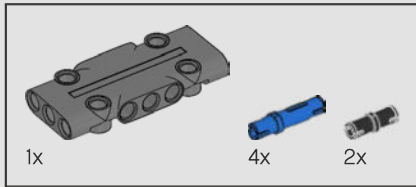
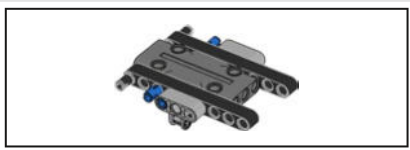

246

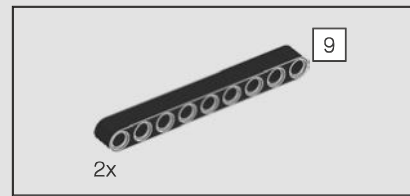
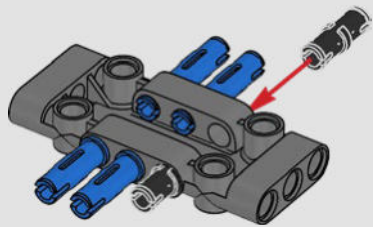

247

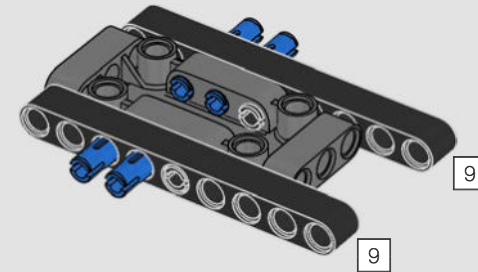

248

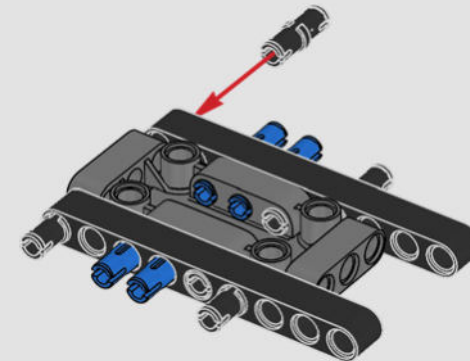

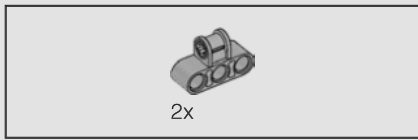

249

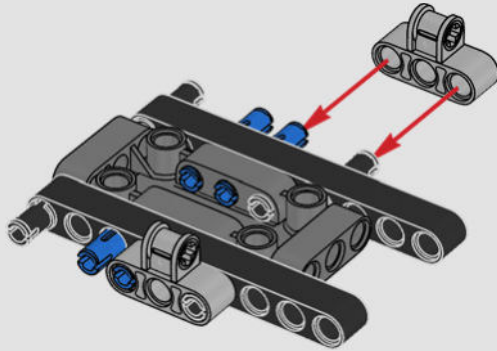

250

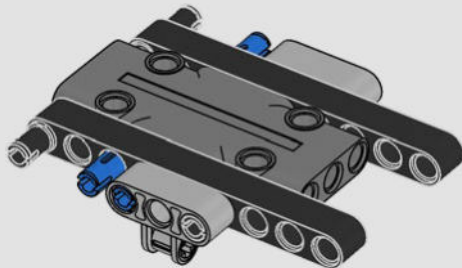

251

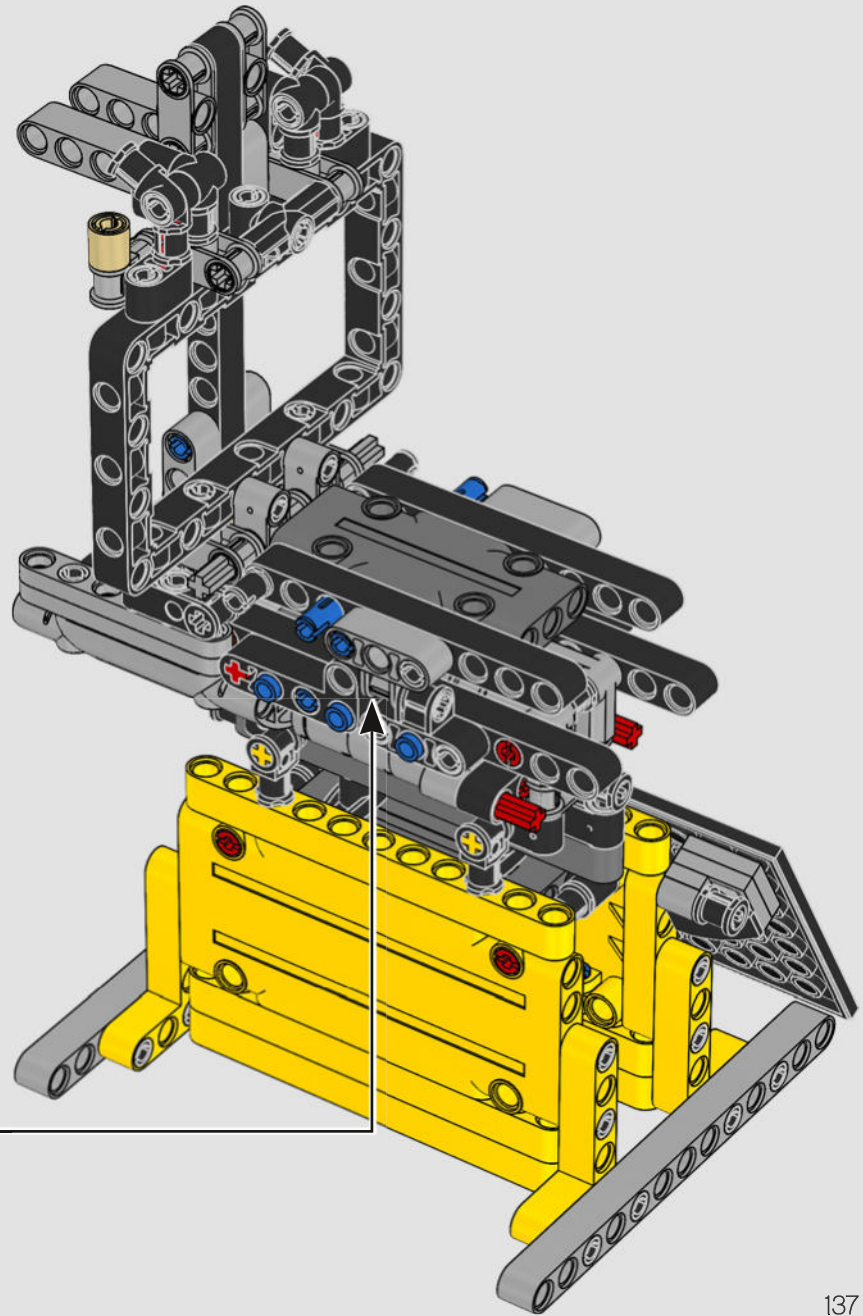

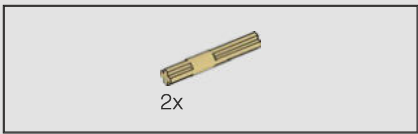

252

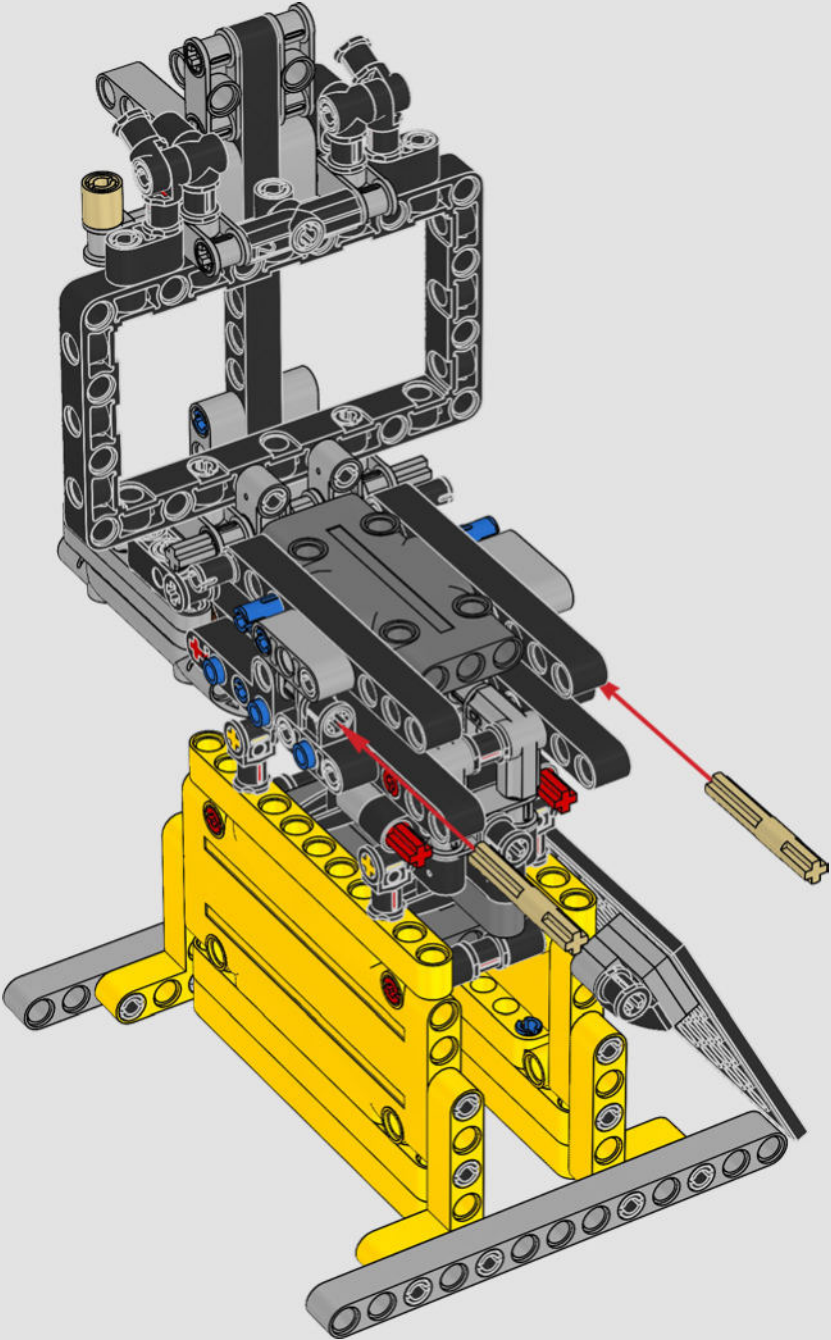

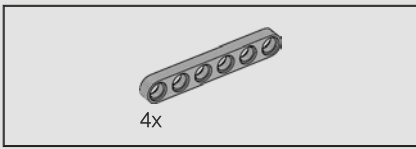

253

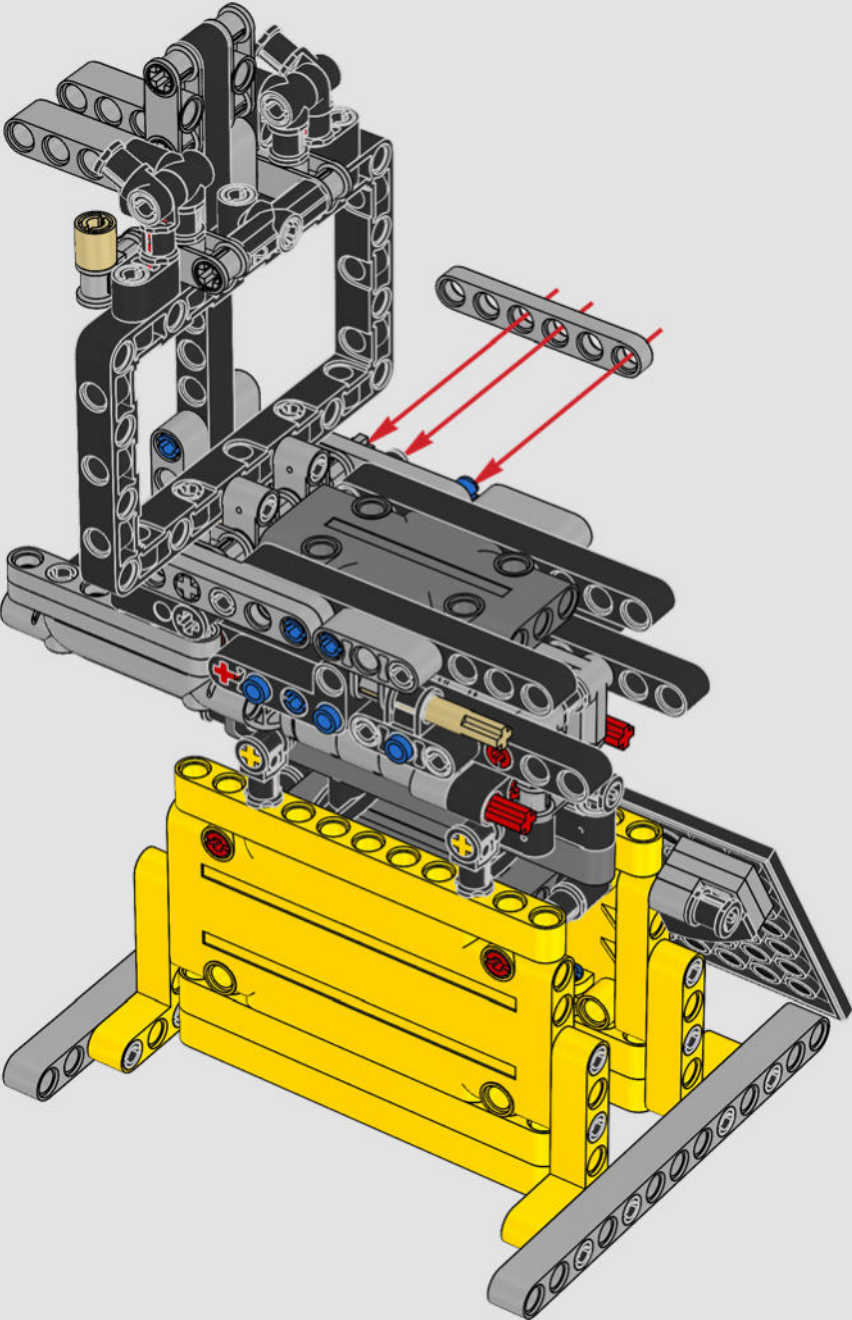

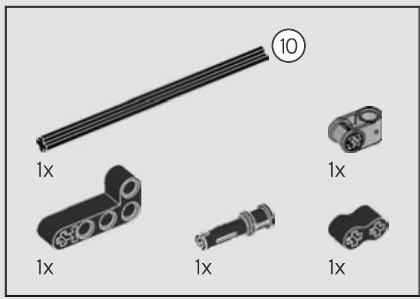

254

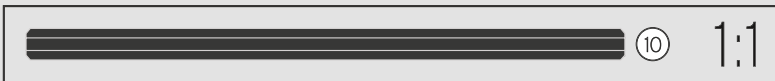
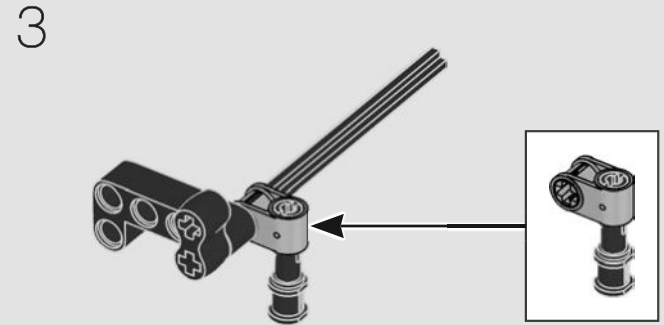
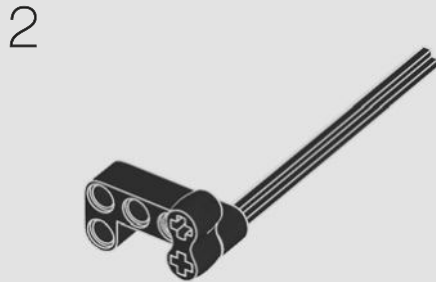
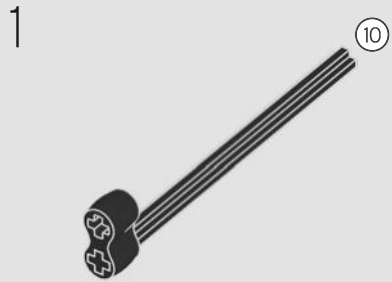

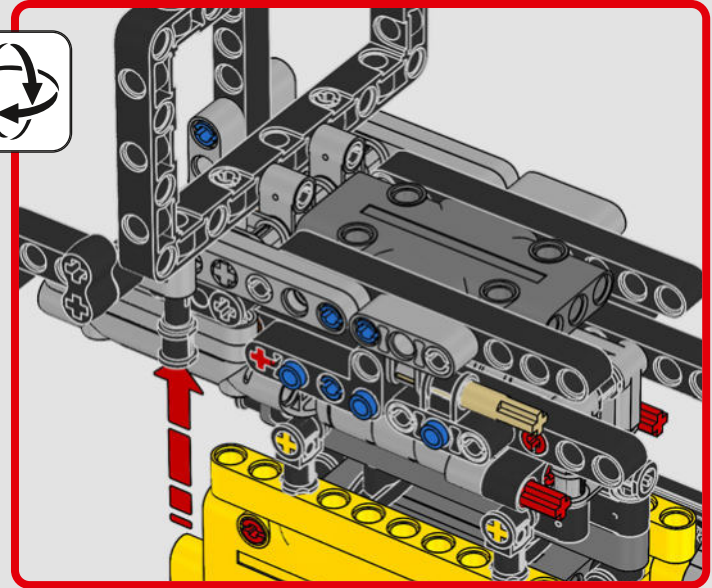
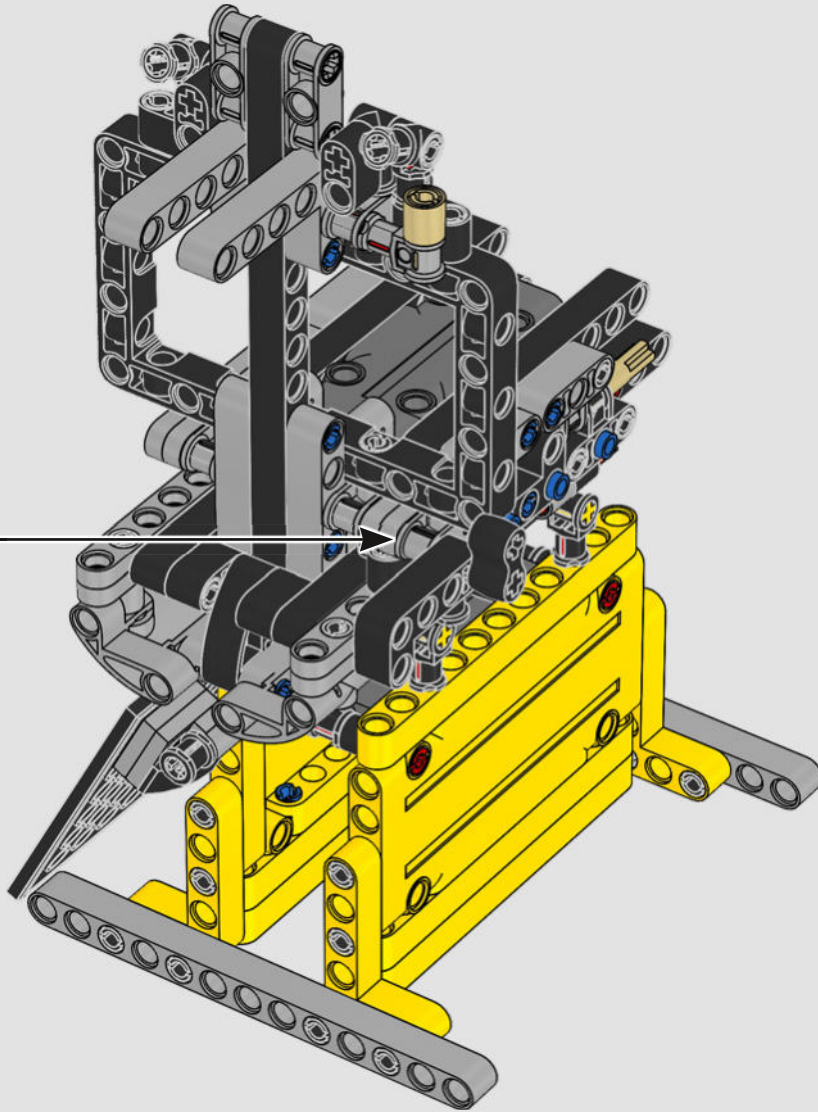

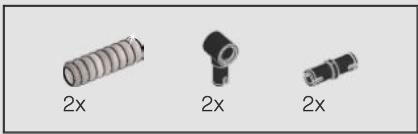

255

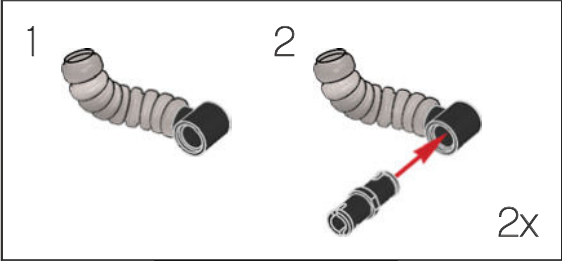
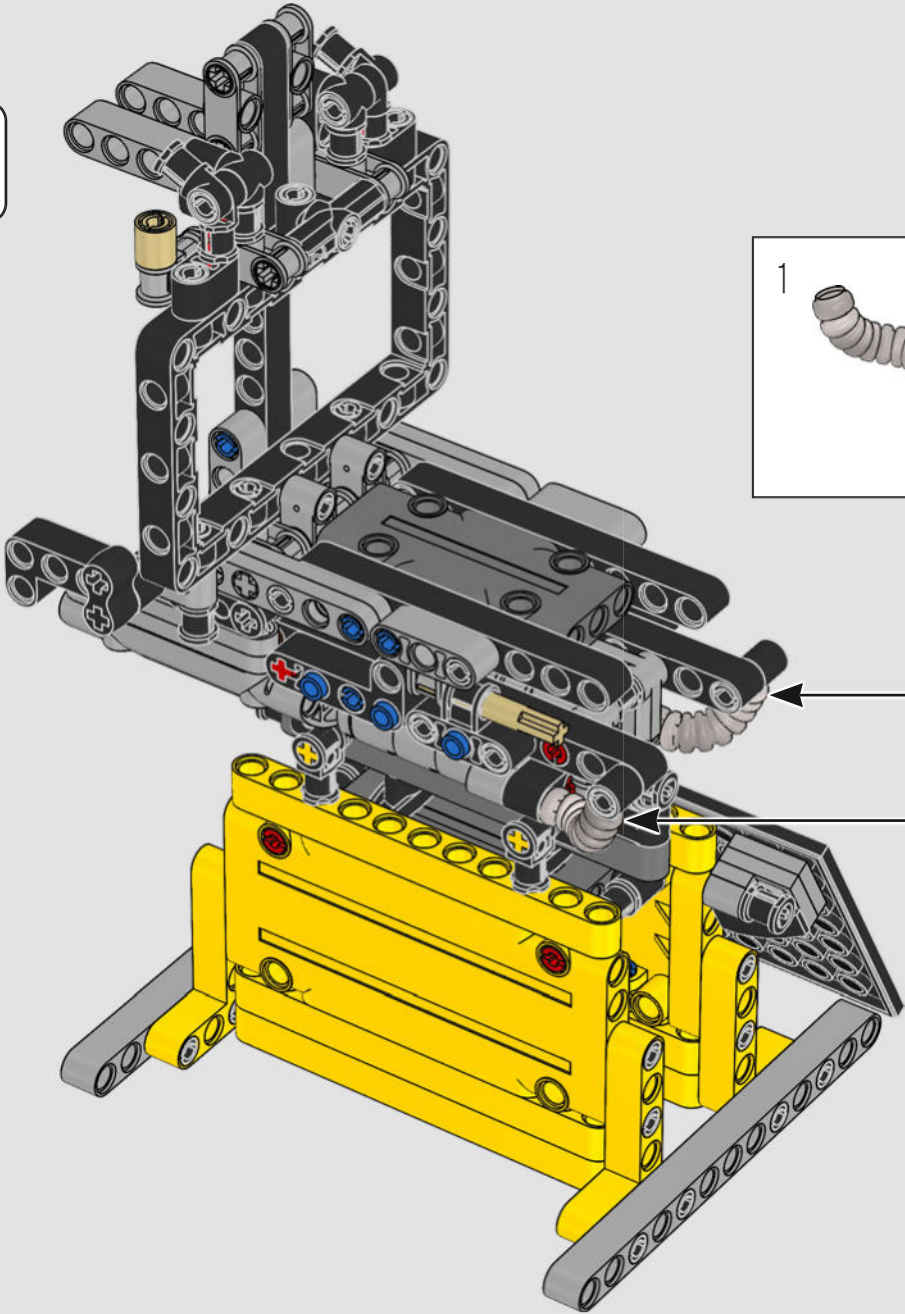

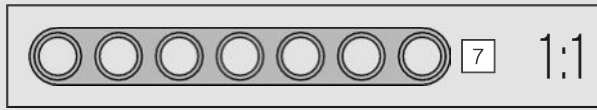
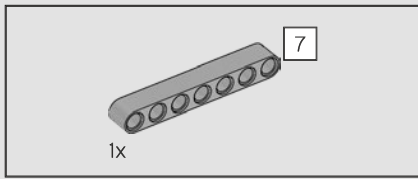

256

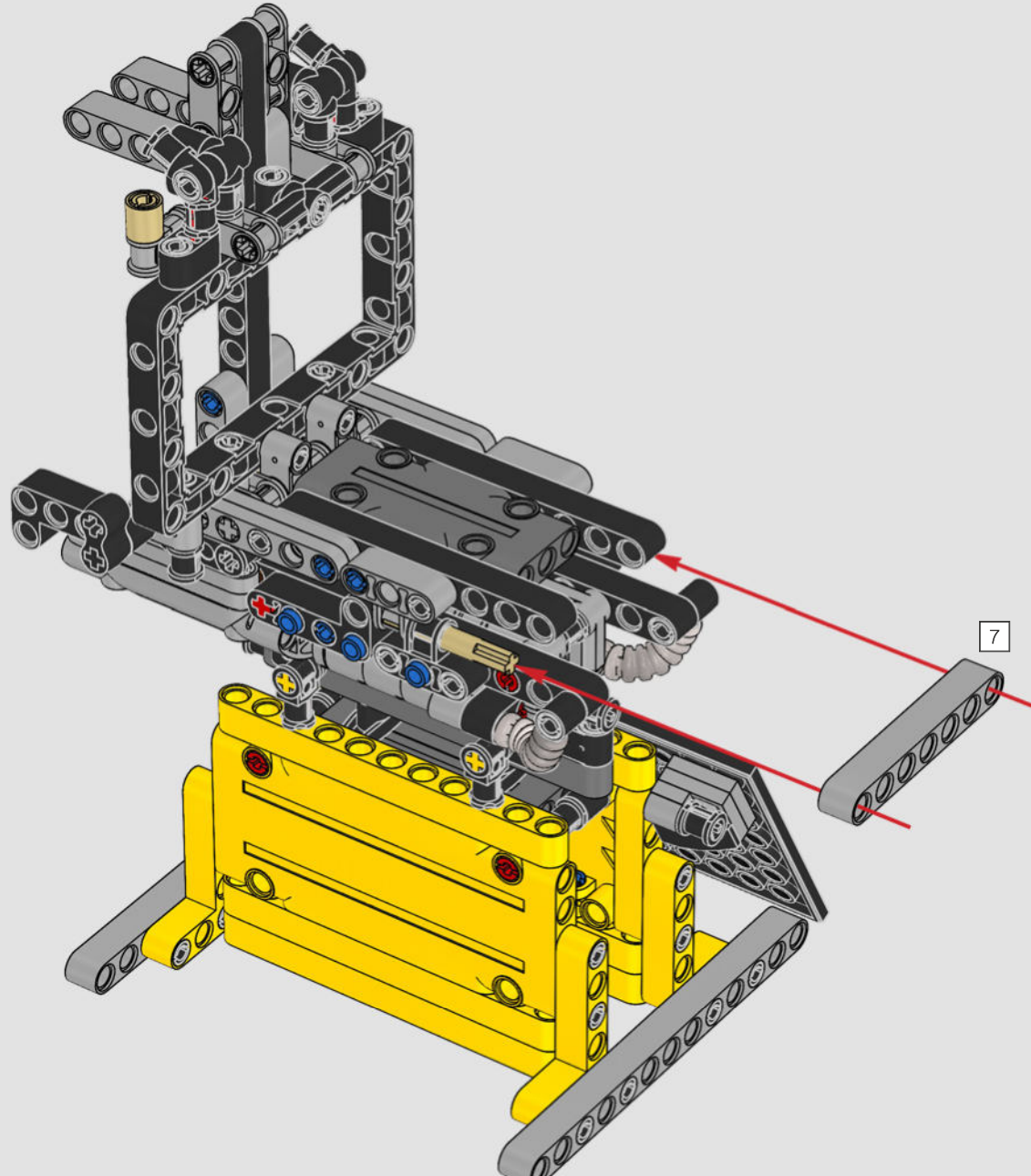

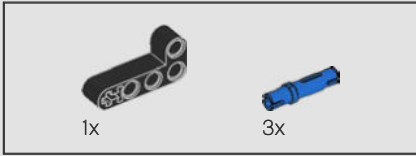
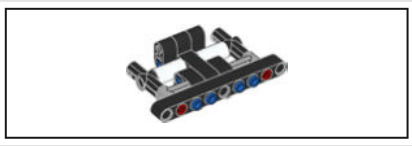

257

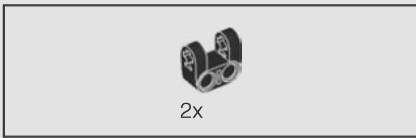
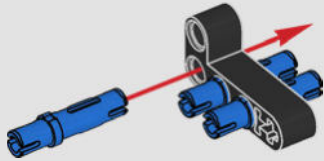

258

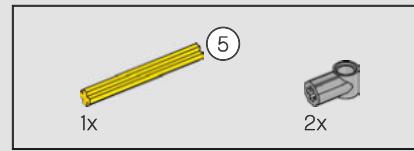
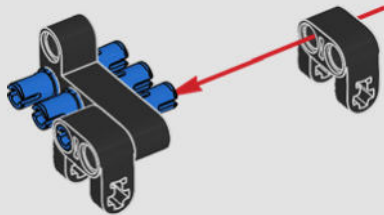

259

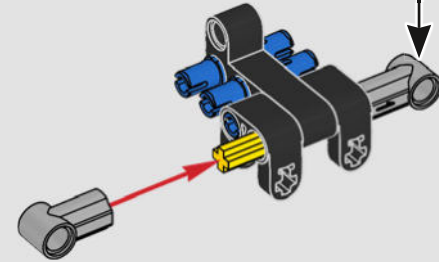
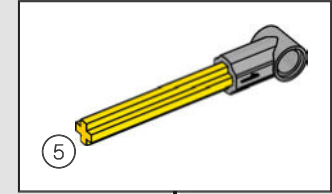

260

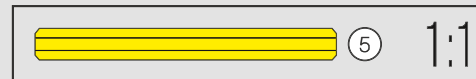
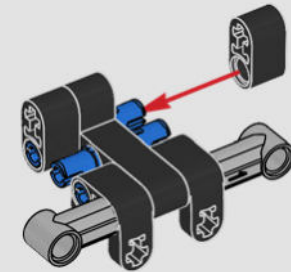



261

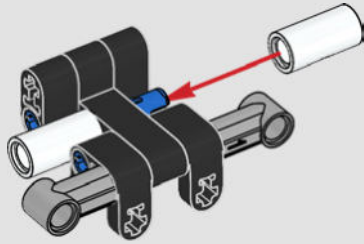

262

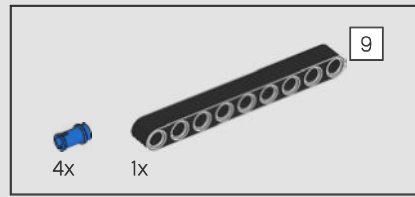
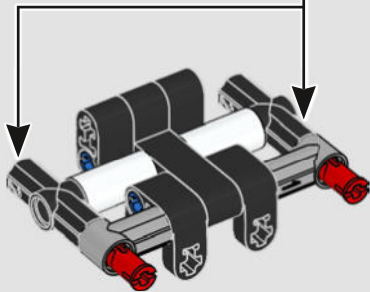
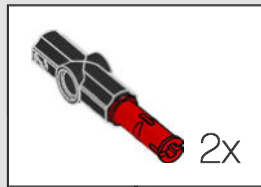

263

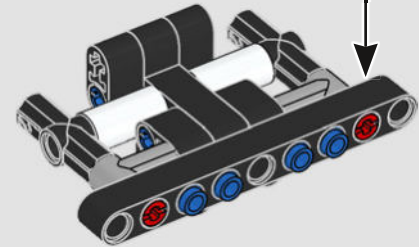
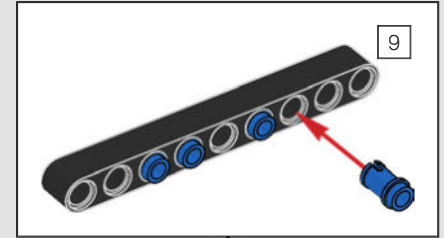

264

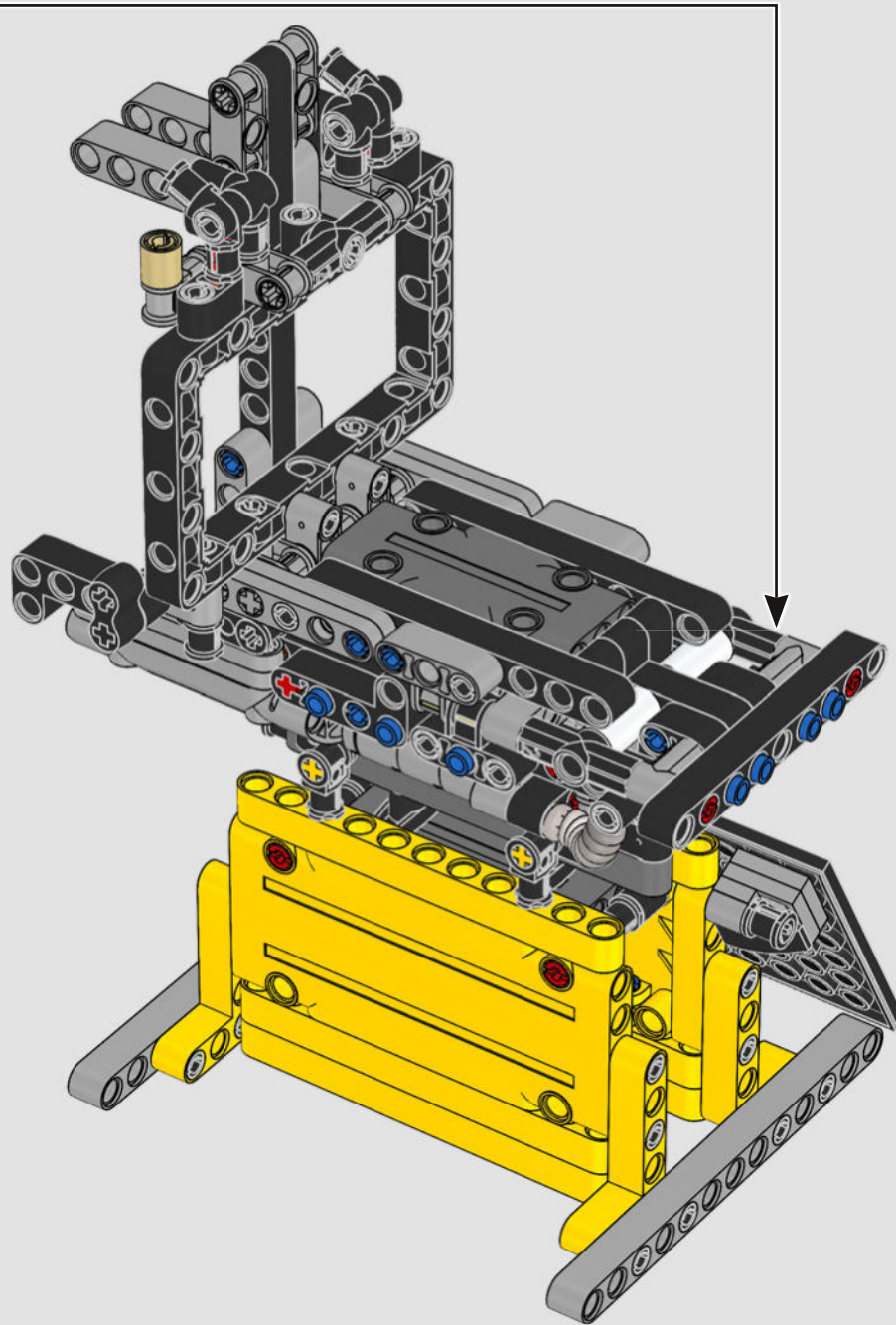

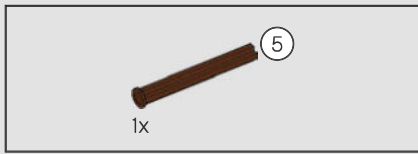

265

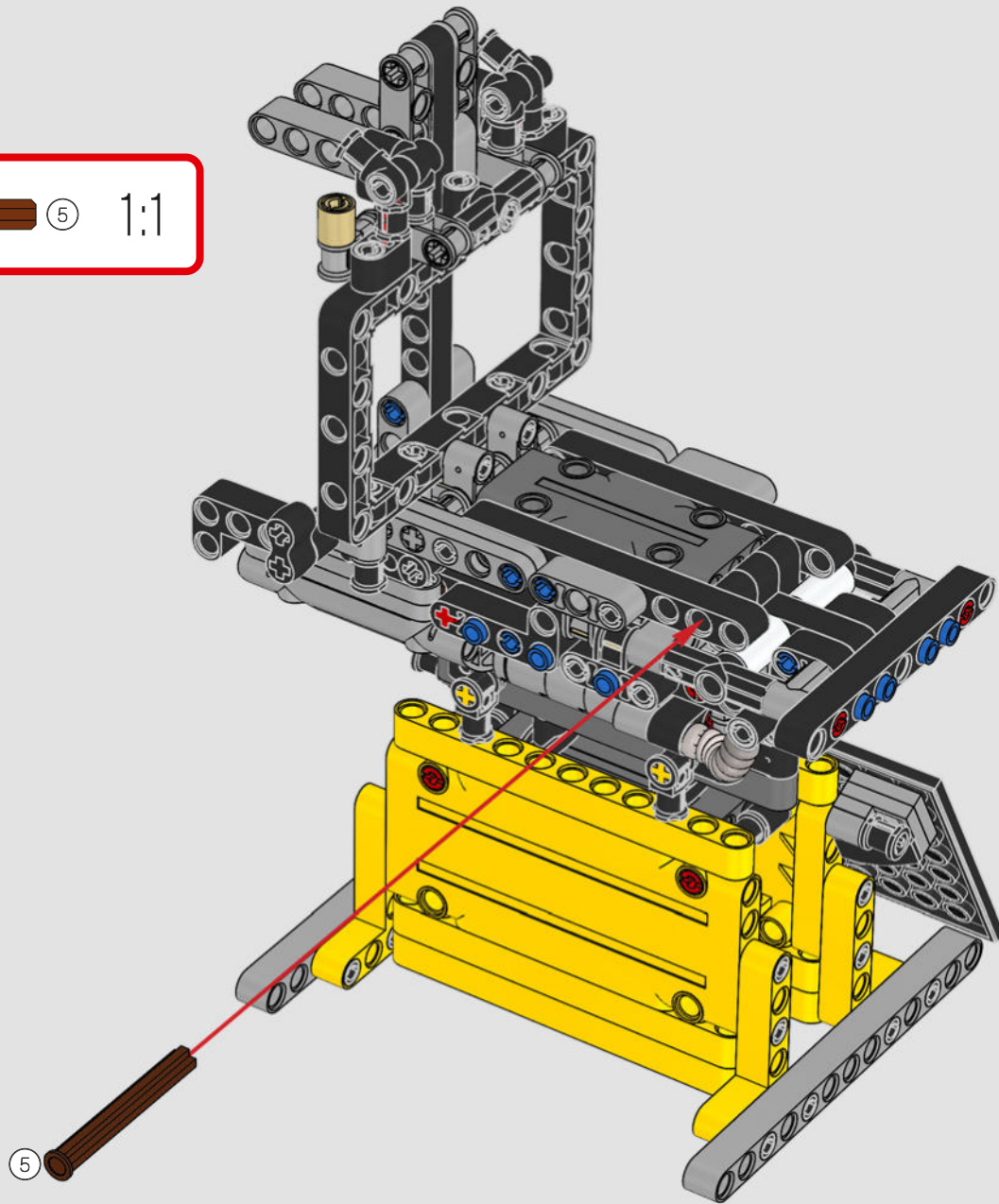
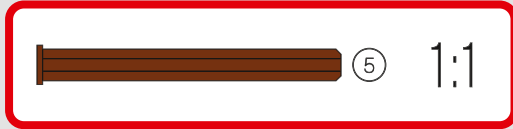

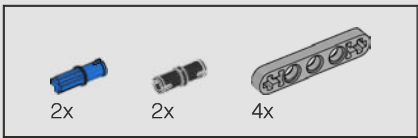

266

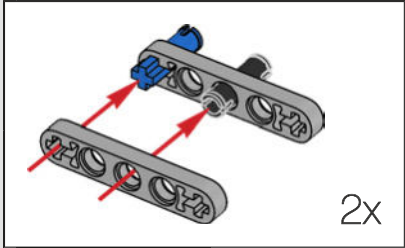
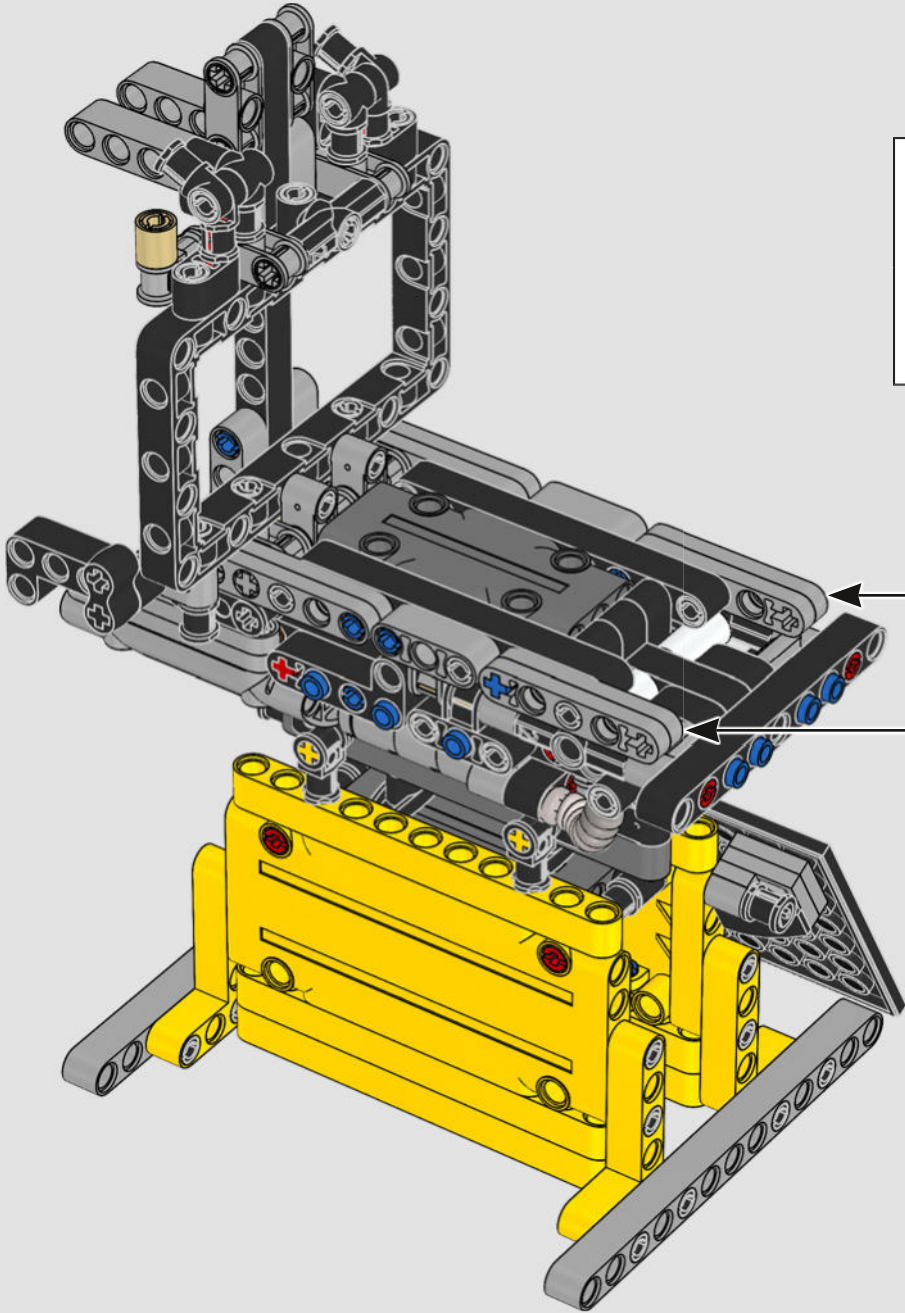

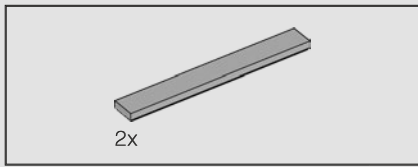



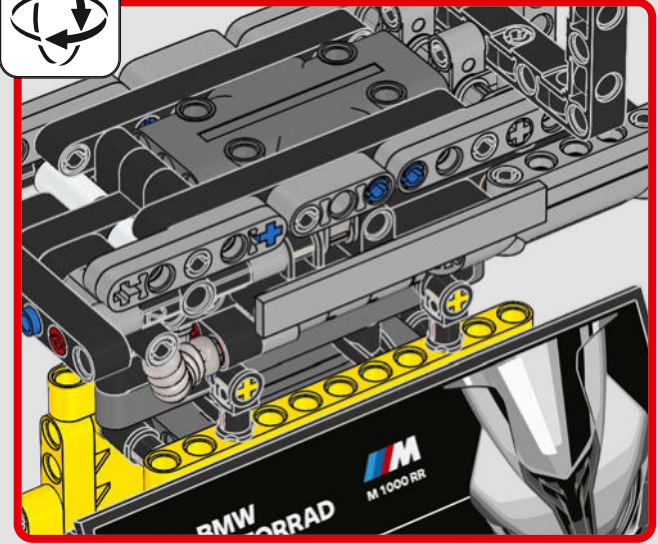
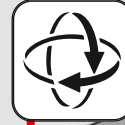
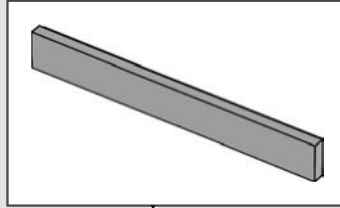
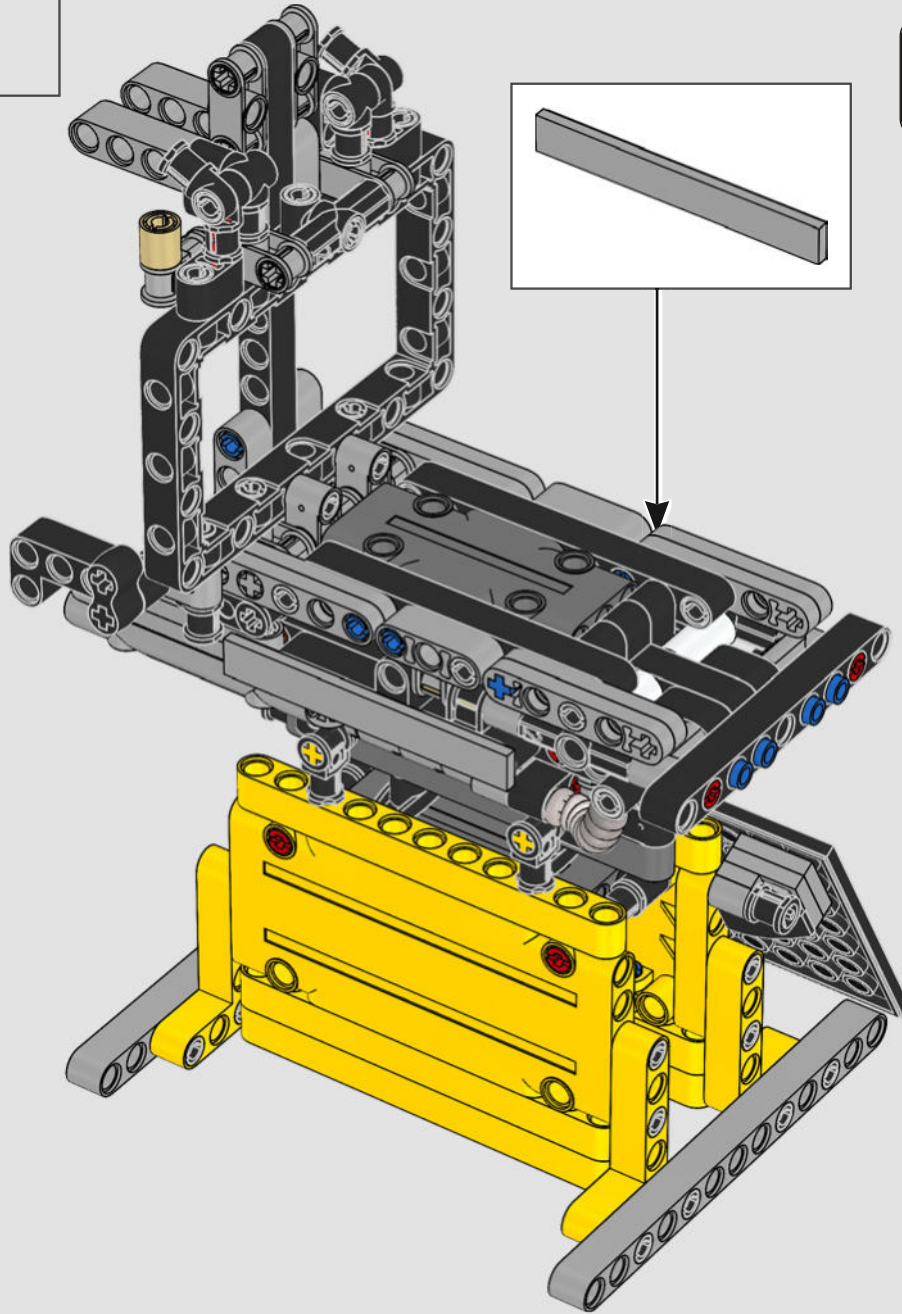

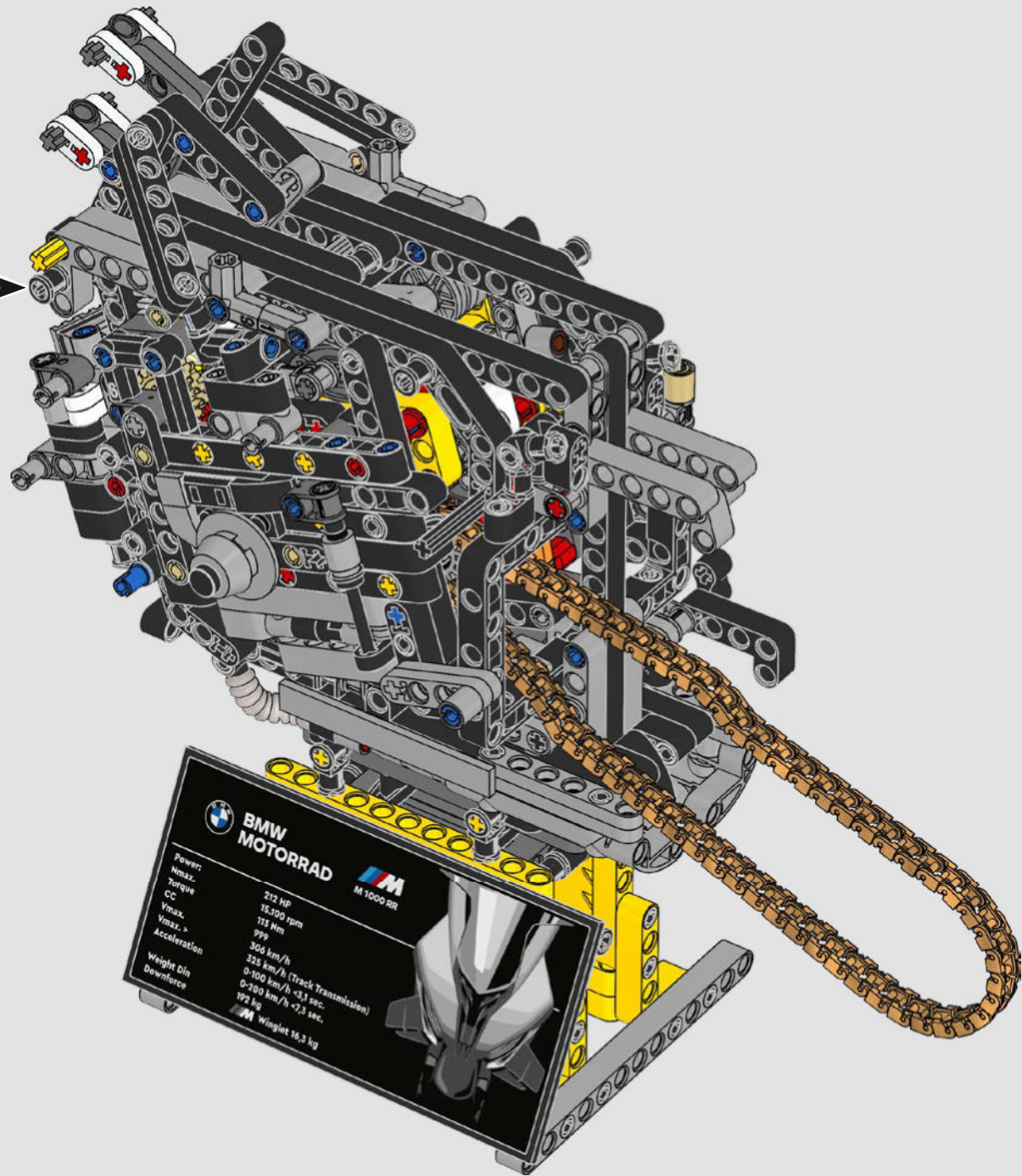
267





 **BMW**
MOTORRAD  M 1000 RR

Power: 212 HP
Nmax. 15,100 rpm
Torque CC
Vmax. 313 km/h
Vmax. > 306 km/h
Acceleration 0-100 km/h (Track Transmission)
Weight Din 225 km/h
Downforce 0-200 km/h < 3.1 sec.
192 kg > 7.3 sec.
 Winglet 16.3 kg



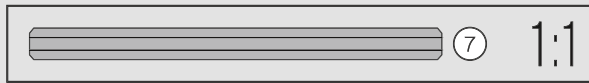
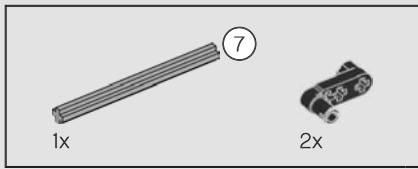

269

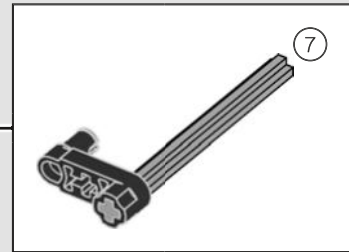
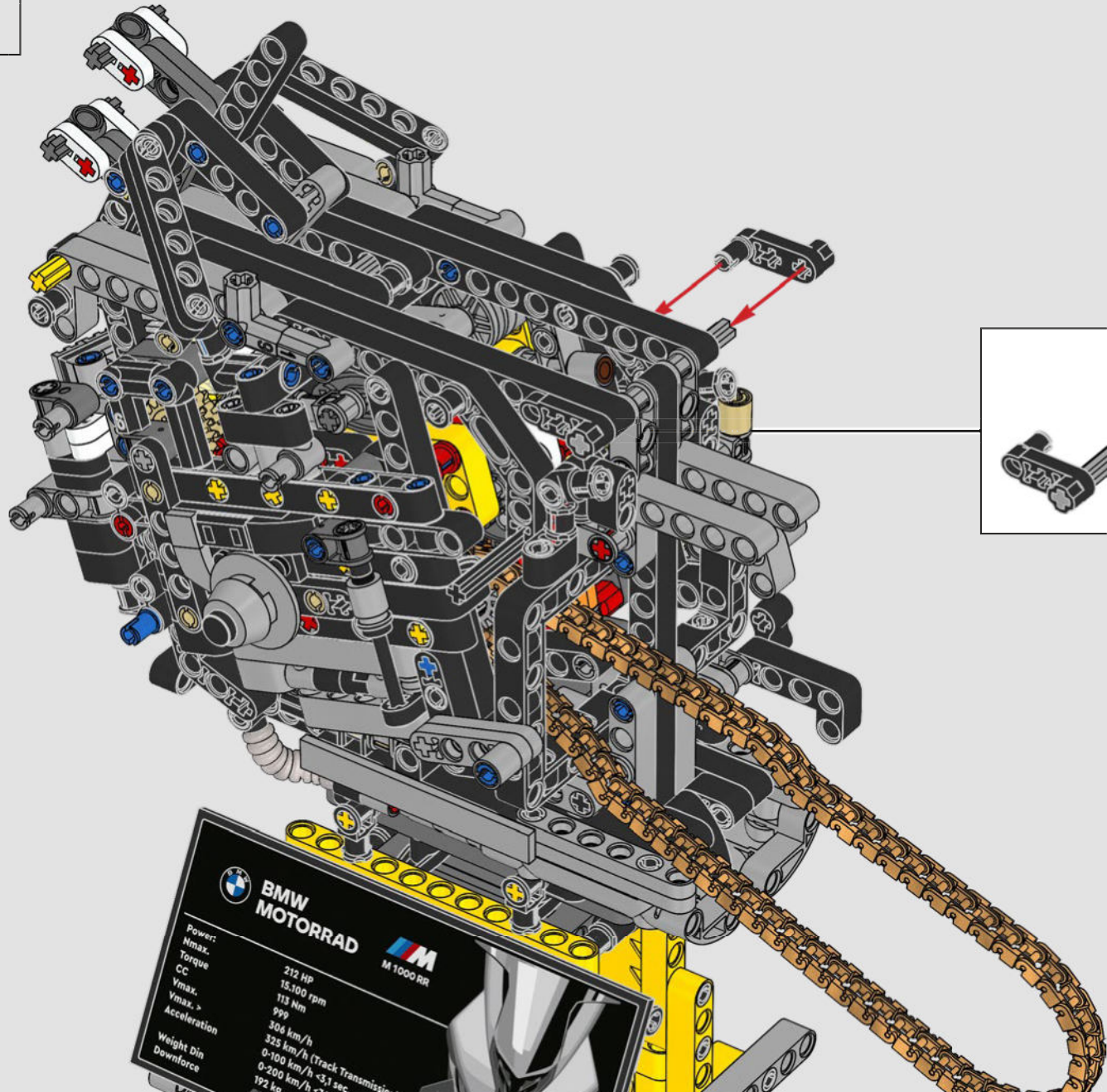



BMW MOTORRAD		M 1000 RR	
Power:		212 HP	
Hmax:		15.100 rpm	
Torque		113 Nm	
CC		999	
Vmax:		306 km/h	
Vmax. >		325 km/h (Track Transmission)	
Acceleration		0-100 km/h < 3.1 sec	
Weight Din		0-200 km/h < 3.1 sec	
Downforce		192 kg	

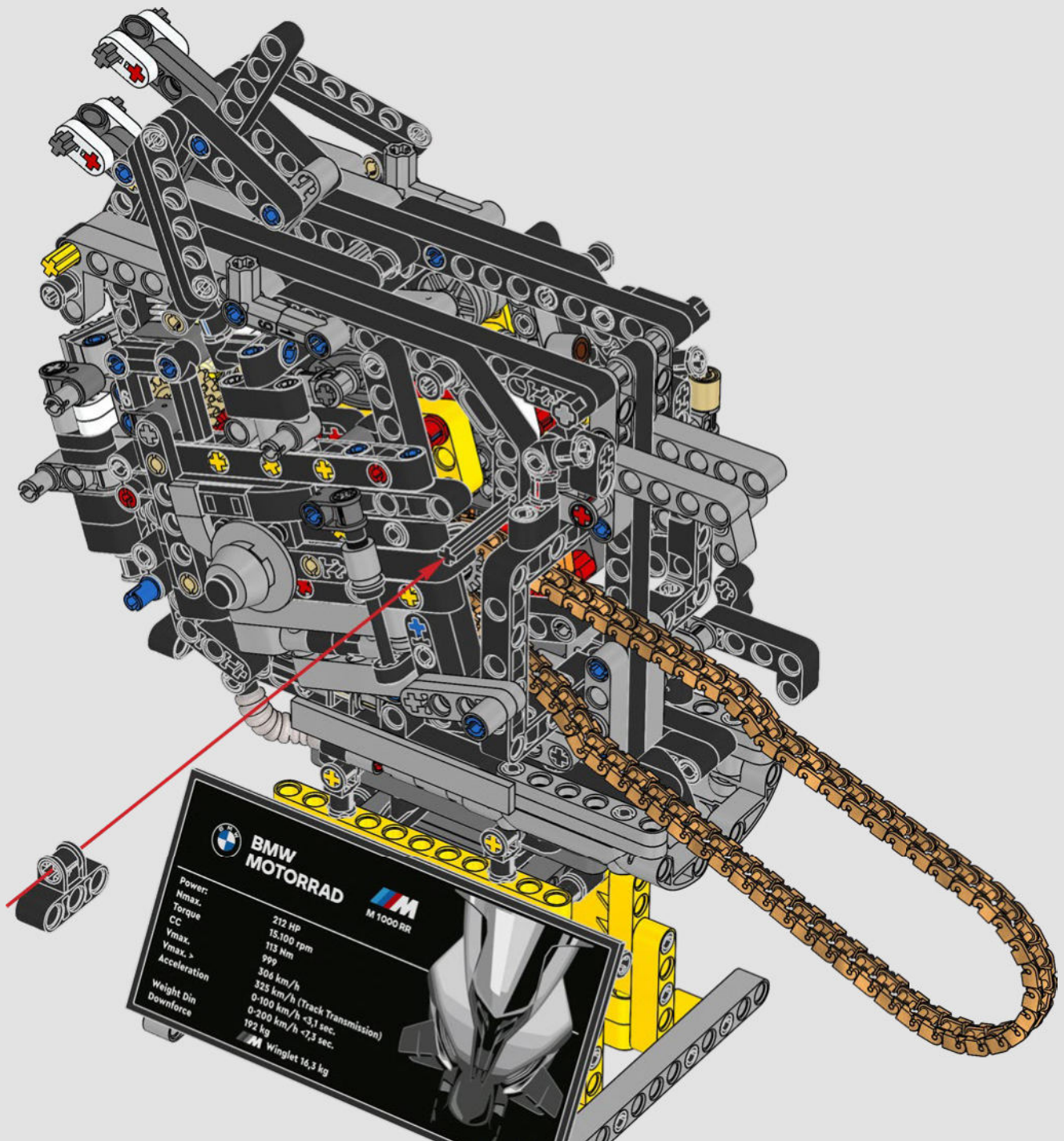

270



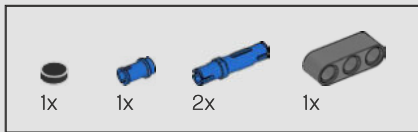

BMW MOTORRAD  **M 1000 RR**

Power:	212 HP
Hmax:	15-100 rpm
Torque	113 Nm
CC	999
Vmax:	306 km/h
Vmax. >	328 km/h (Track Transmission)
Acceleration	0-100 km/h <3,1 sec.
Weight Din	0-200 km/h <7,3 sec.
Downforce	192 kg
	 Winglet 16,3 kg

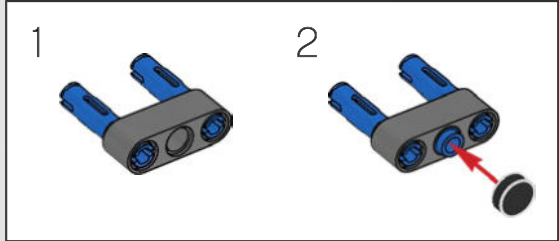
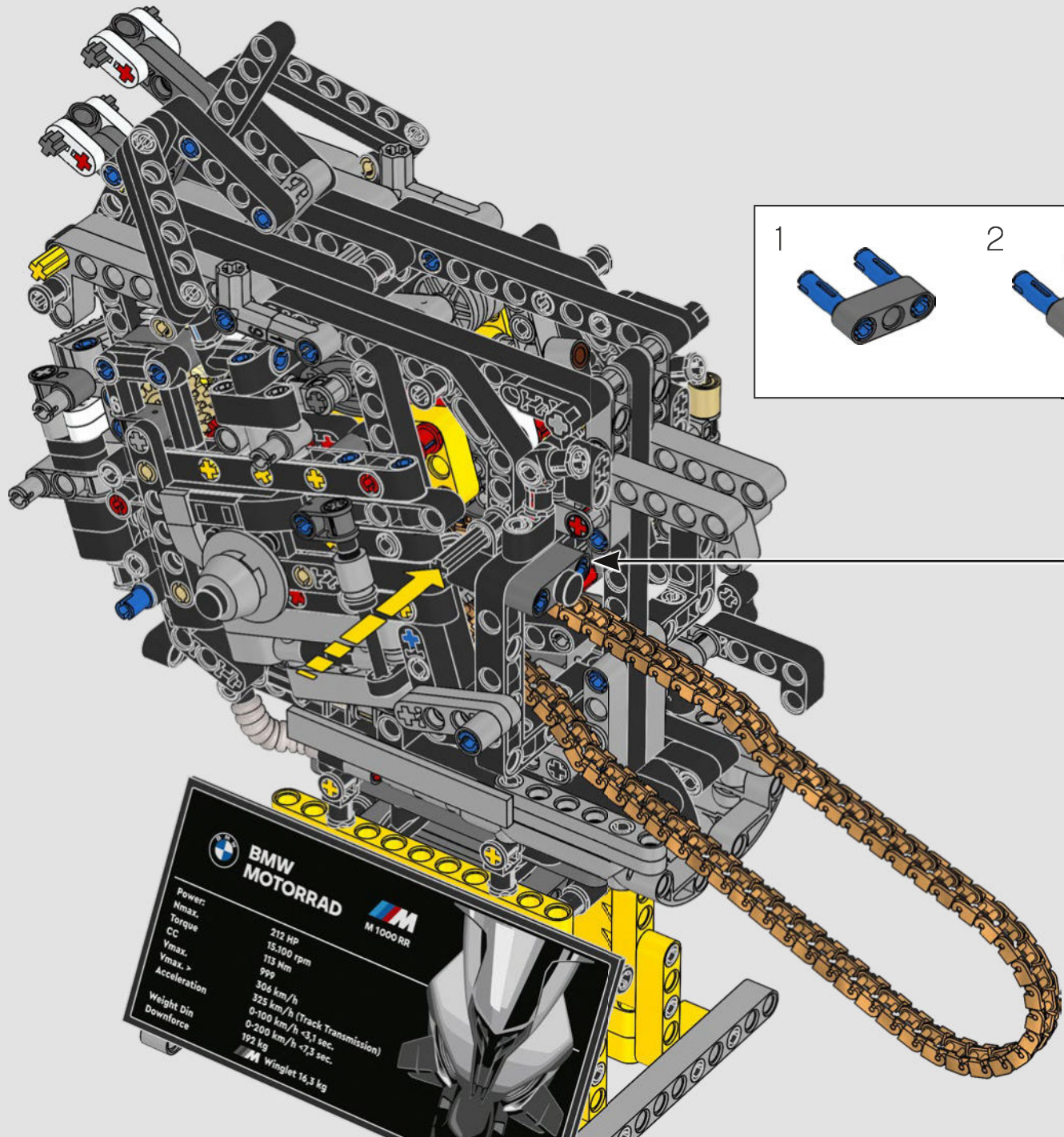

271



BMW MOTORRAD  

Power:	212 HP
Nmax:	15.100 rpm
Torque	113 Nm
CC	999
Ymax:	306 km/h
Ymax. >	325 km/h (Track Transmission)
Acceleration	0-100 km/h < 3,1 sec.
Weight Din	192 kg
Downforce	192 kg

Winglet 16,3 kg



272

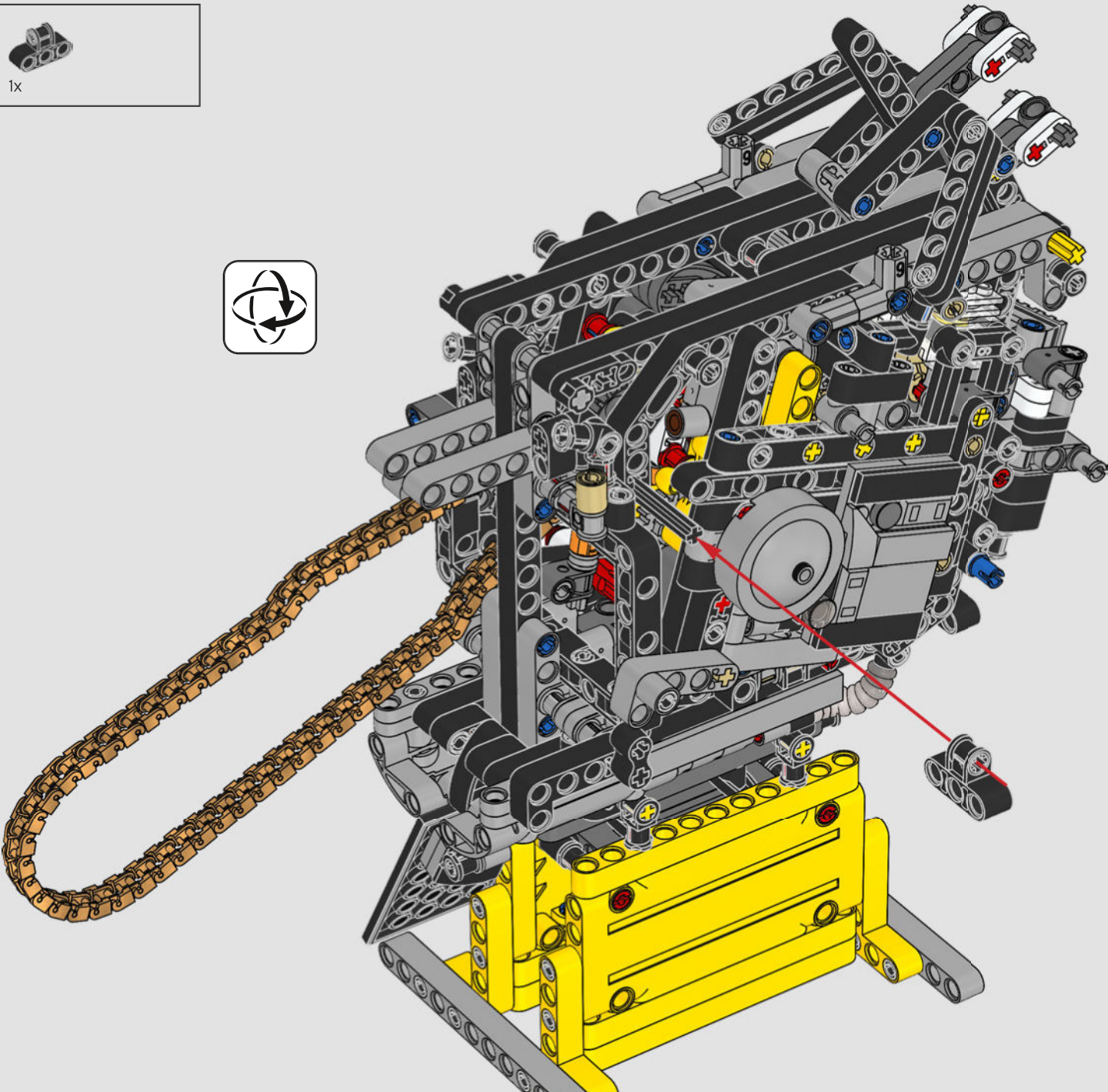

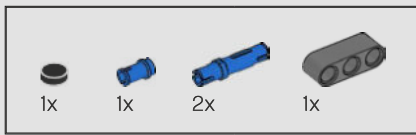

273

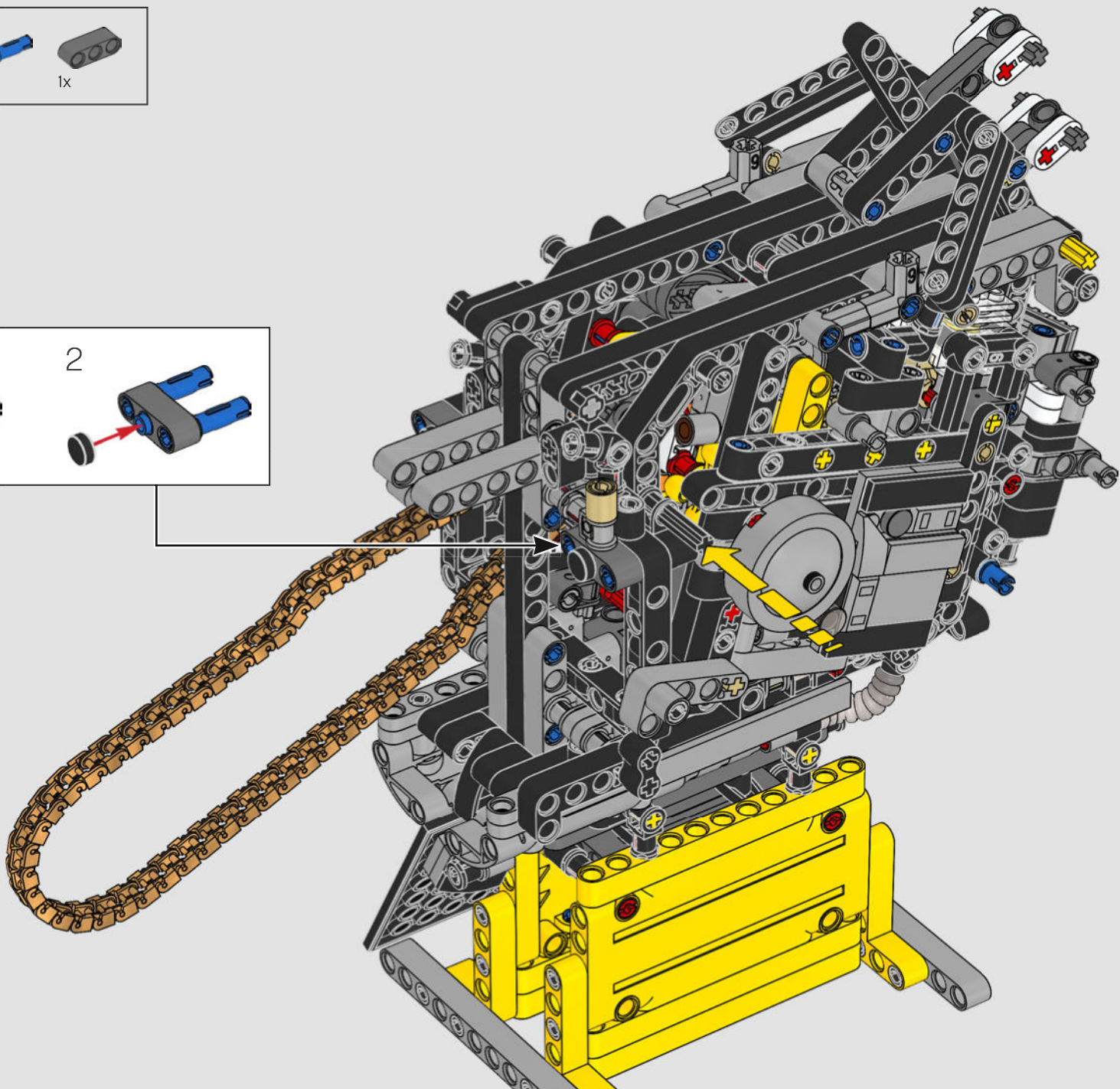
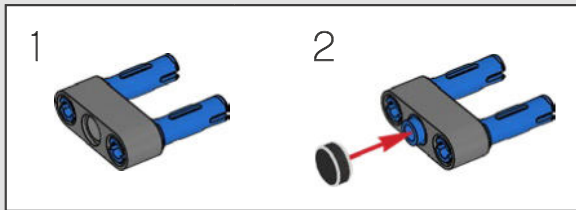

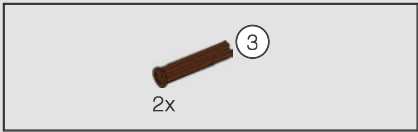

274

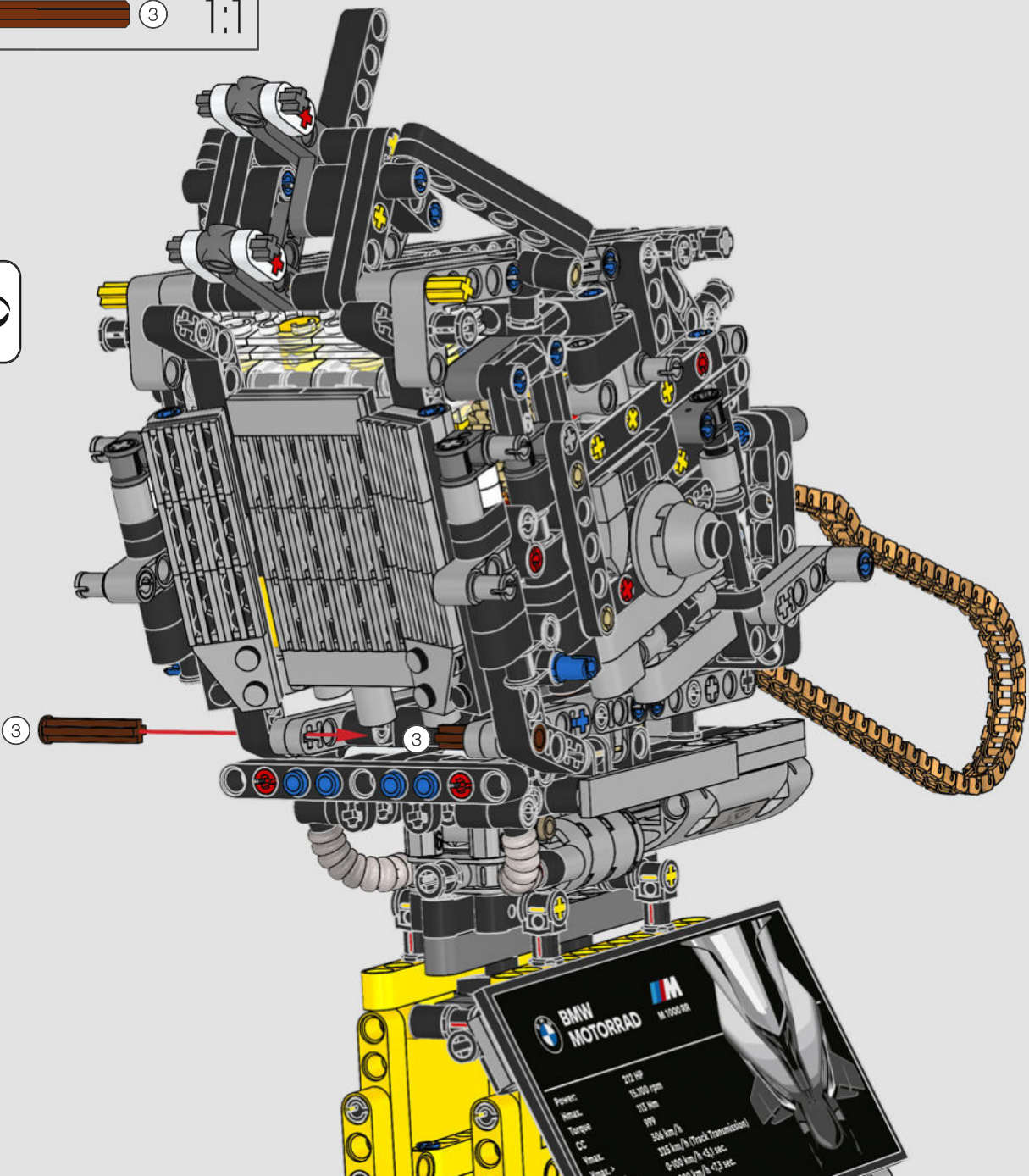



2x



3x



2x

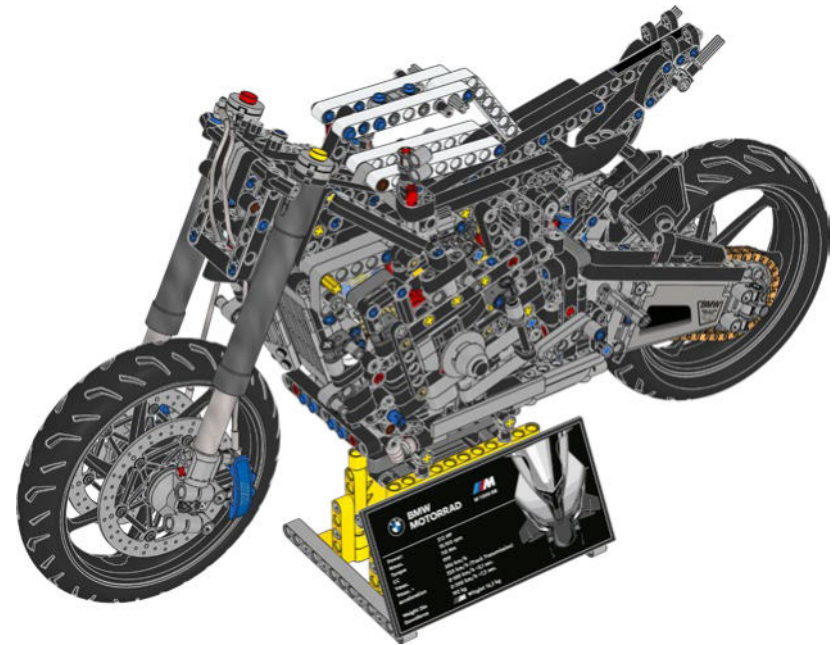
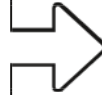



2x

275



2x

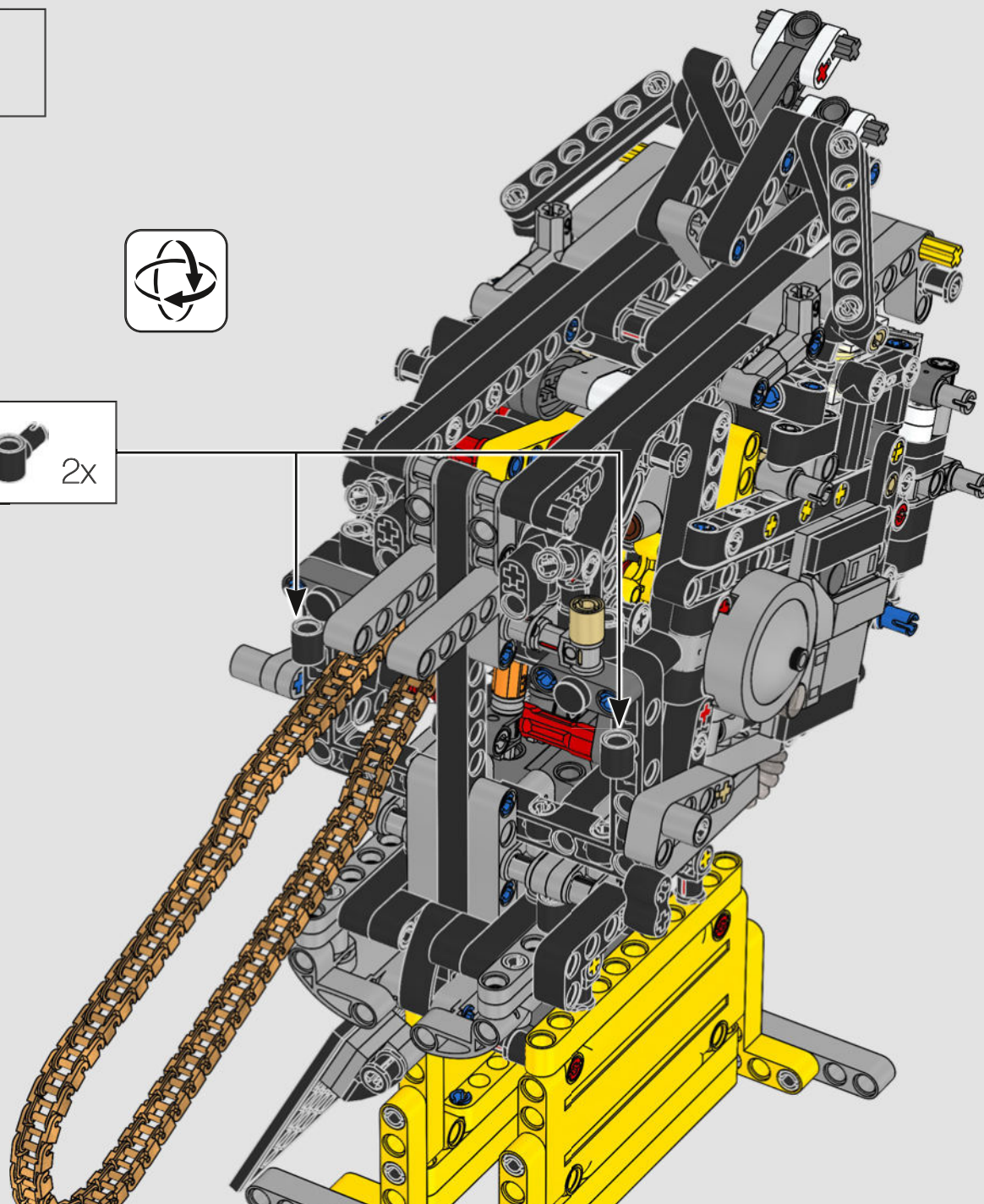

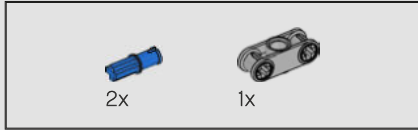
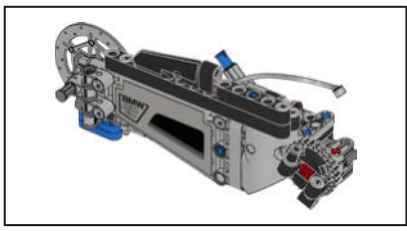

2x

1x

276

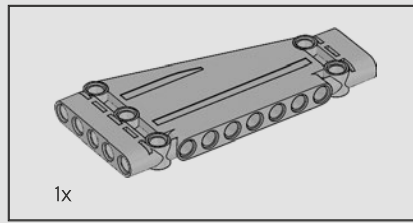
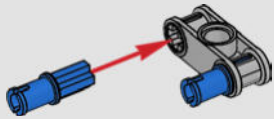

1x

277

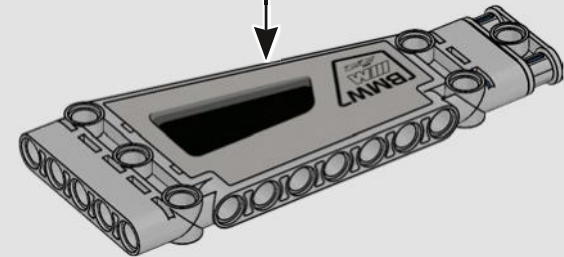
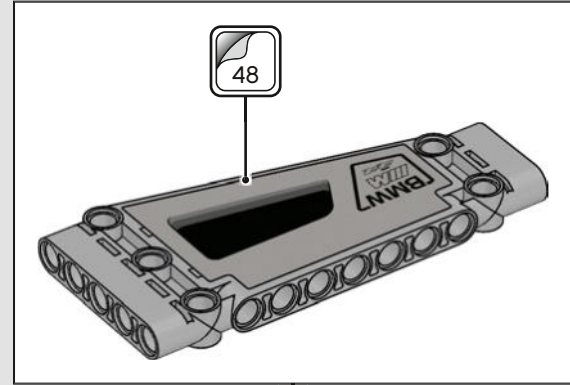

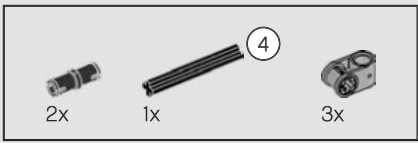

278

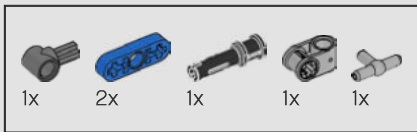
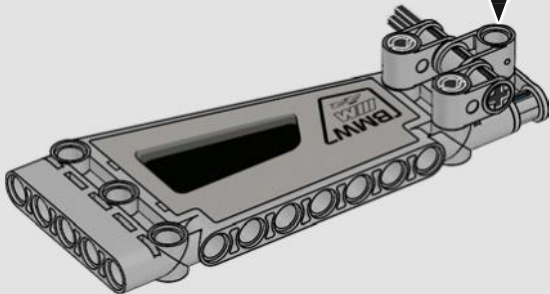
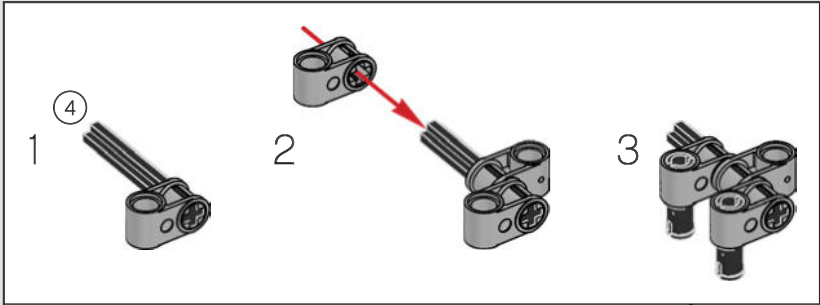

279

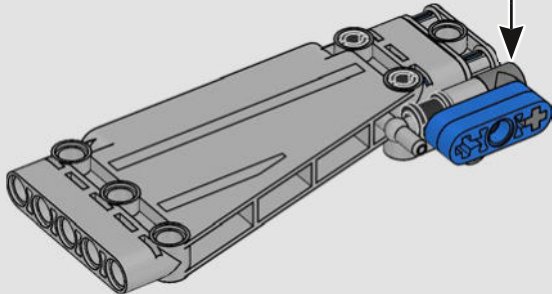
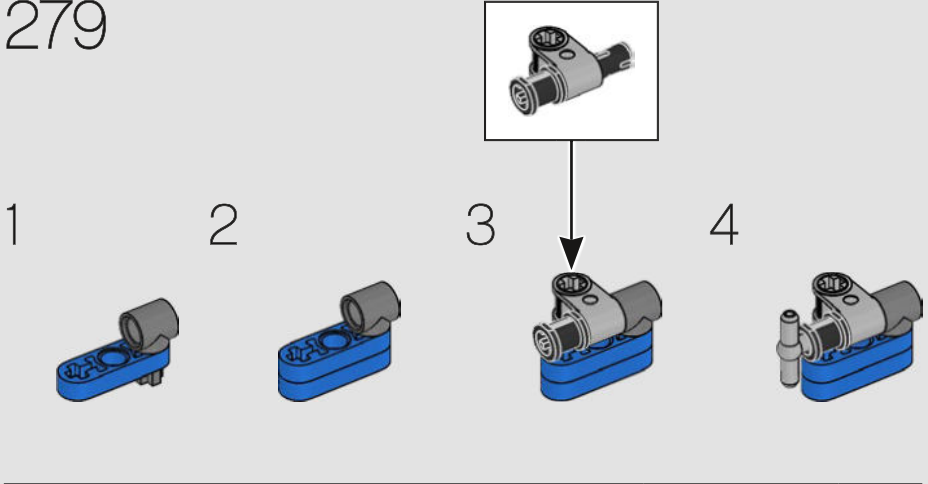

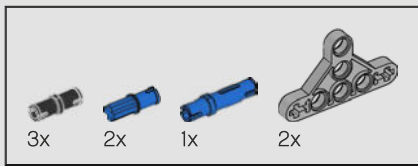

280

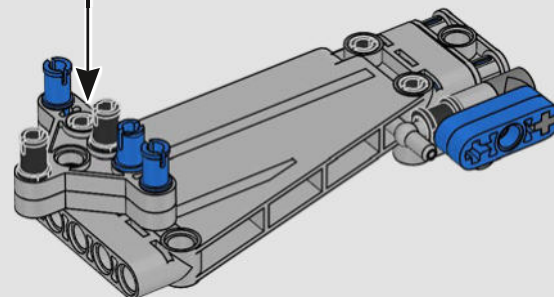
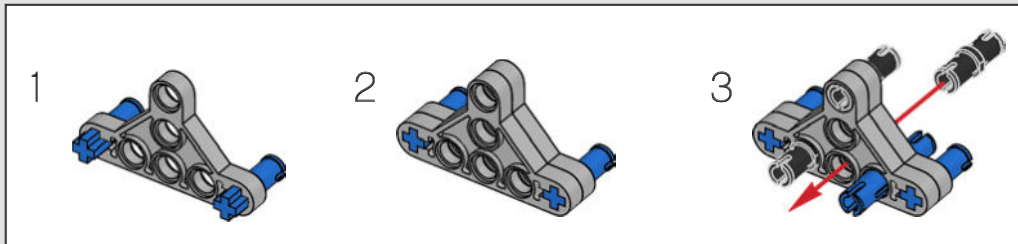

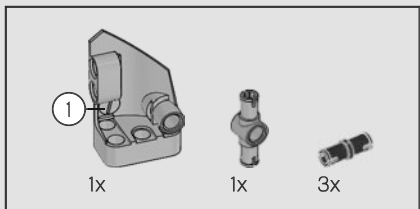

281

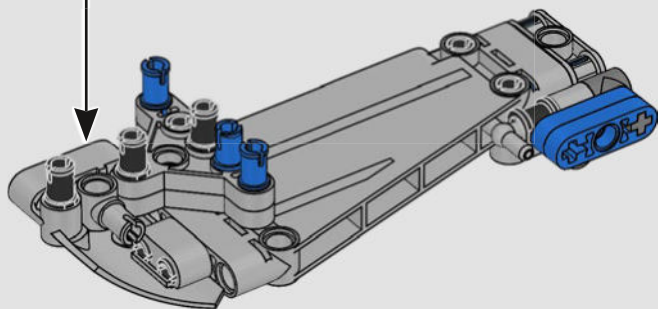
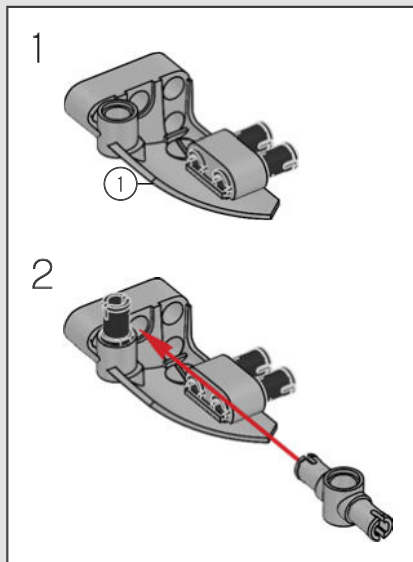

282

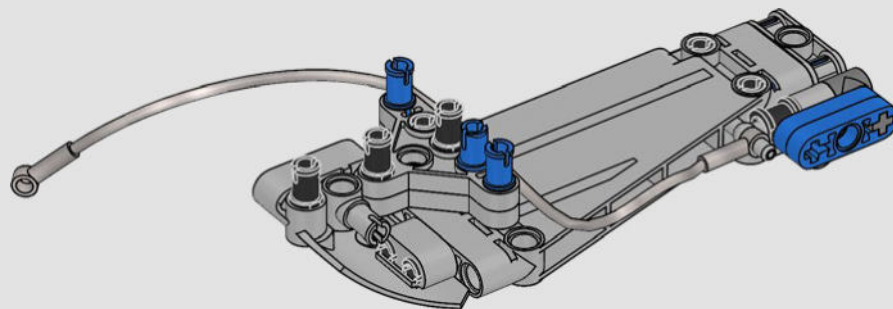

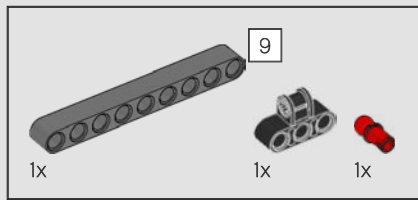

283

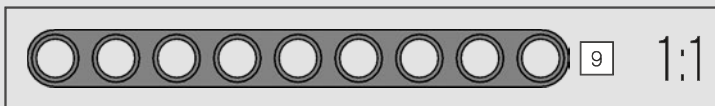
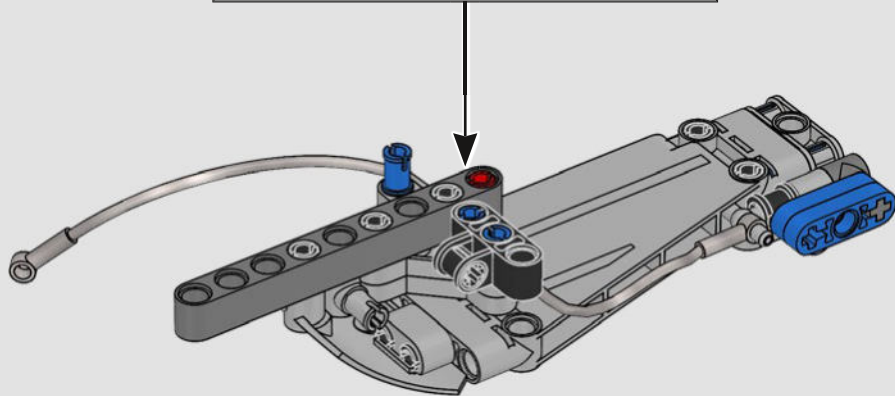
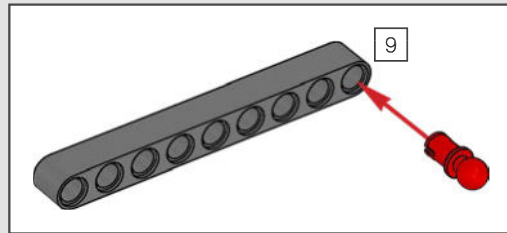
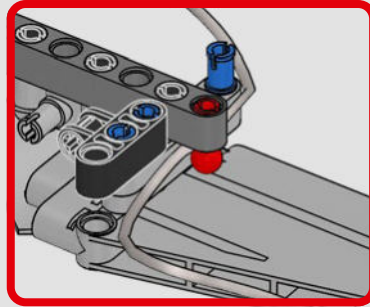

284

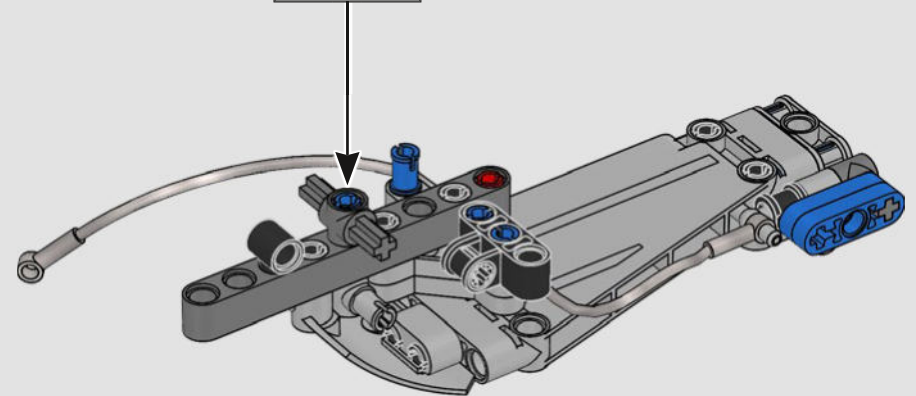
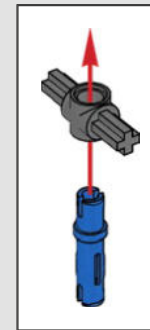

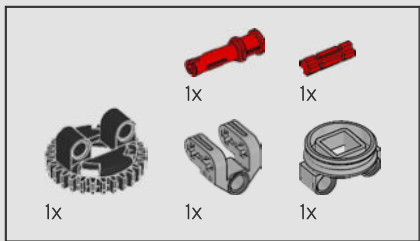

285

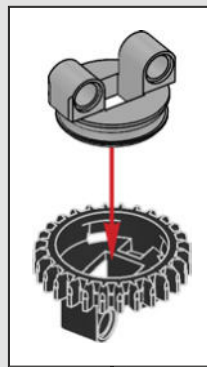

1

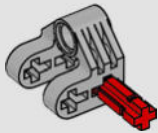

2

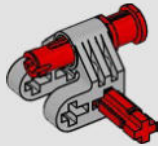

3

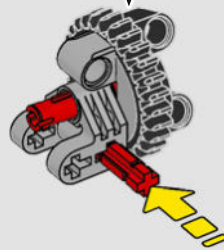

4

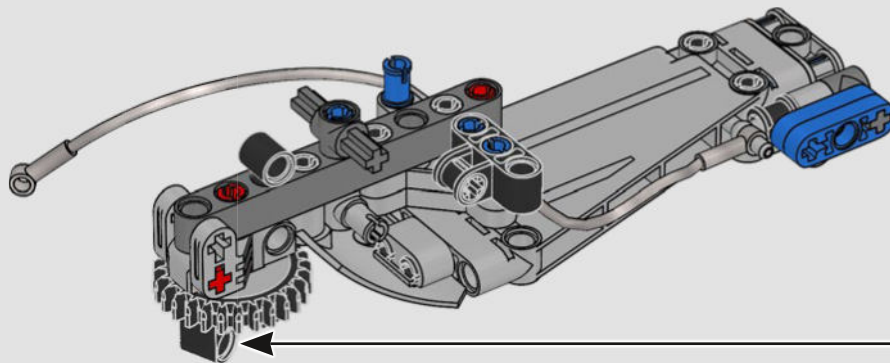

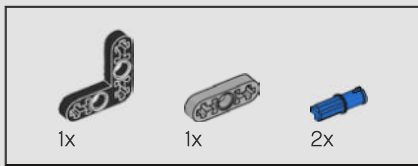

286

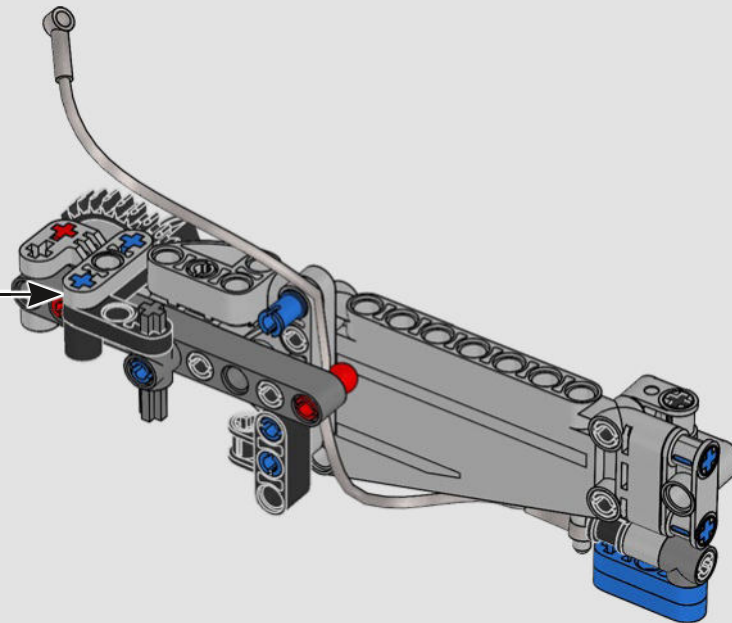
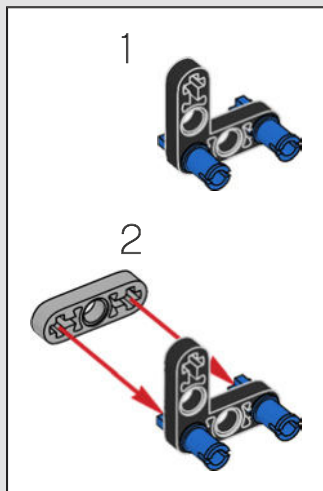



287

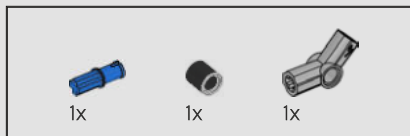
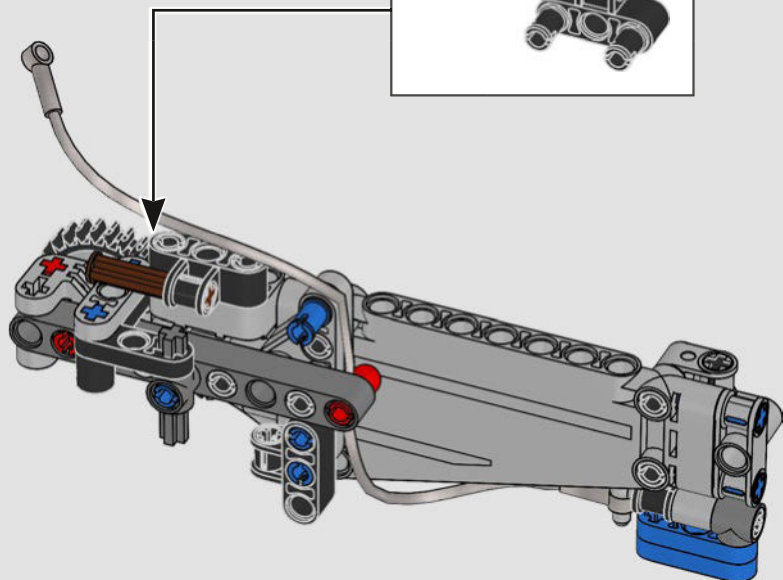
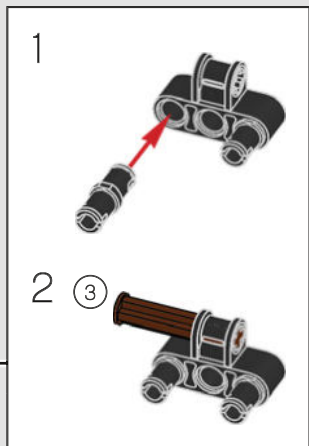

288

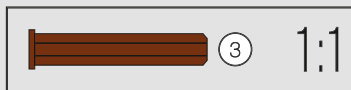
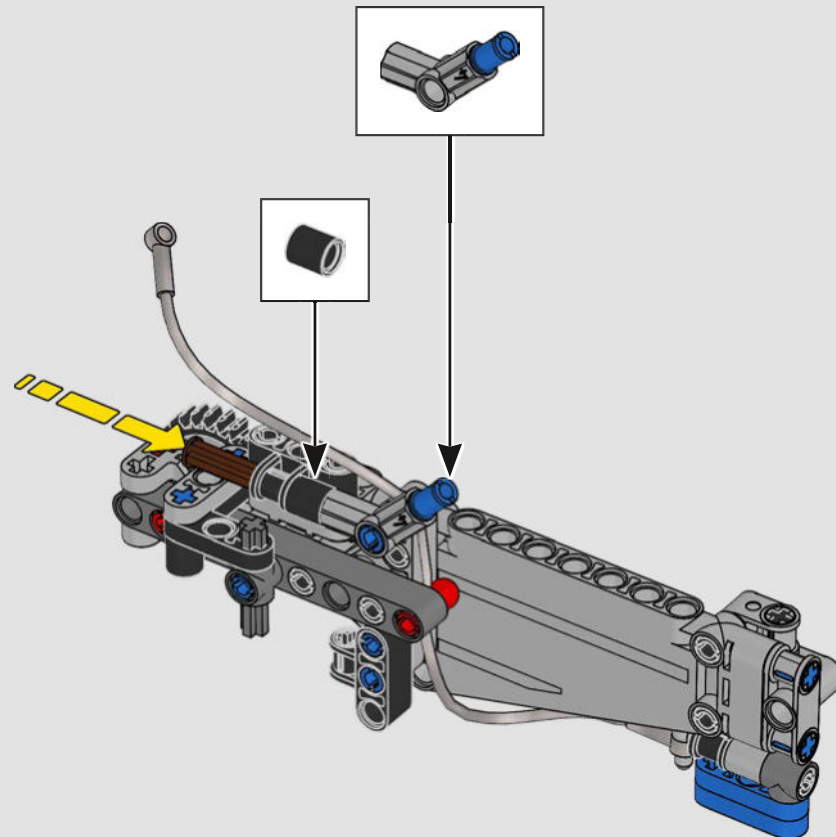

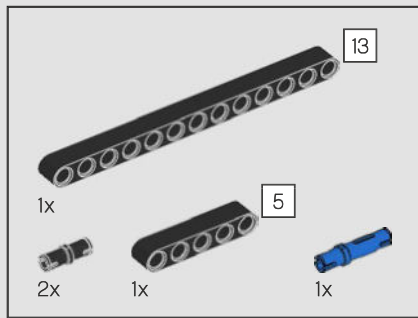

289

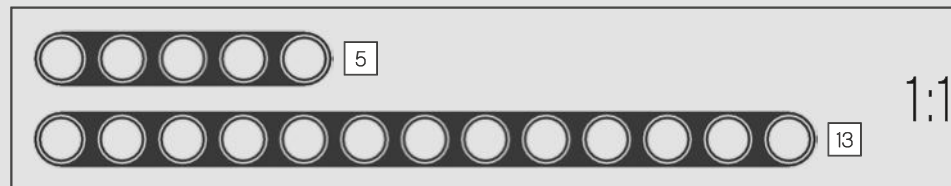
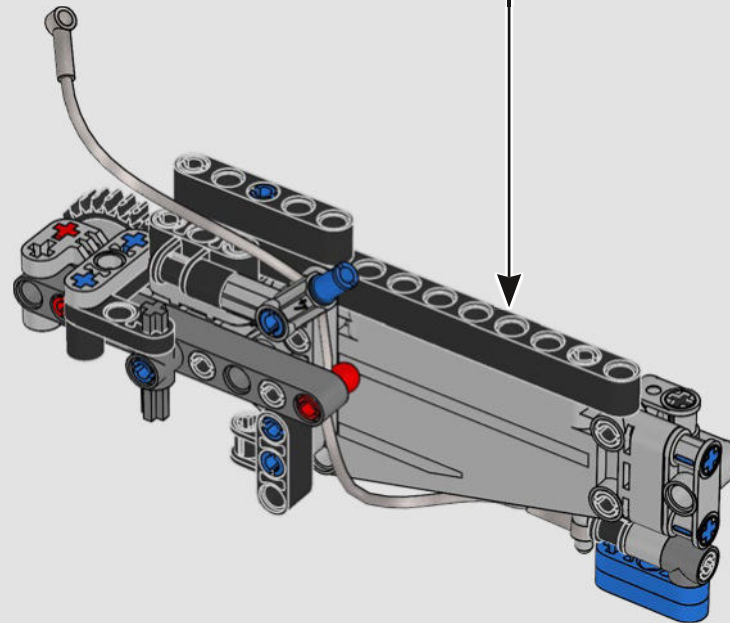
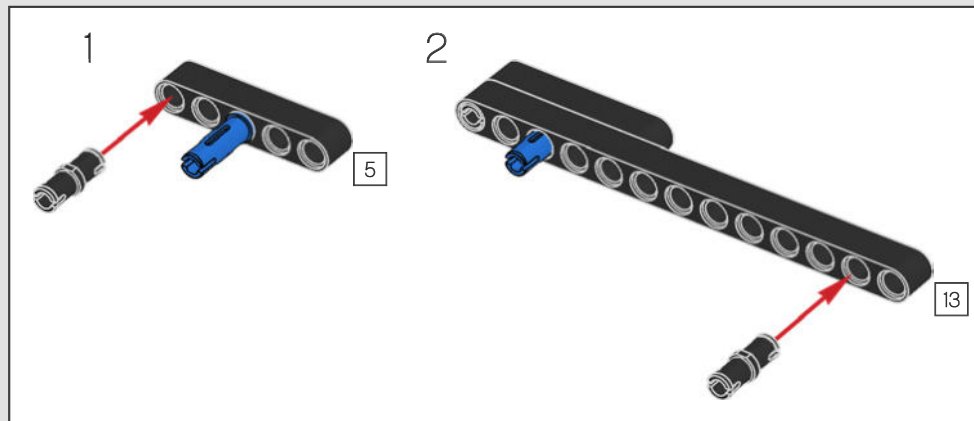

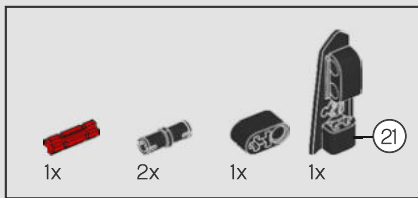

290

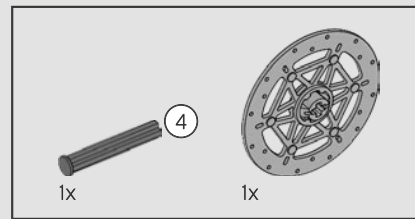
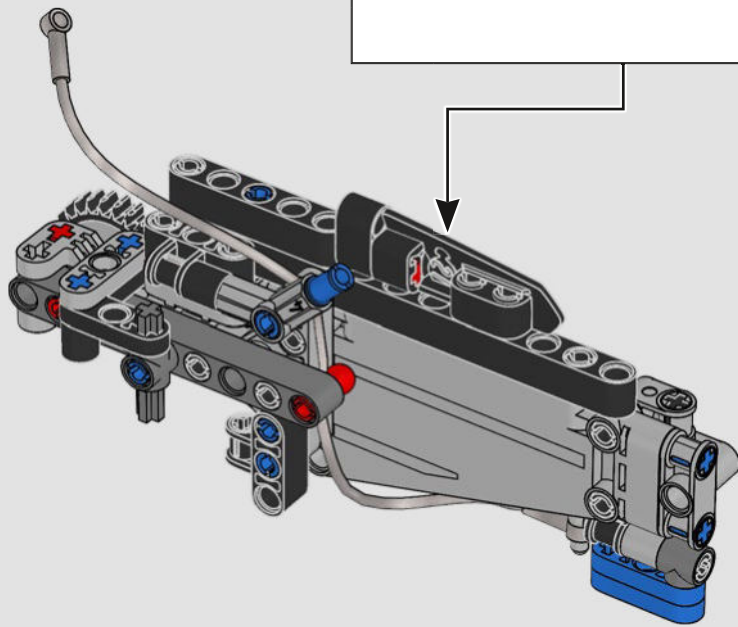
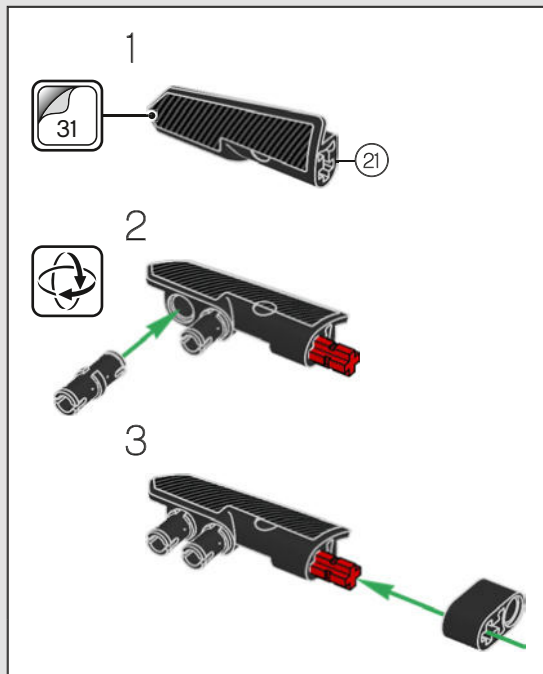

291

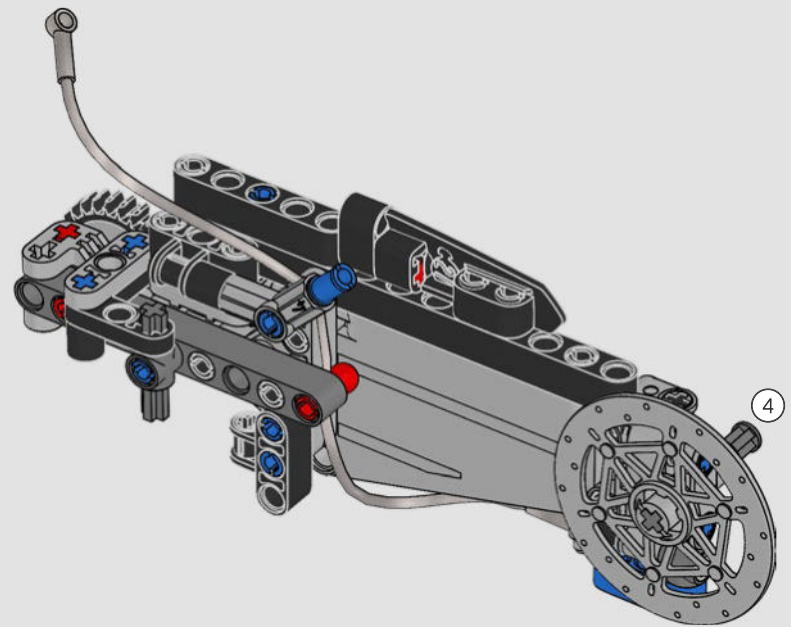
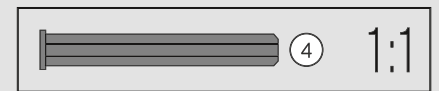



292

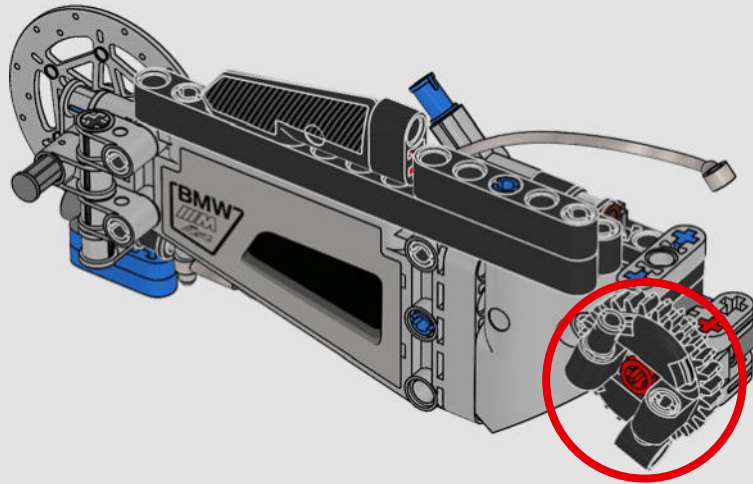

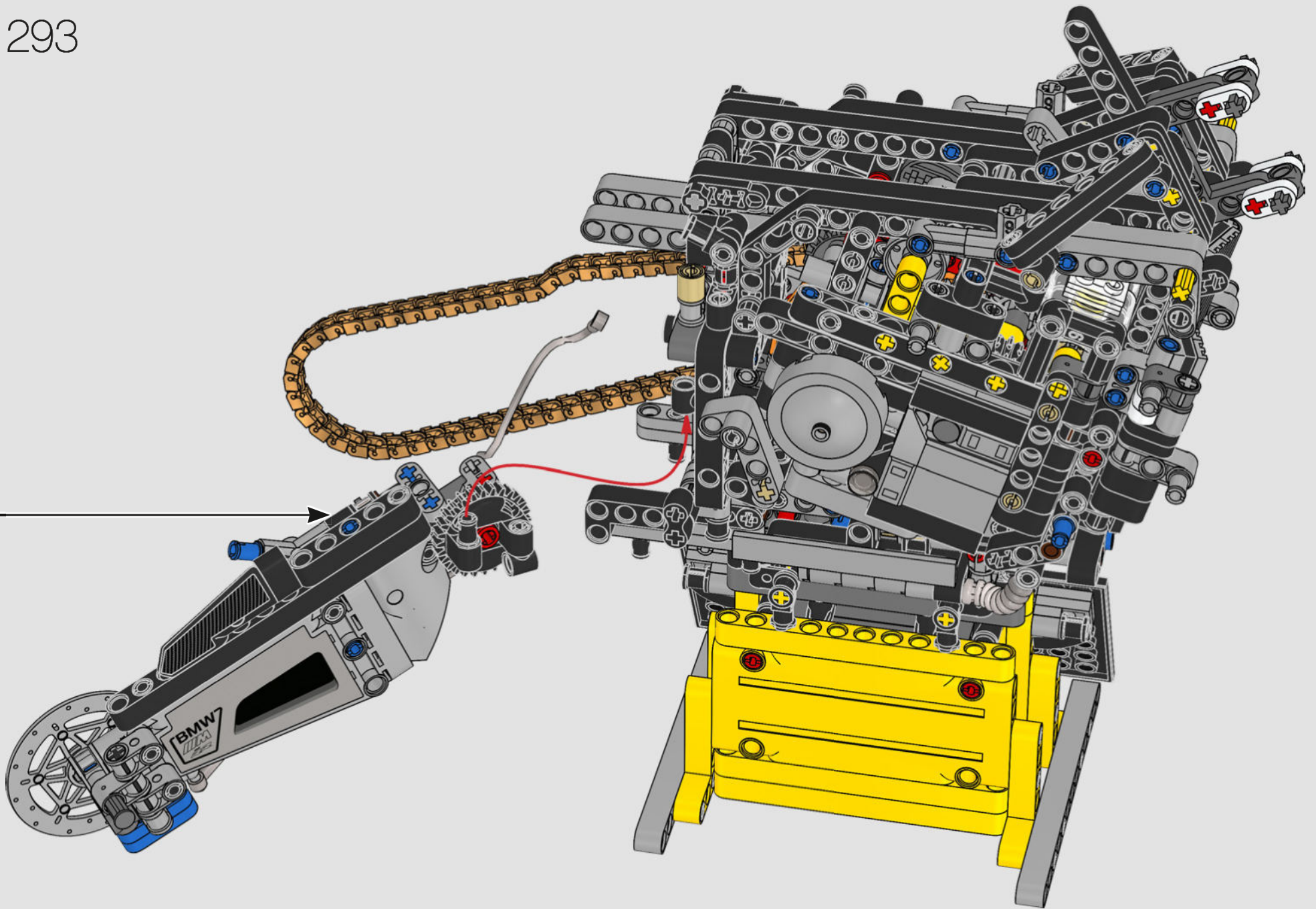

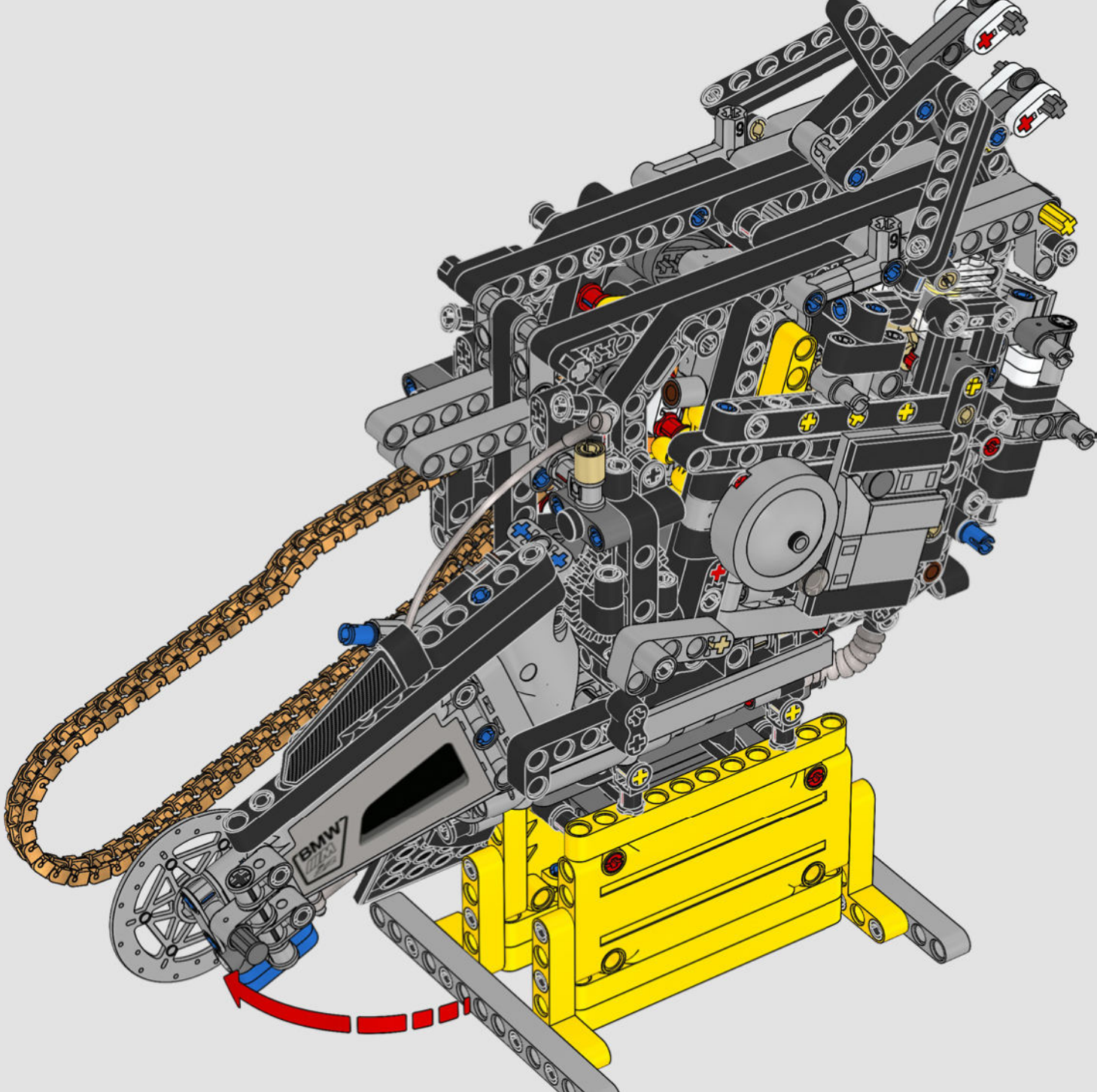

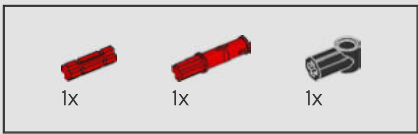

295

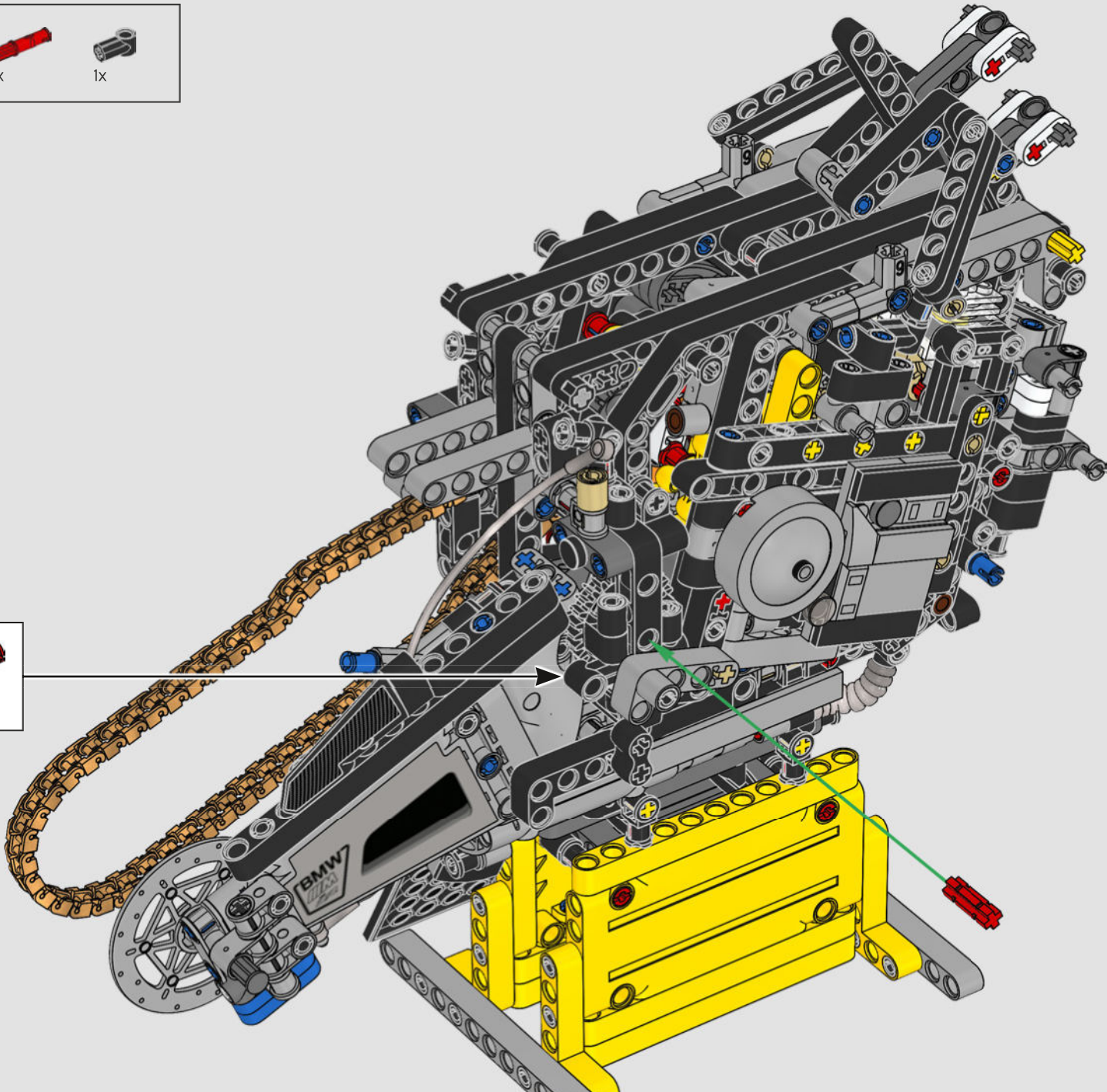
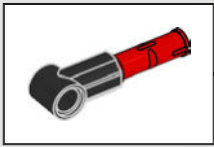

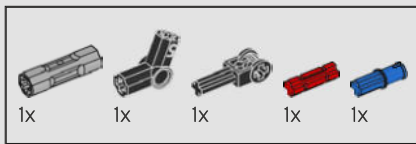

296

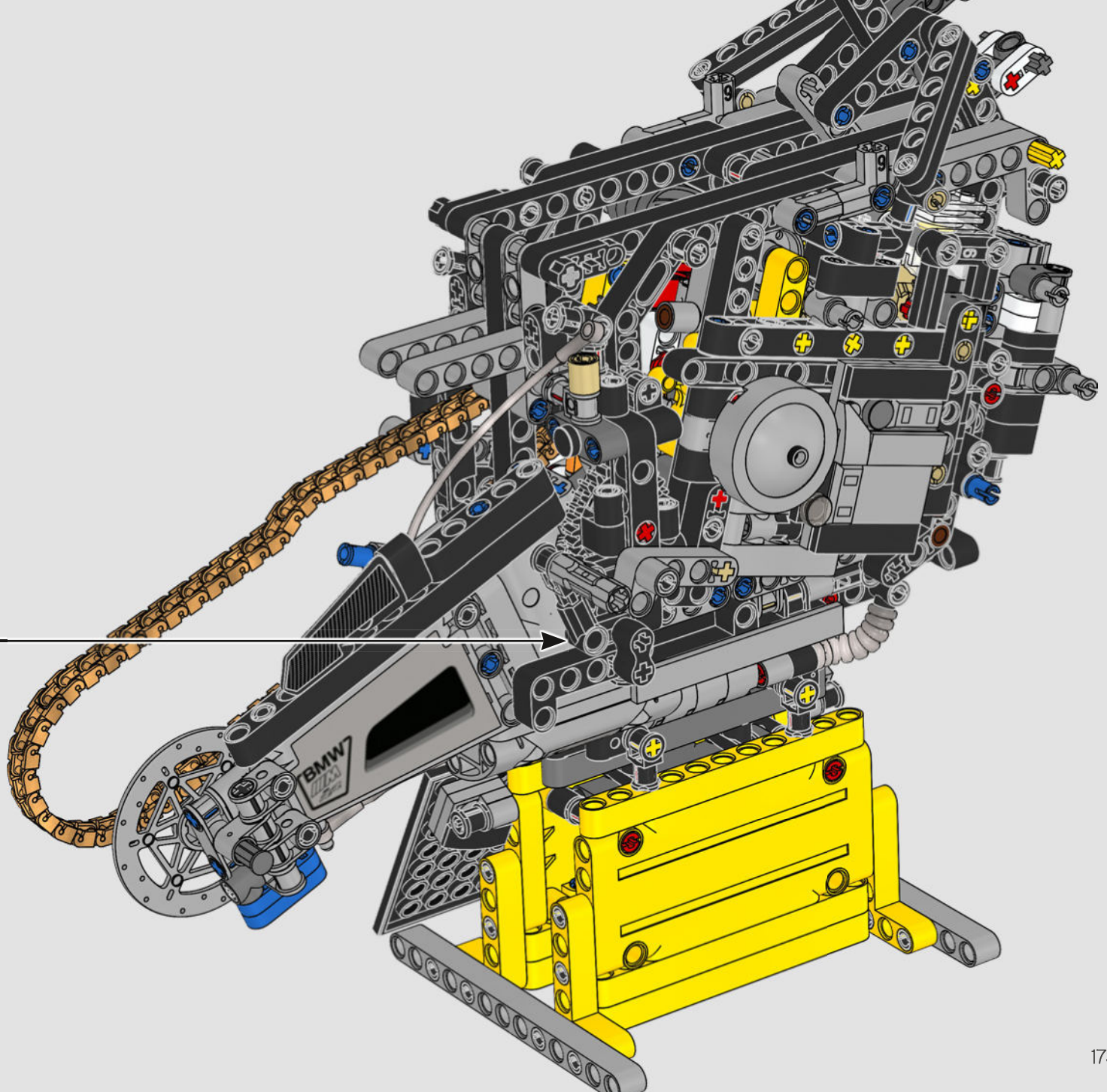
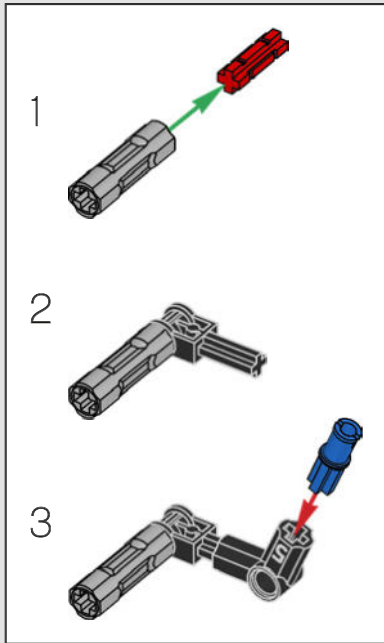

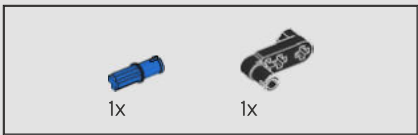

297

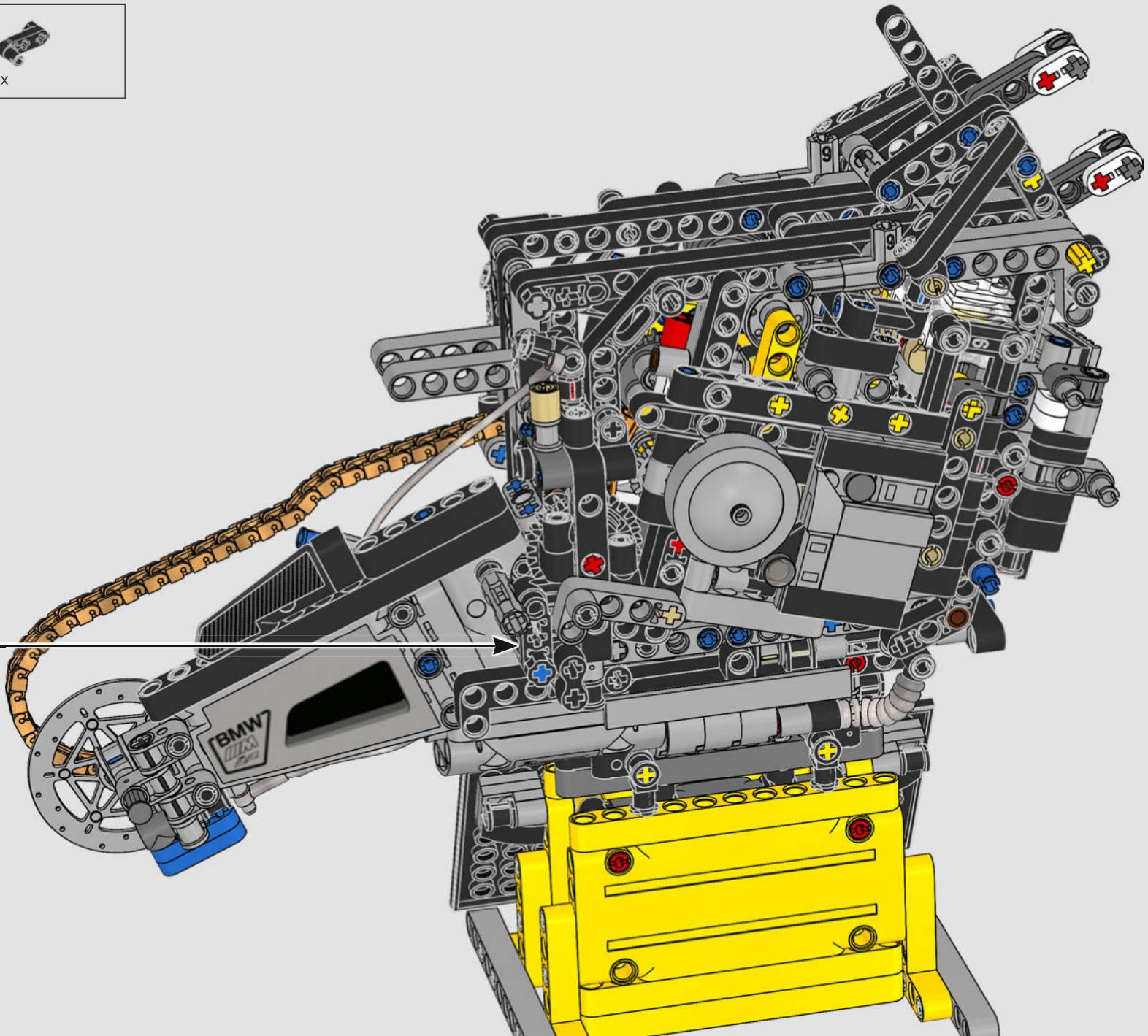
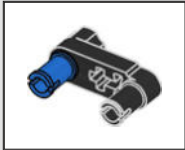

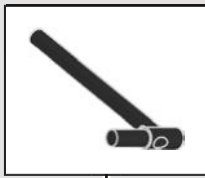
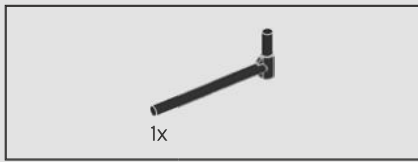

298

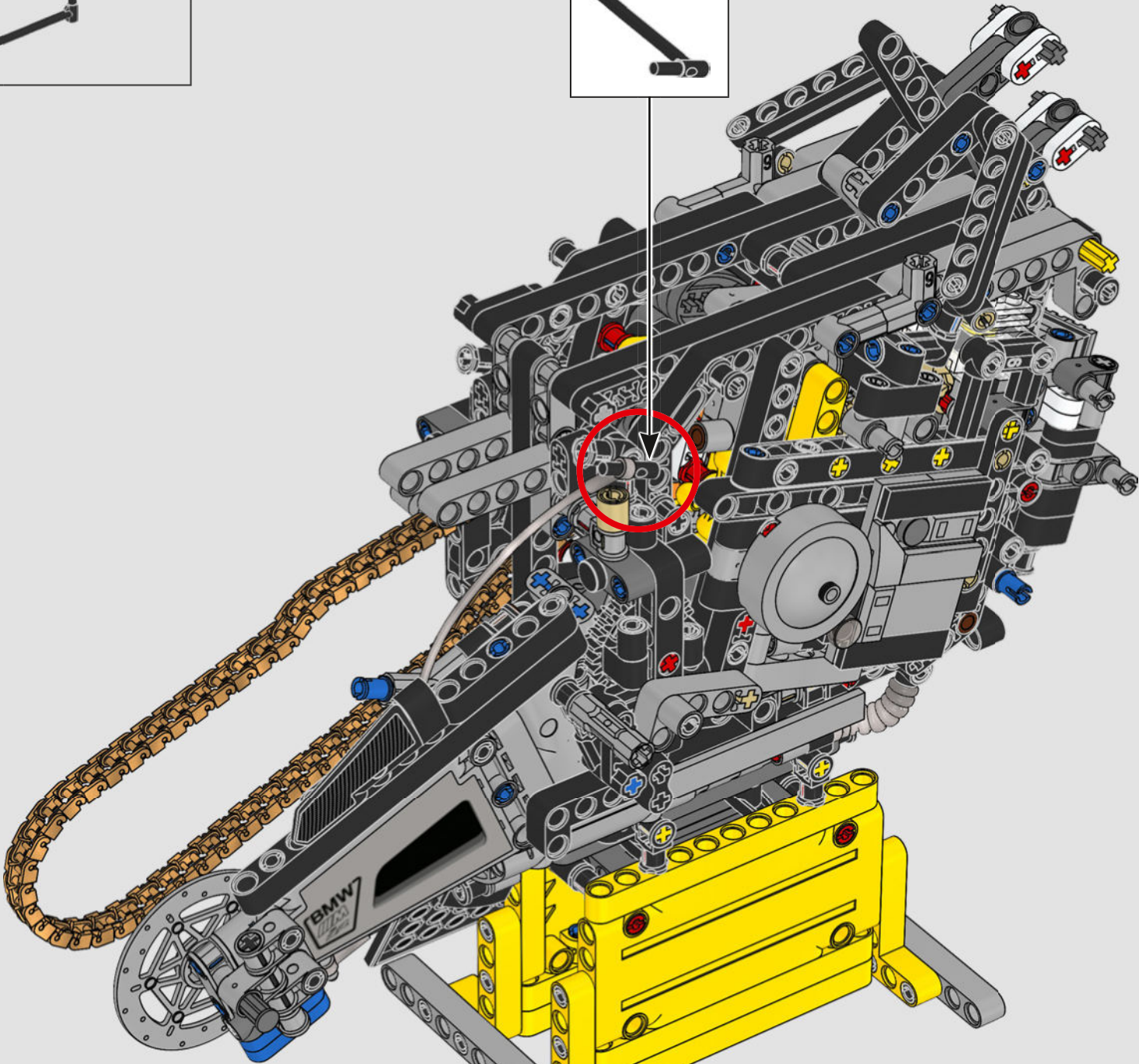

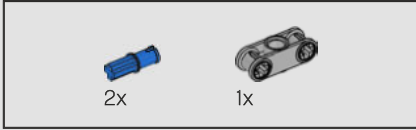
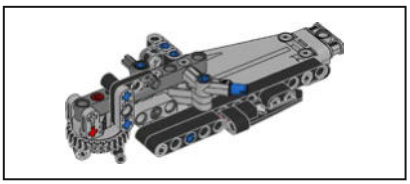

299

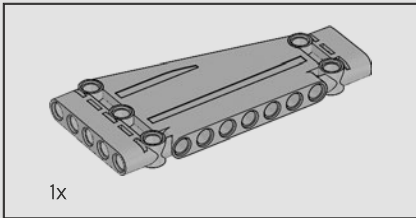
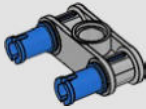

300

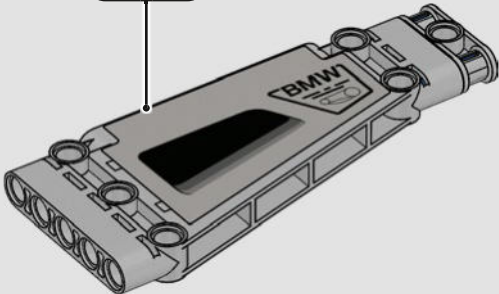

301

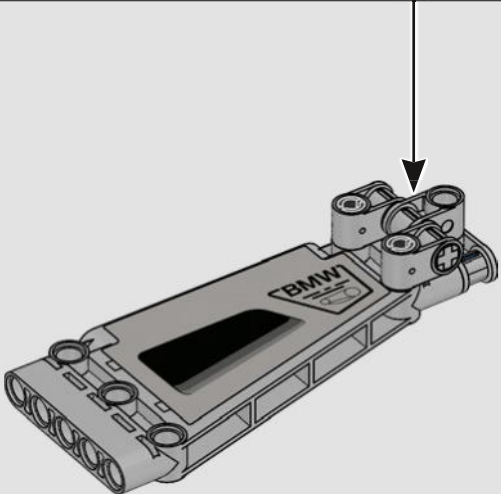
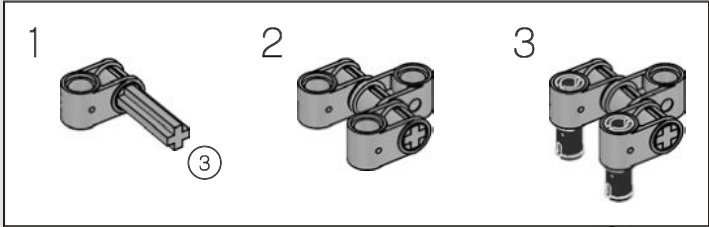

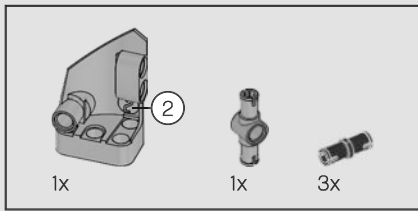

302

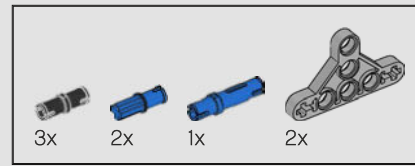
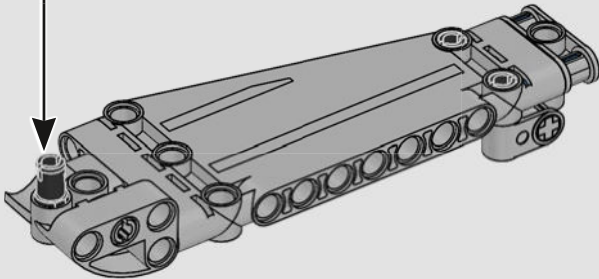
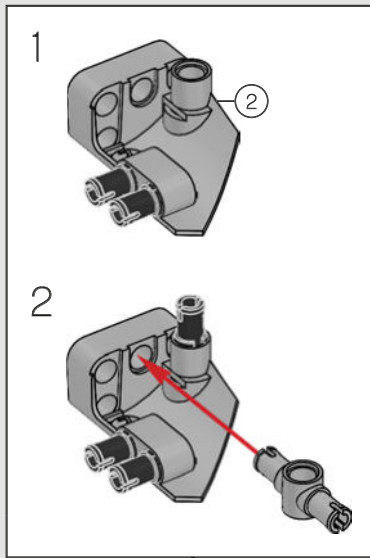

303

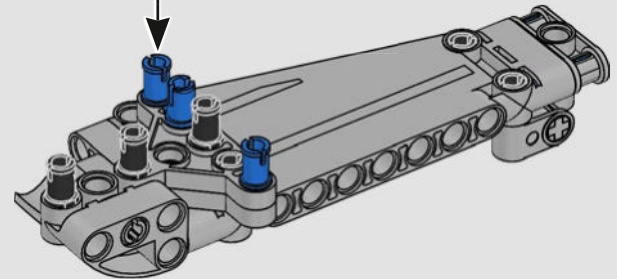
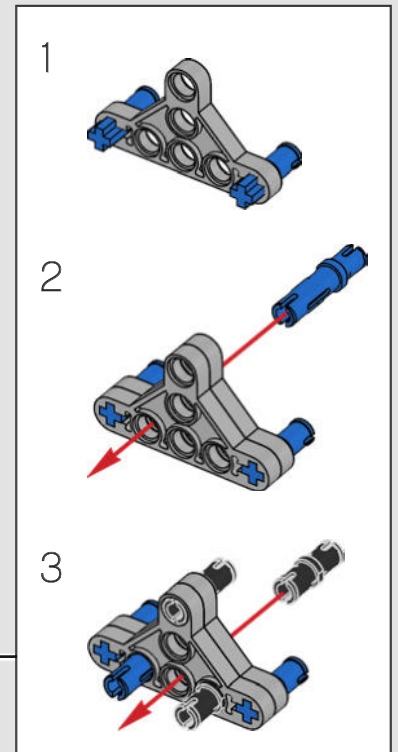

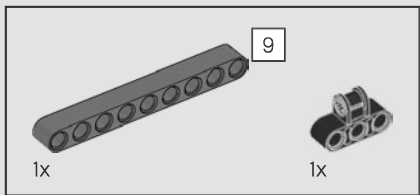

304

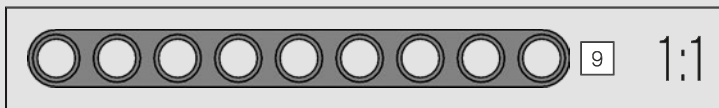
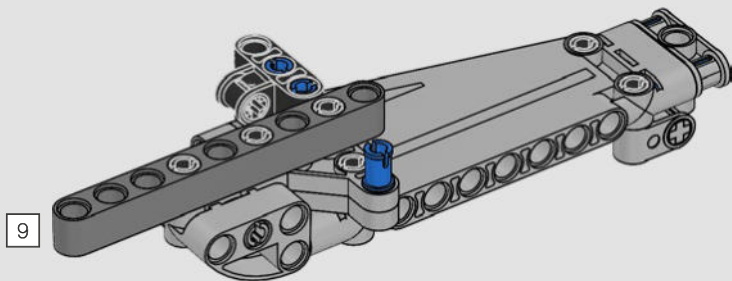

305

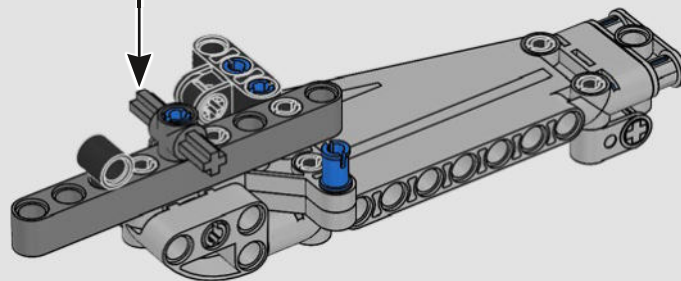

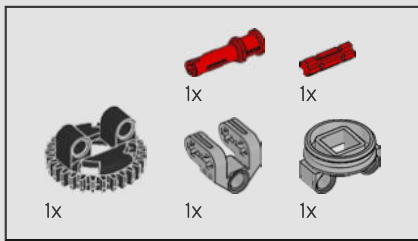

306

1

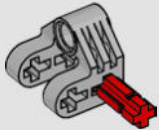

2

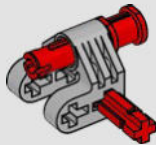

3

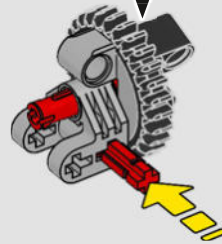

4



307

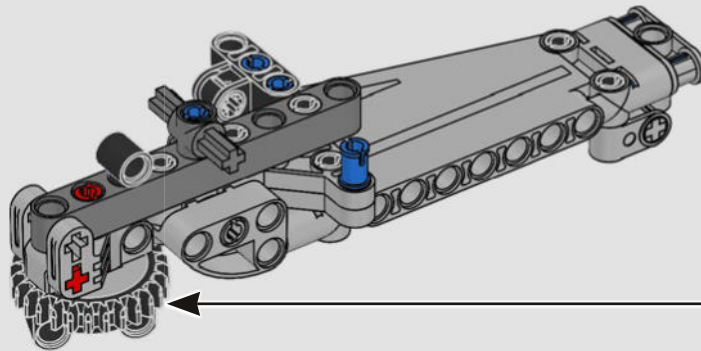

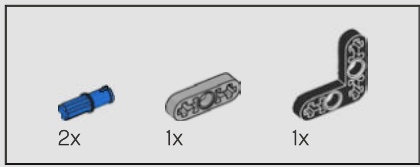

308

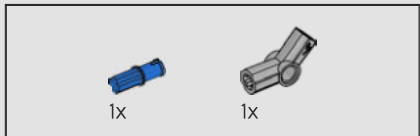
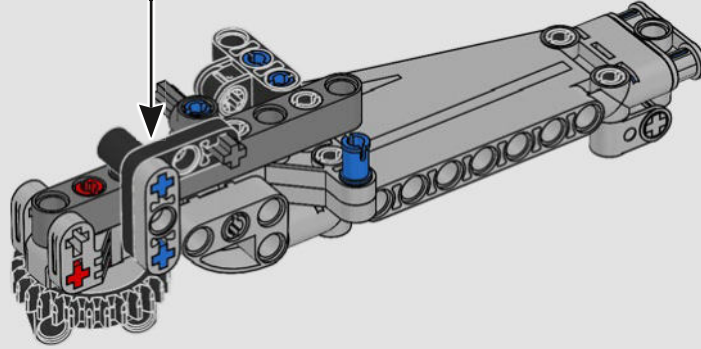
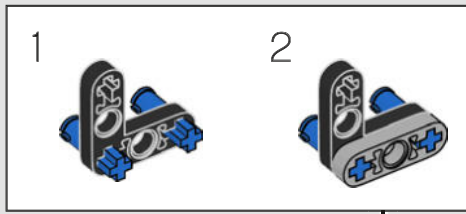

309

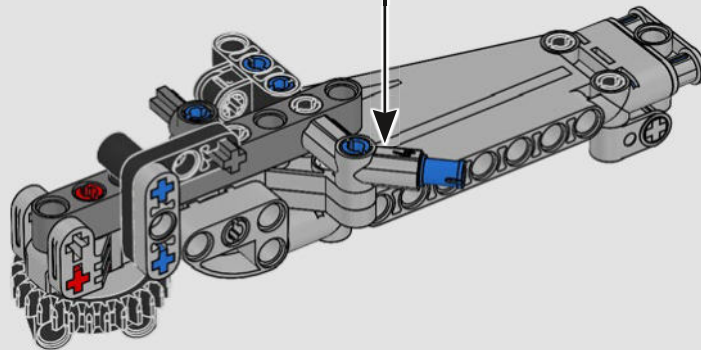
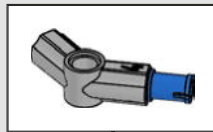

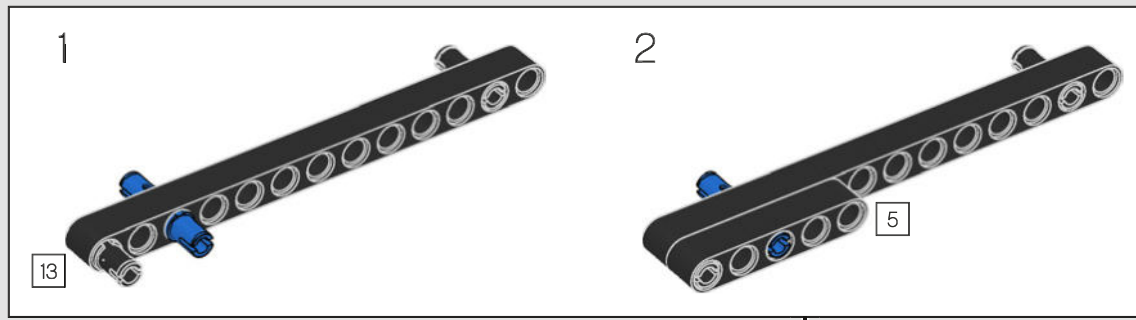
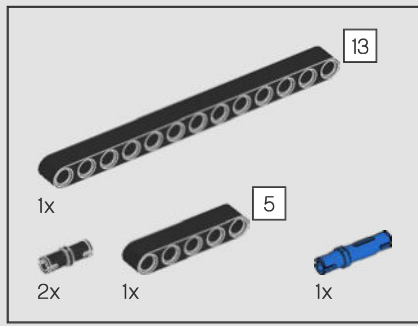

310

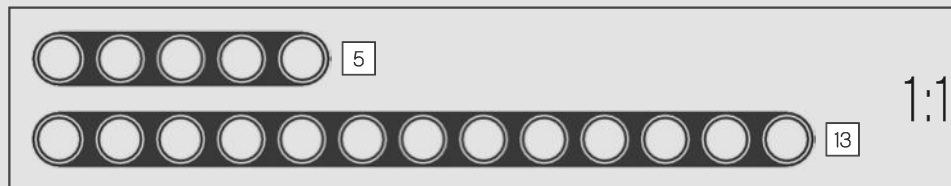
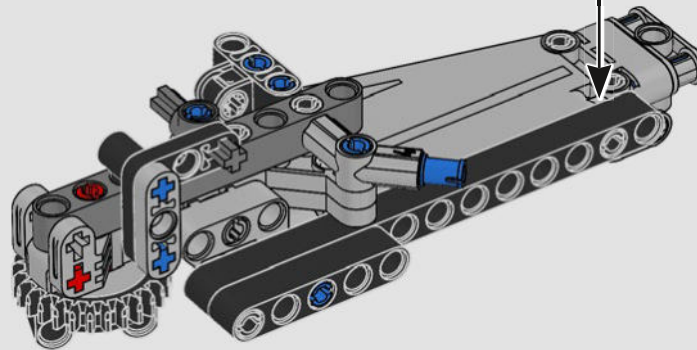

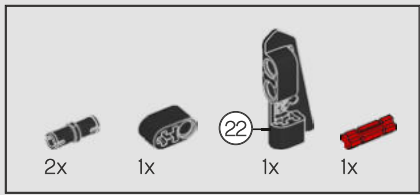

311

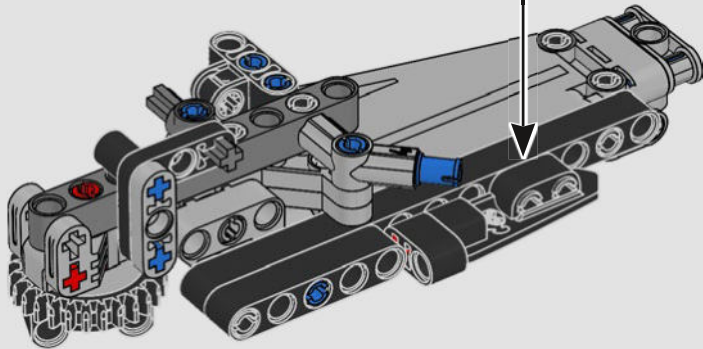
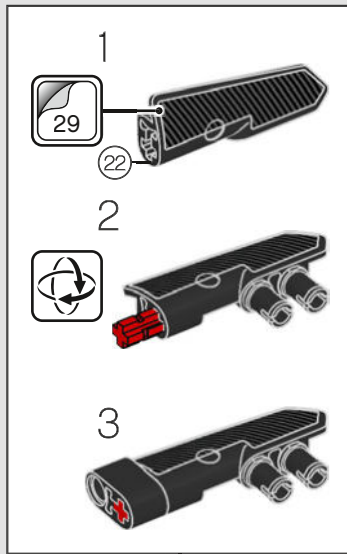

312

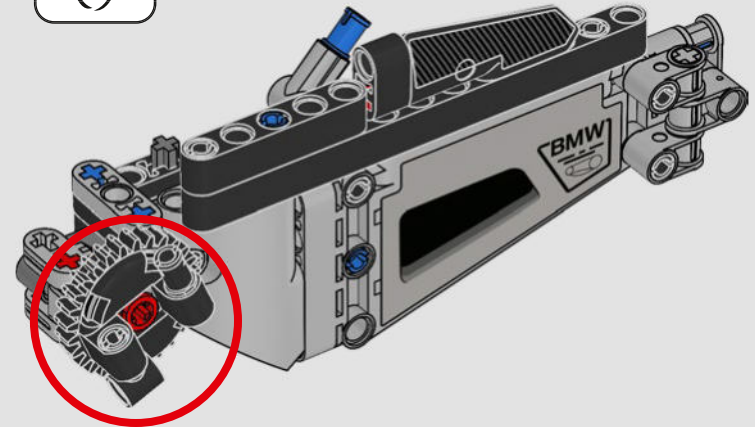
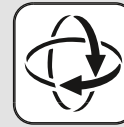

313

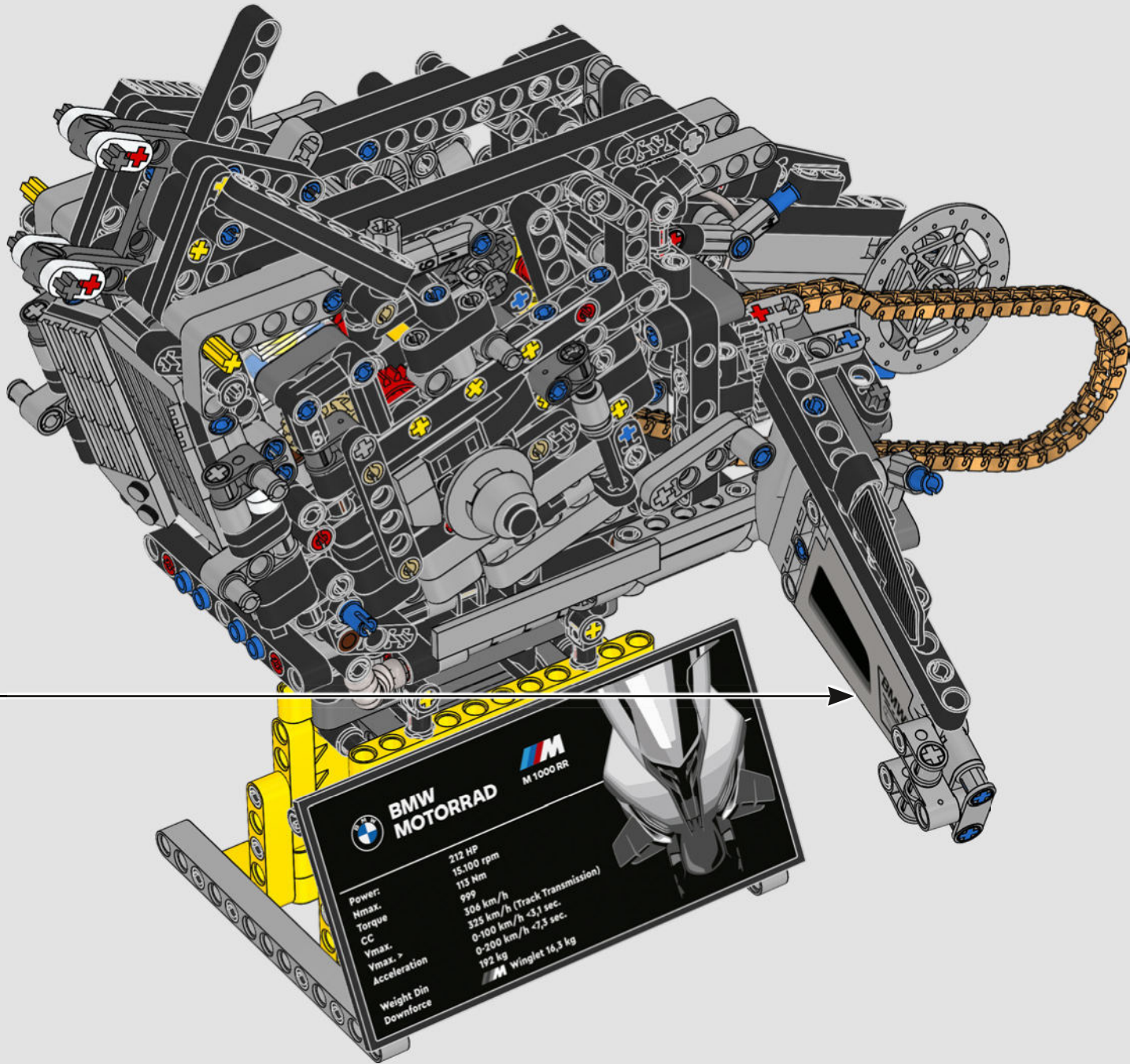

BMW MOTORRAD M 1000 RR

Power:	212 HP
Nmax.	15,100 rpm
Torque	113 Nm
CC	999
Vmax.	306 km/h (Track Transmission)
Acceleration	0-100 km/h 4.1 sec.
Weight Din	0-200 km/h 7.3 sec.
Downforce	192 kg Winglet 16,3 kg

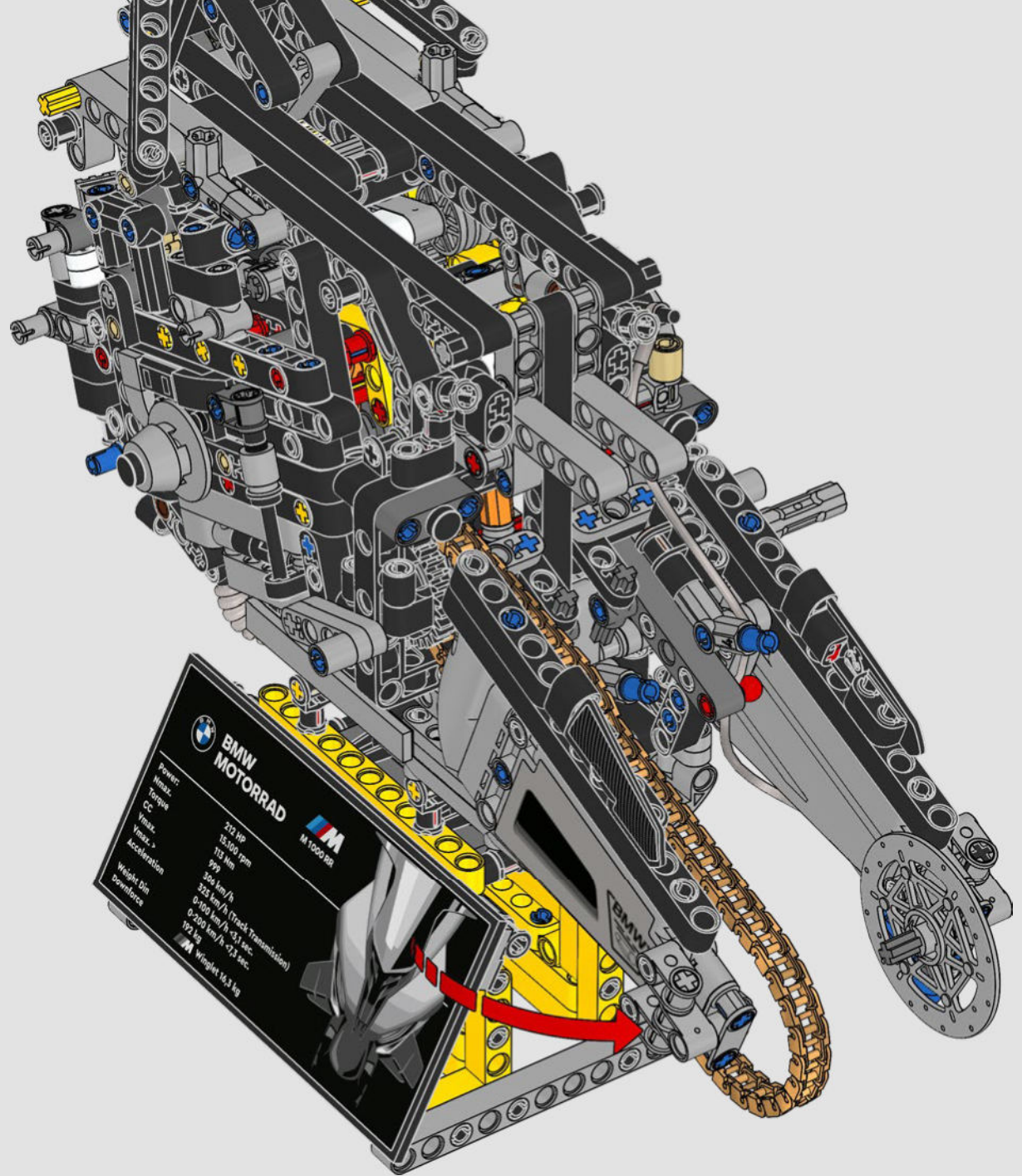
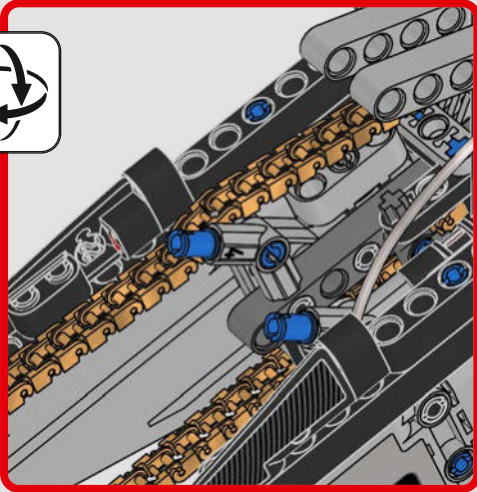

BMW MOTORRAD		M 1000 RR
Power	212 HP	
Max. Torque	15.100 rpm	
CC	113 Nm	
Max. Vmax.	999	
Max. Acceleration	306 km/h	
Weight-Dry	373 km/h (Track Transmission)	
Downforce	0-100 km/h < 3,1 sec.	
	0-200 km/h < 7,1 sec.	
	192 kg	
	Winglet 16,3 kg	

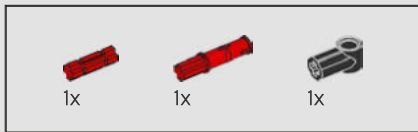

315

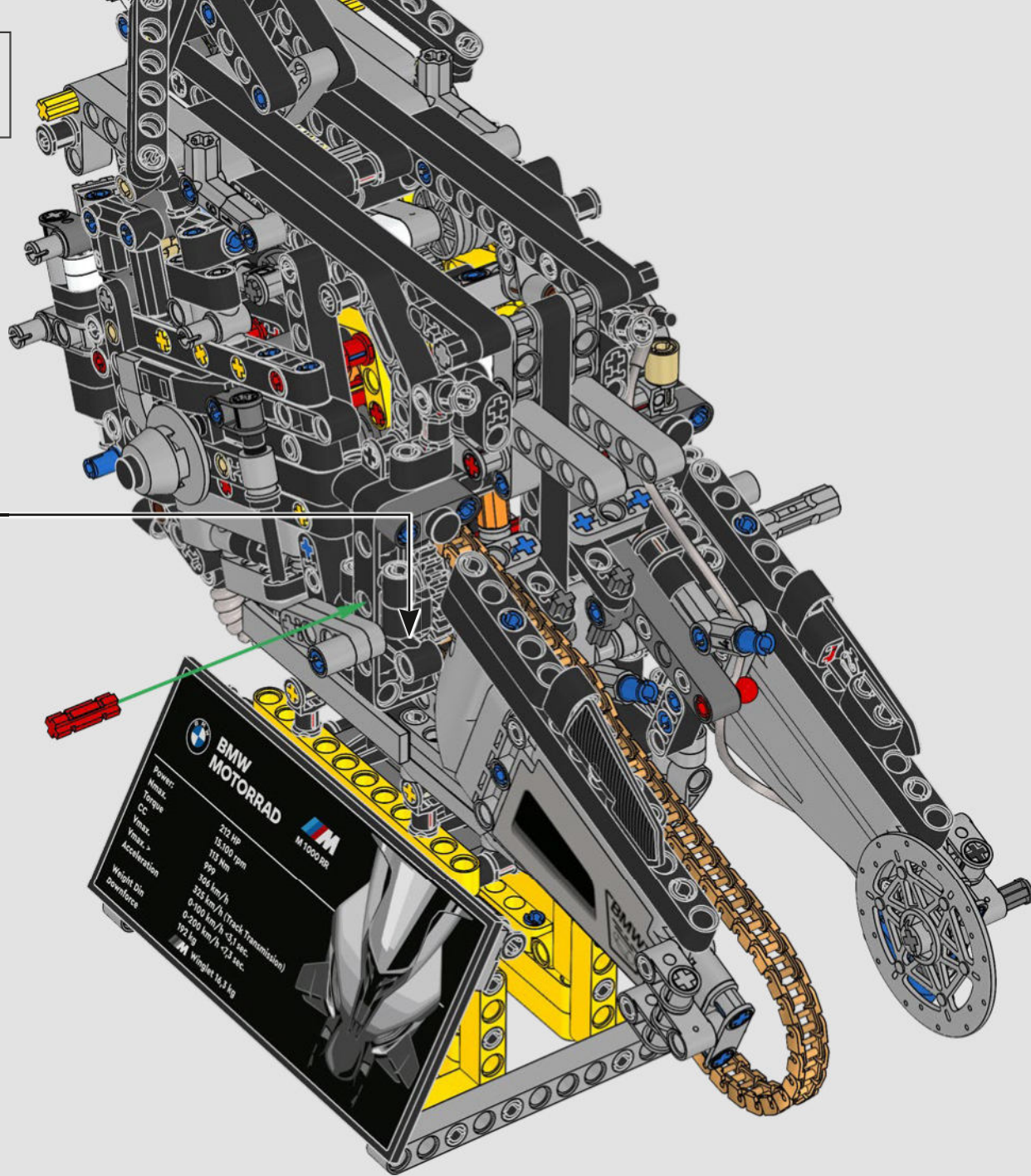
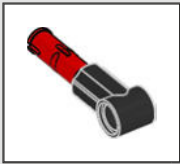

BMW MOTORRAD  **M 1000 RR**

Power: 212 hp
 Max. Torque: 15.100 rpm
 CC: 1173 cm³
 Vmax: 309 km/h
 Vmax + Acceleration: 0-200 km/h $\lt; 2.3 \text{ sec.}$
 Weight (Dry): 192 kg
 (with fuel 18,3 kg)

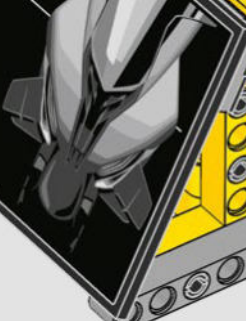

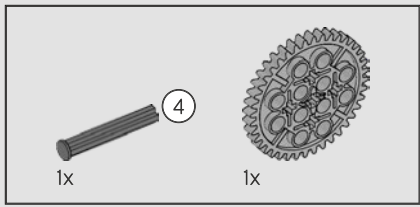

316

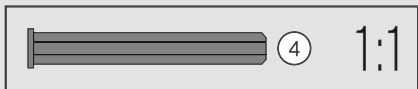
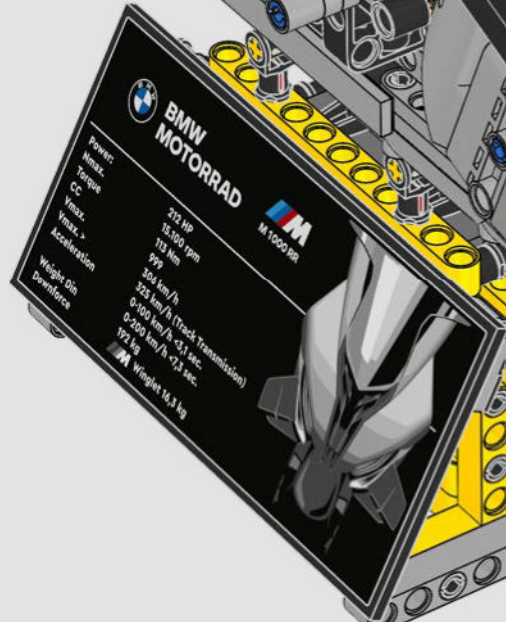
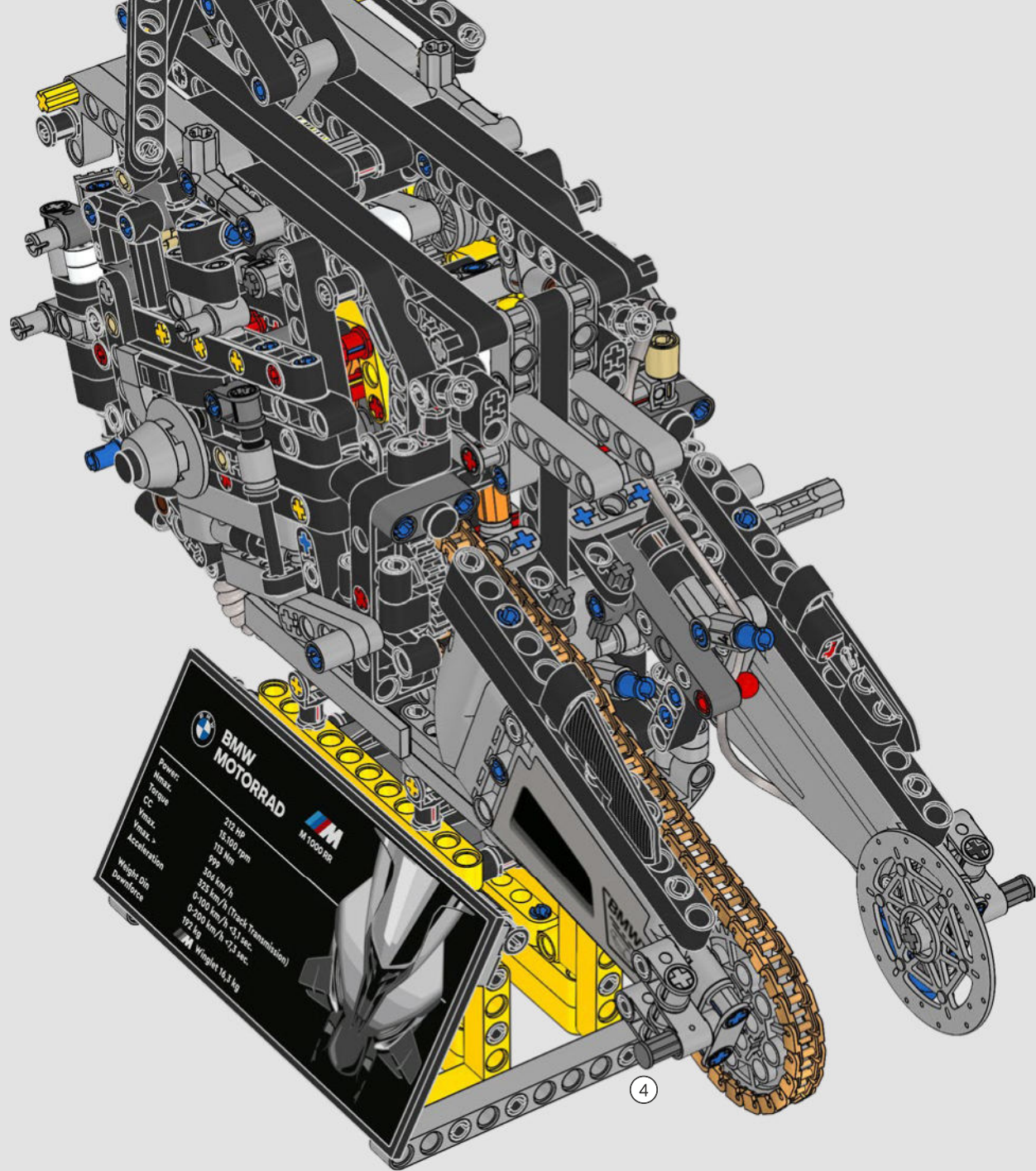

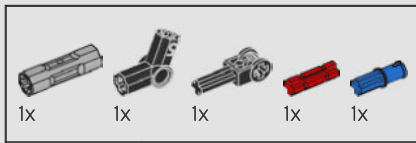

317

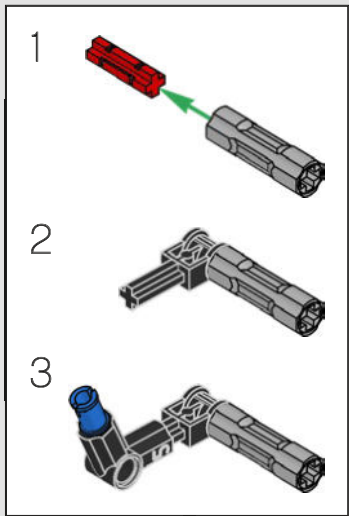
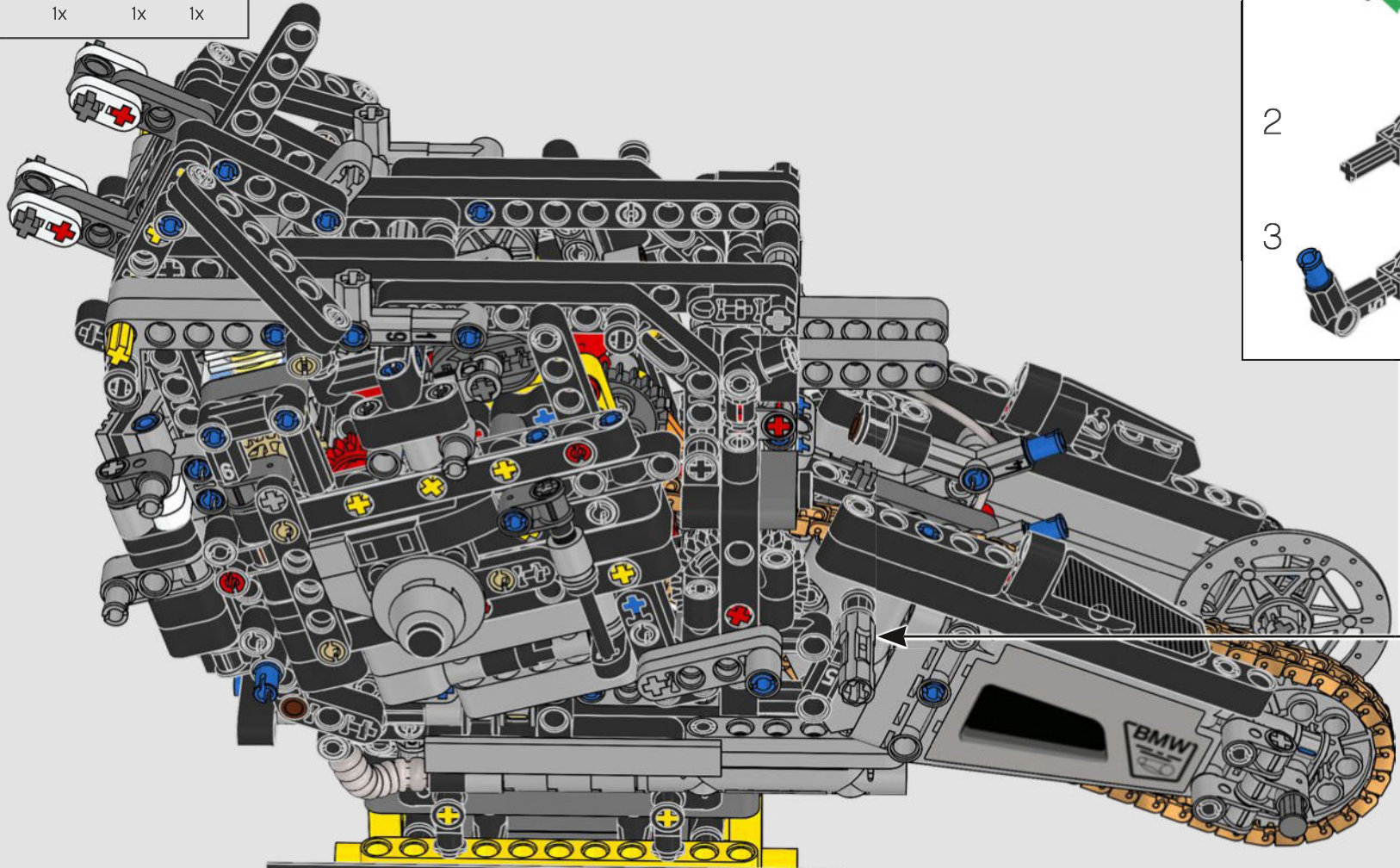

	BMW	
	MOTORRAD	M 1000 RR
Power:	212 HP	
Nmax.	15,100 rpm	
Torque	113 Nm	
CC	999	
Vmax.	306 km/h	
Vmax. >	325 km/h (Track Transmission)	
Acceleration	0-100 km/h <3,1 sec.	
	0-200 km/h <7,3 sec.	
Weight Din	192 kg	
Downforce	Winglet 16,3 kg	

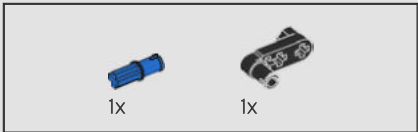

318

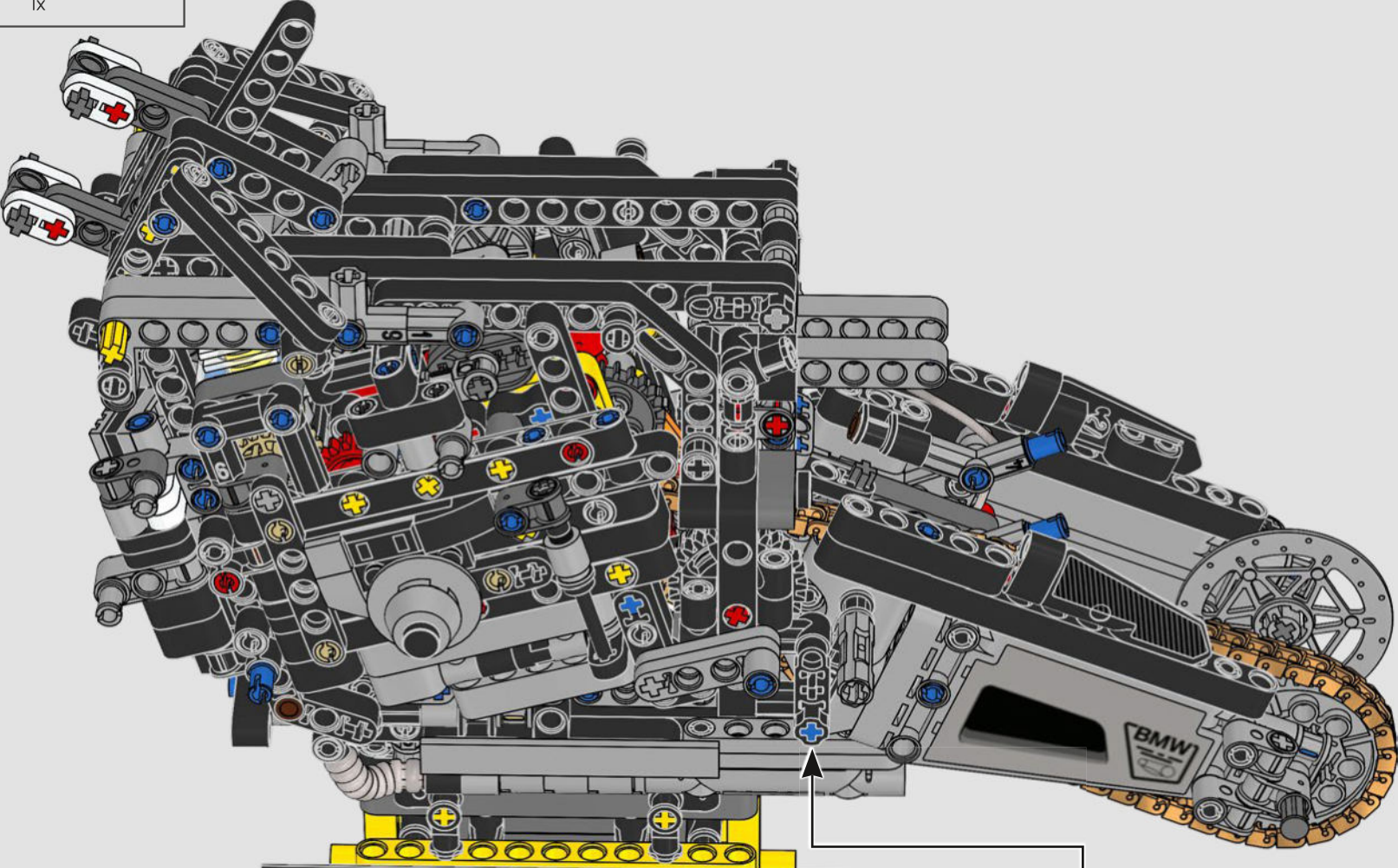



BMW
MOTORRAD



M
1000 RR

Power: 212 HP

Nmax: 15.100 rpm

Torque: 113 Nm

CC: 999

Vmax: 306 km/h

Vmax. > 325 km/h (Track Transmission)

Acceleration: 0-100 km/h <3,1 sec.
0-200 km/h <7,3 sec.

Weight Din: 192 kg

Downforce:  Winglet 16,3 kg

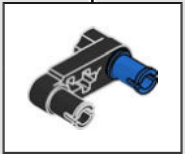

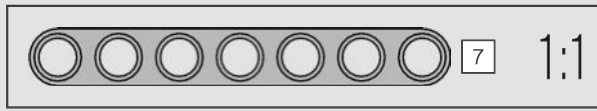
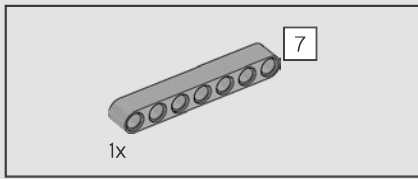
319



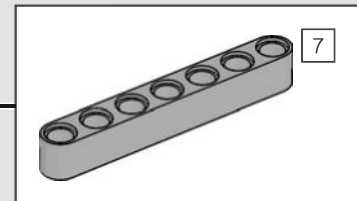
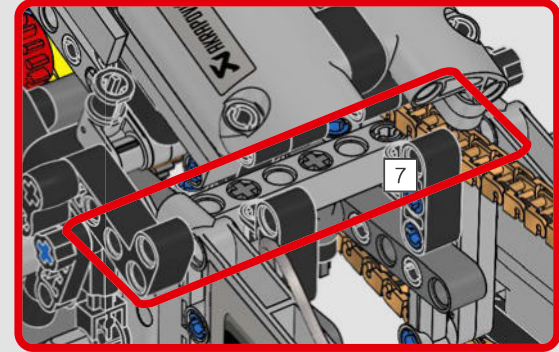
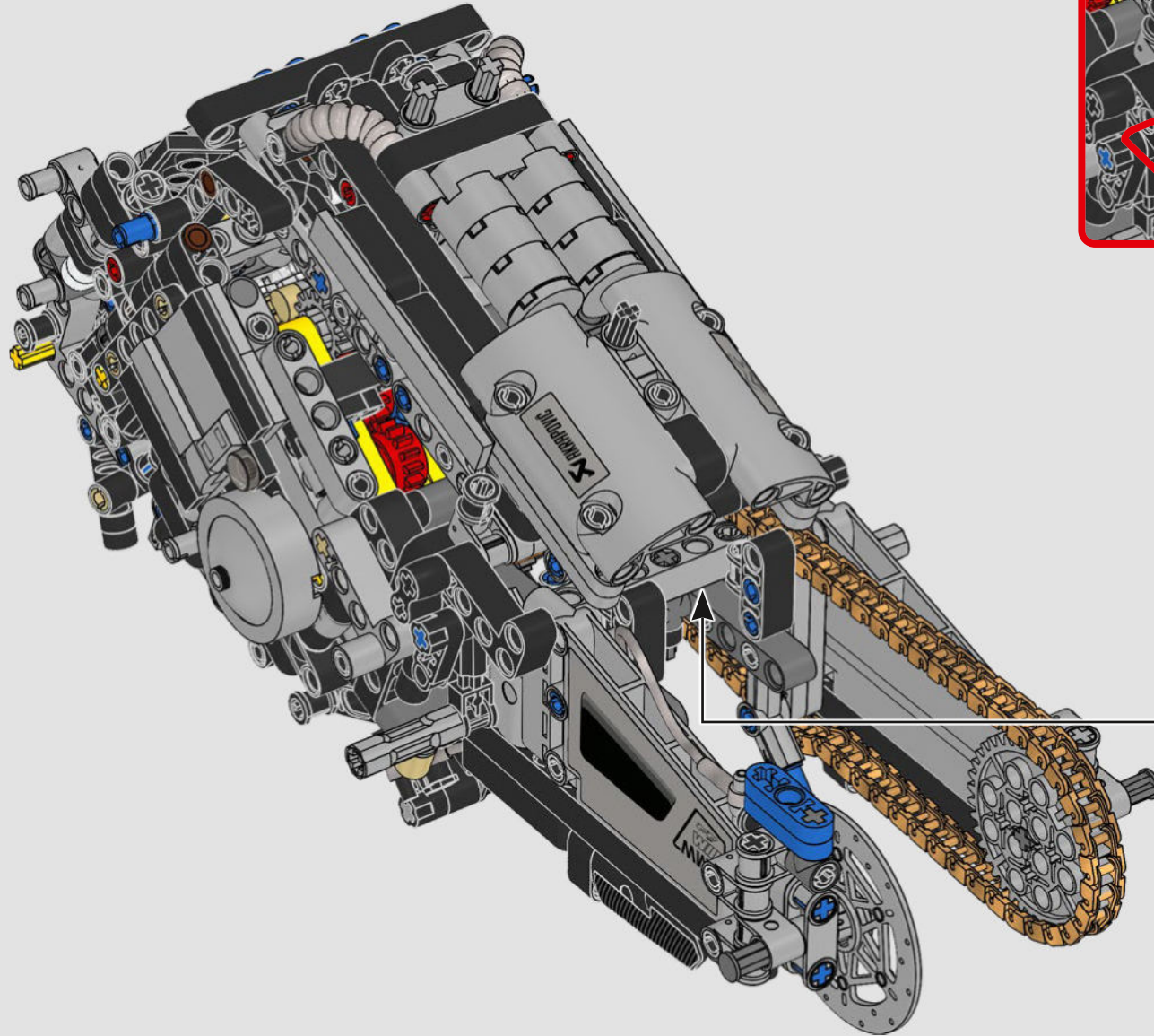

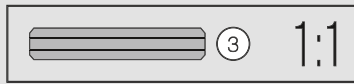
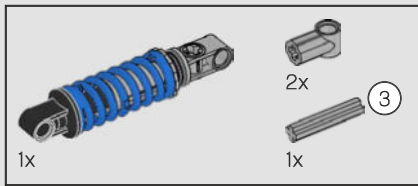
320

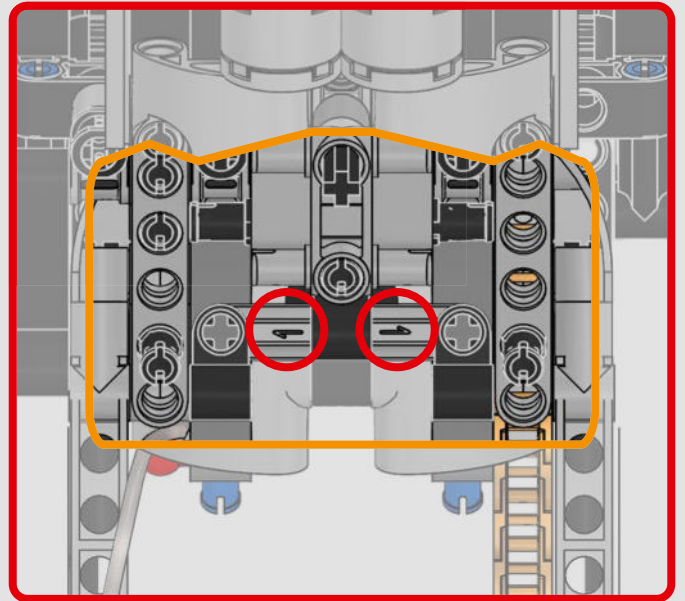
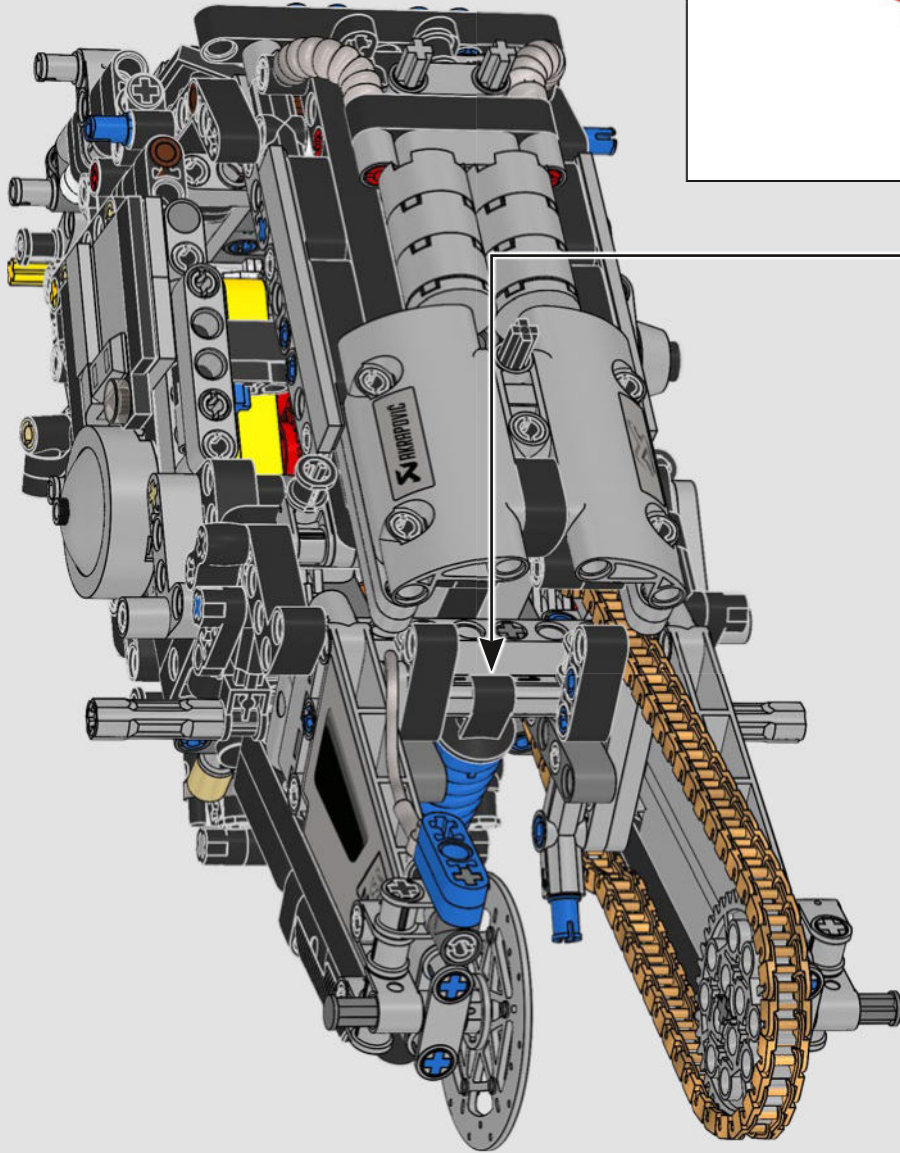
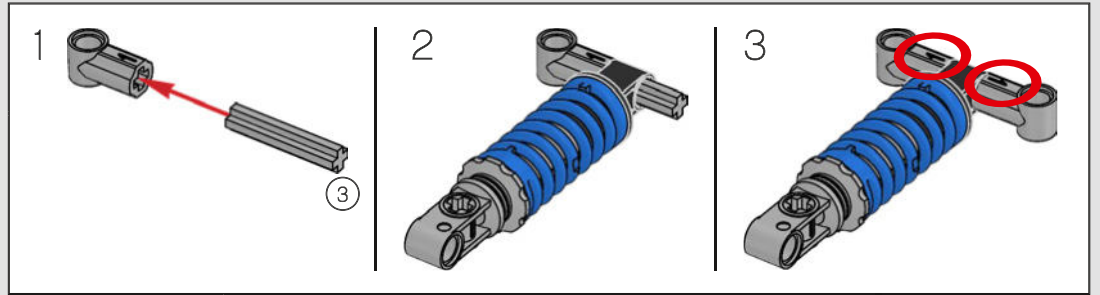

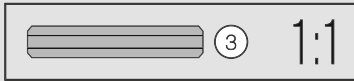
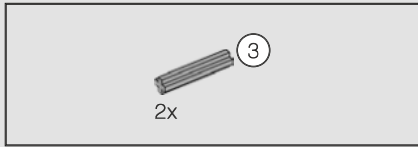

321

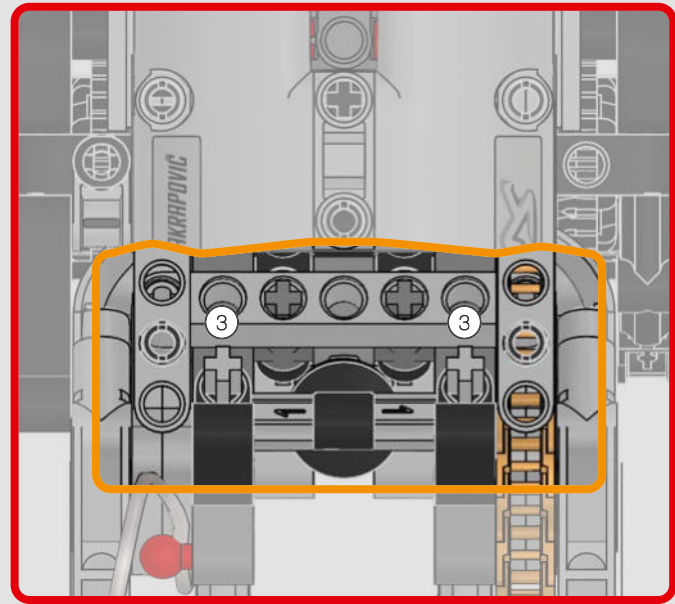
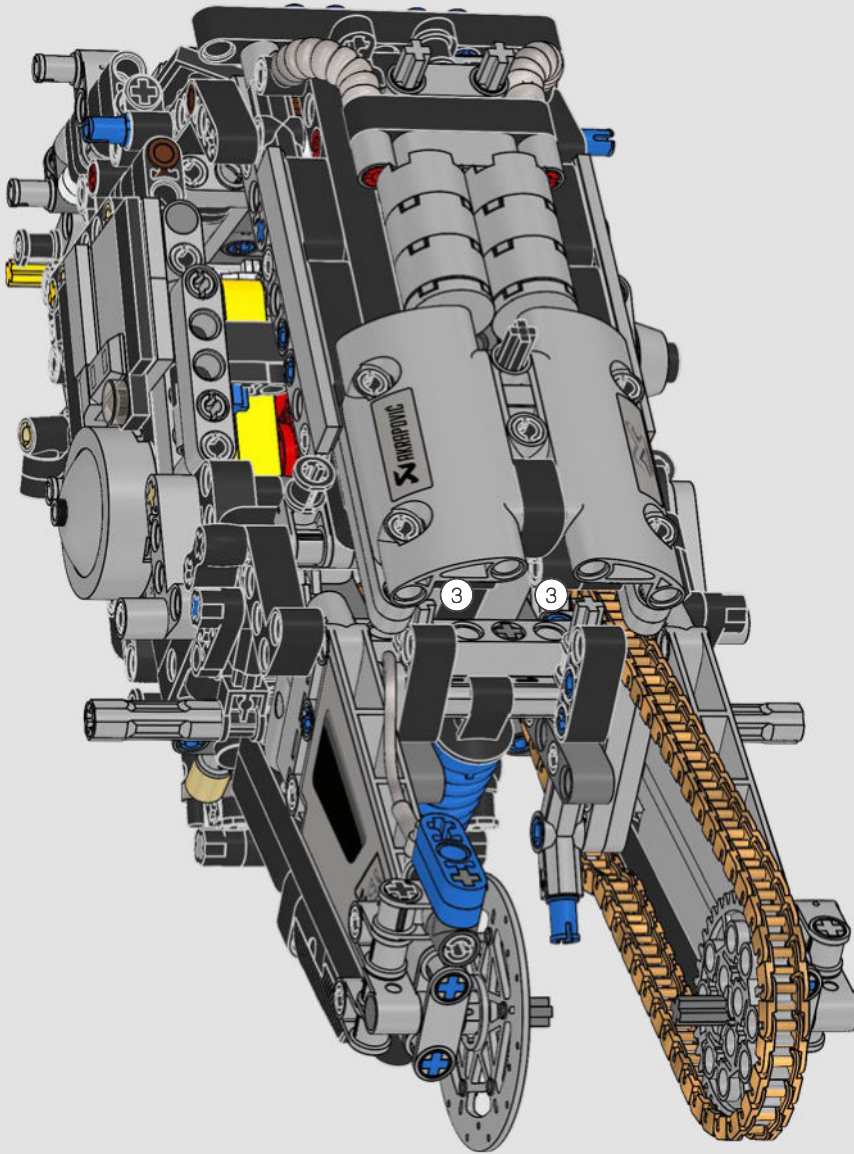

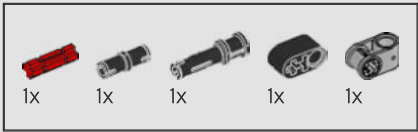

322

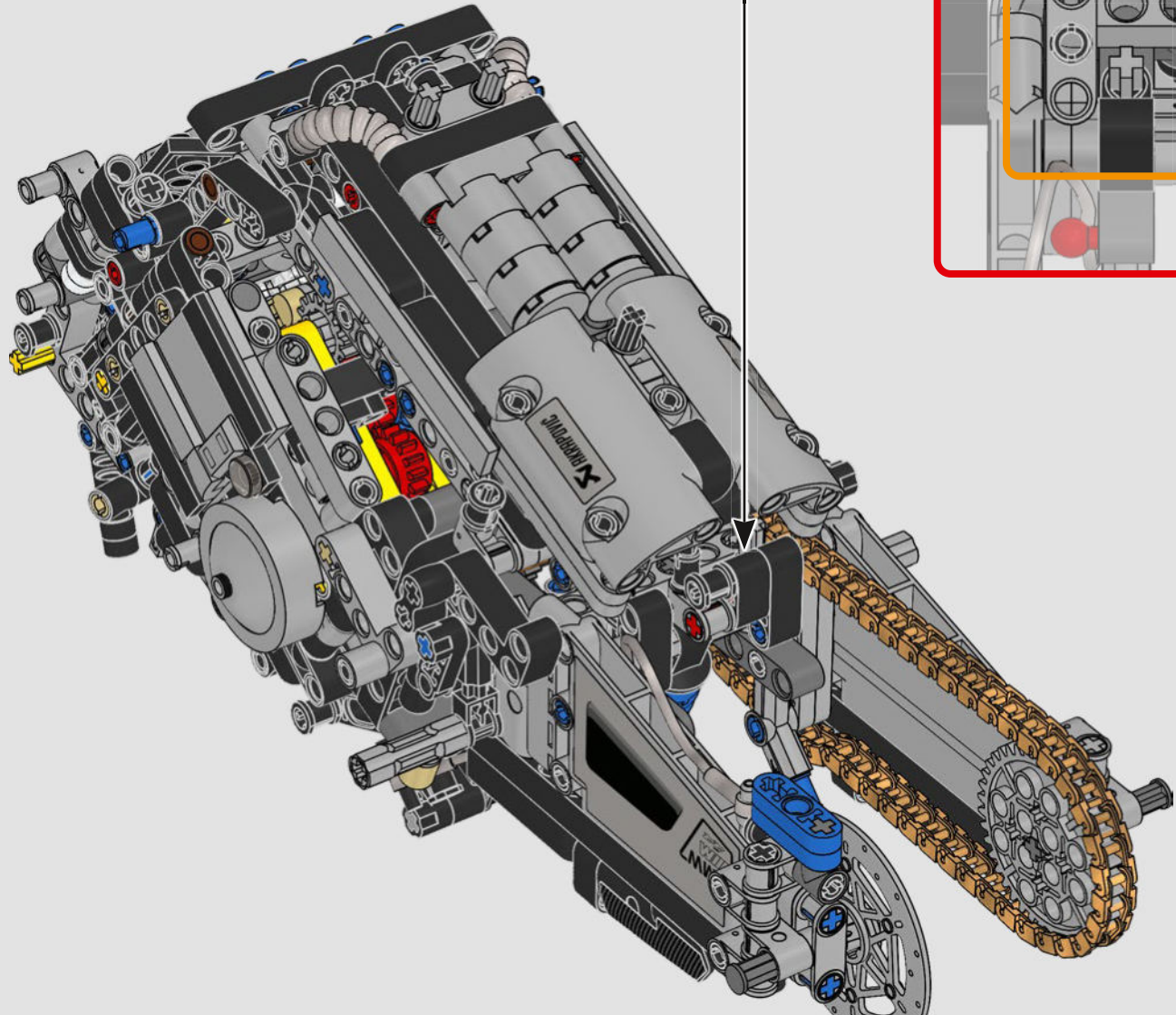
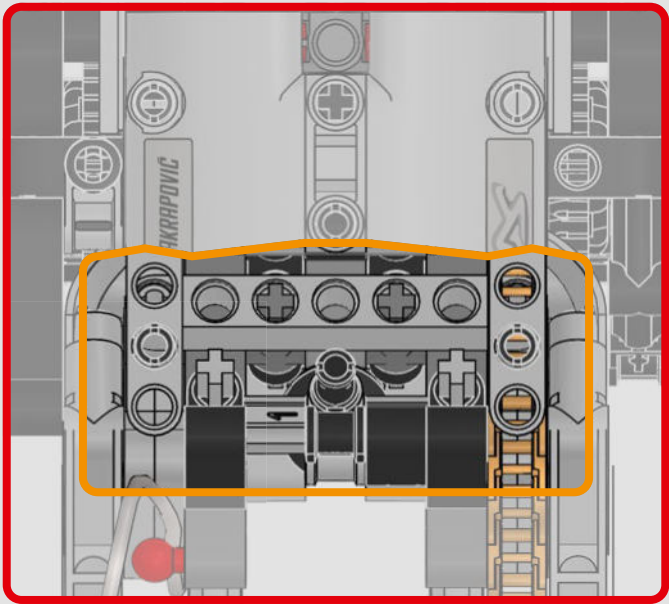
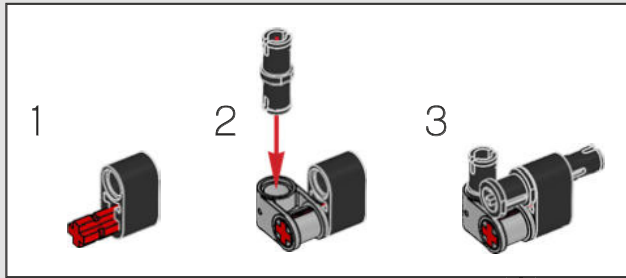

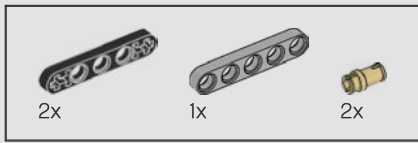

323

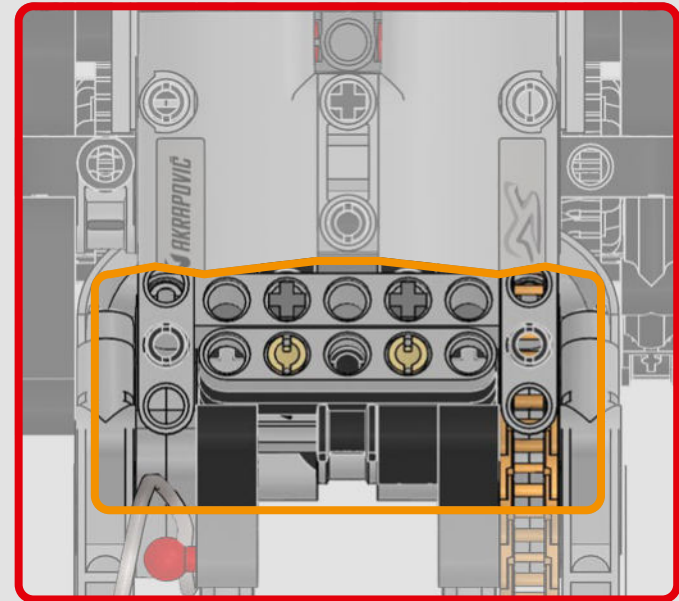
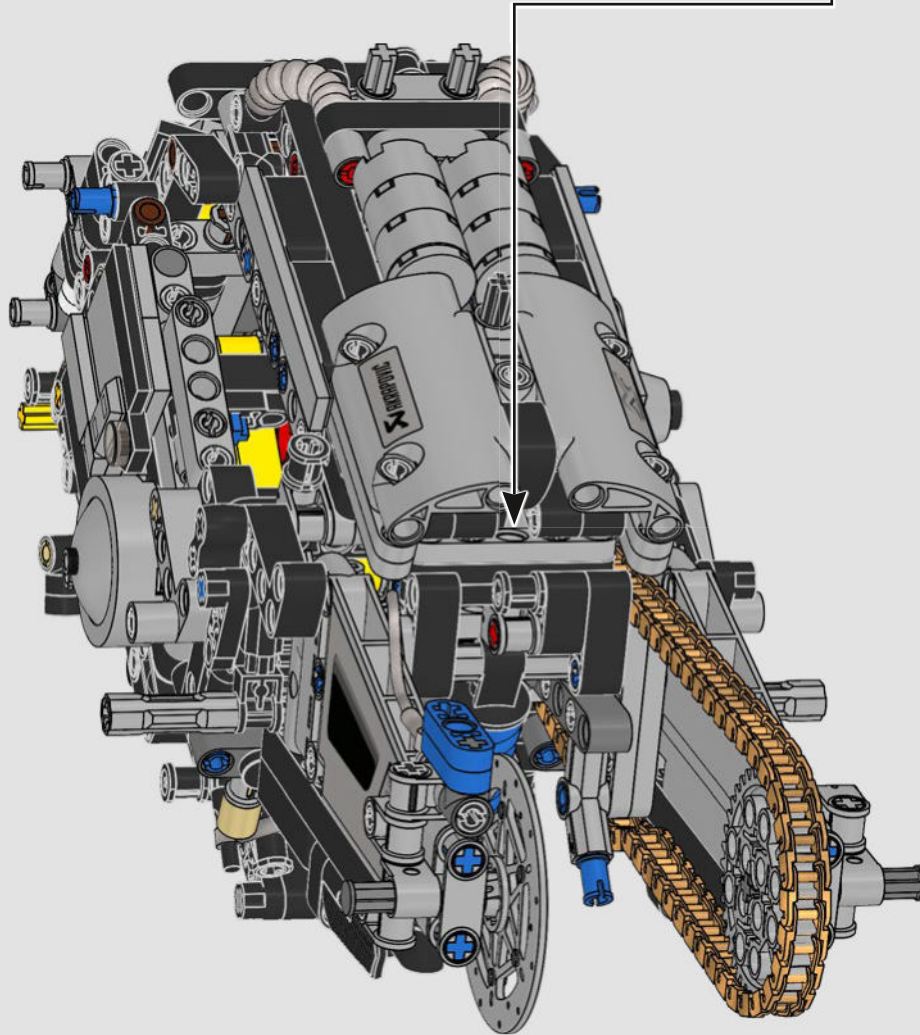
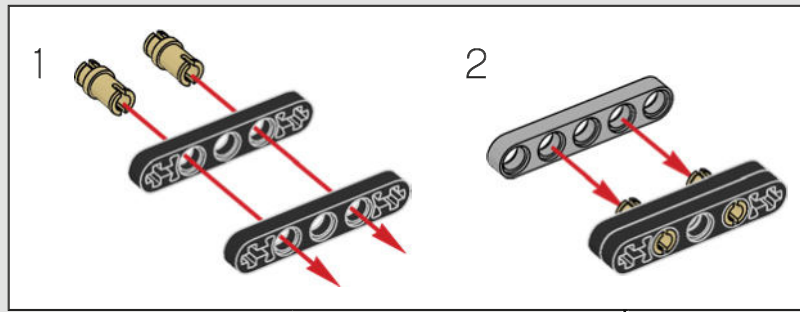

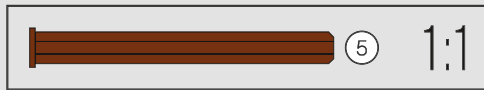
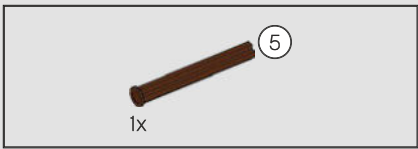

324

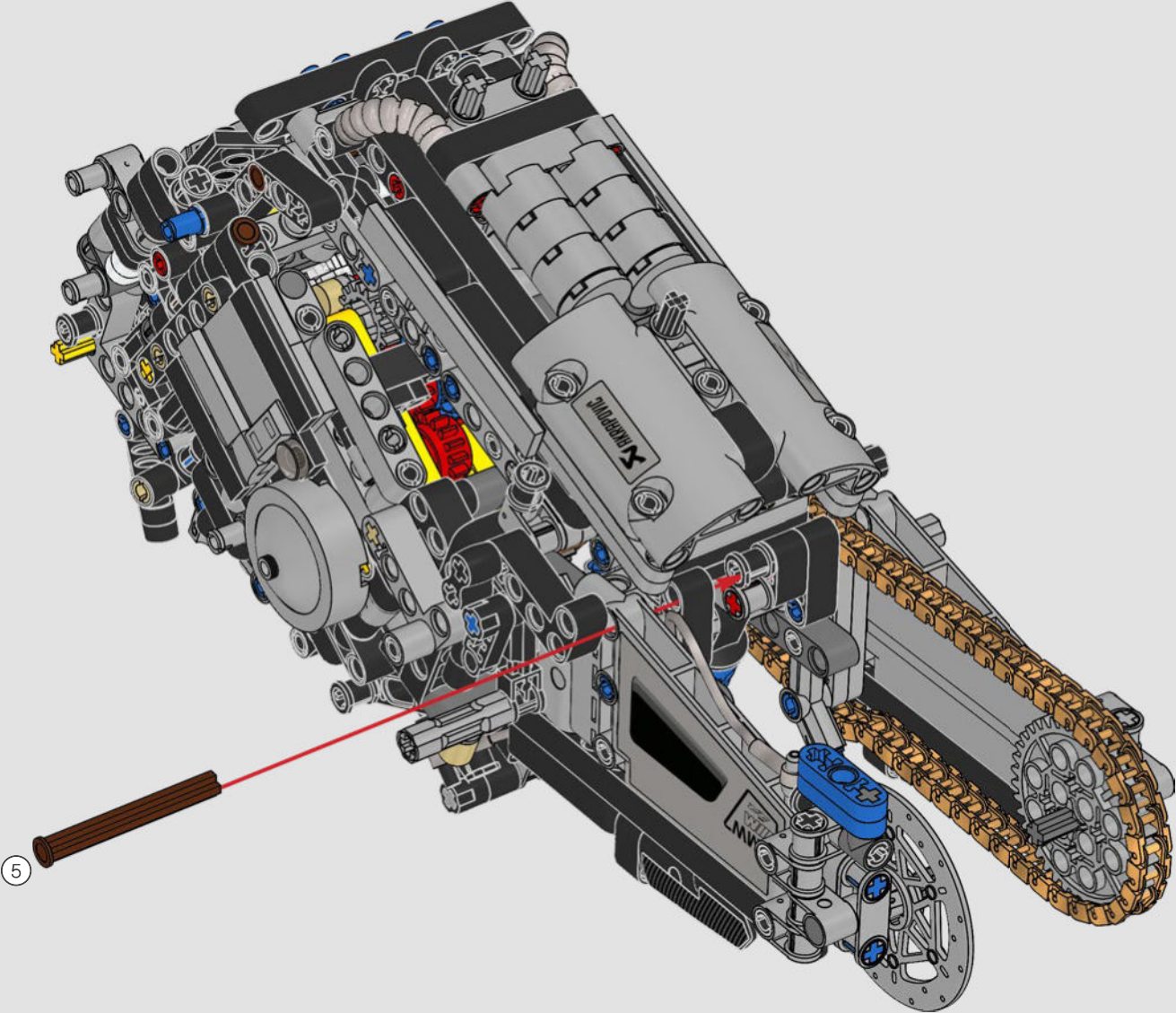

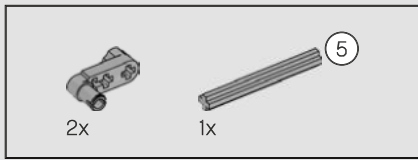

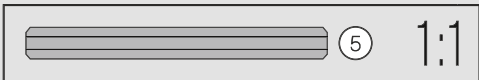
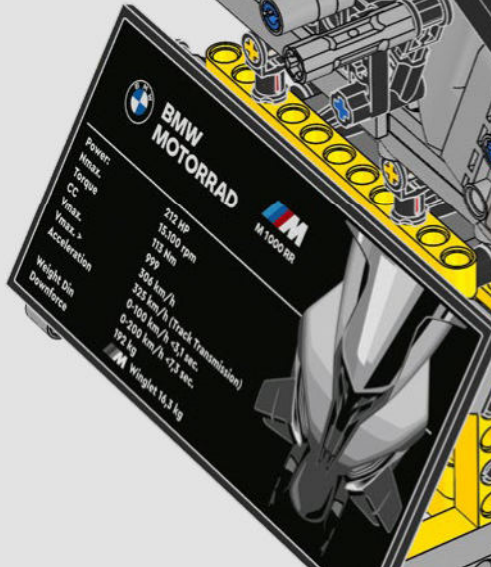
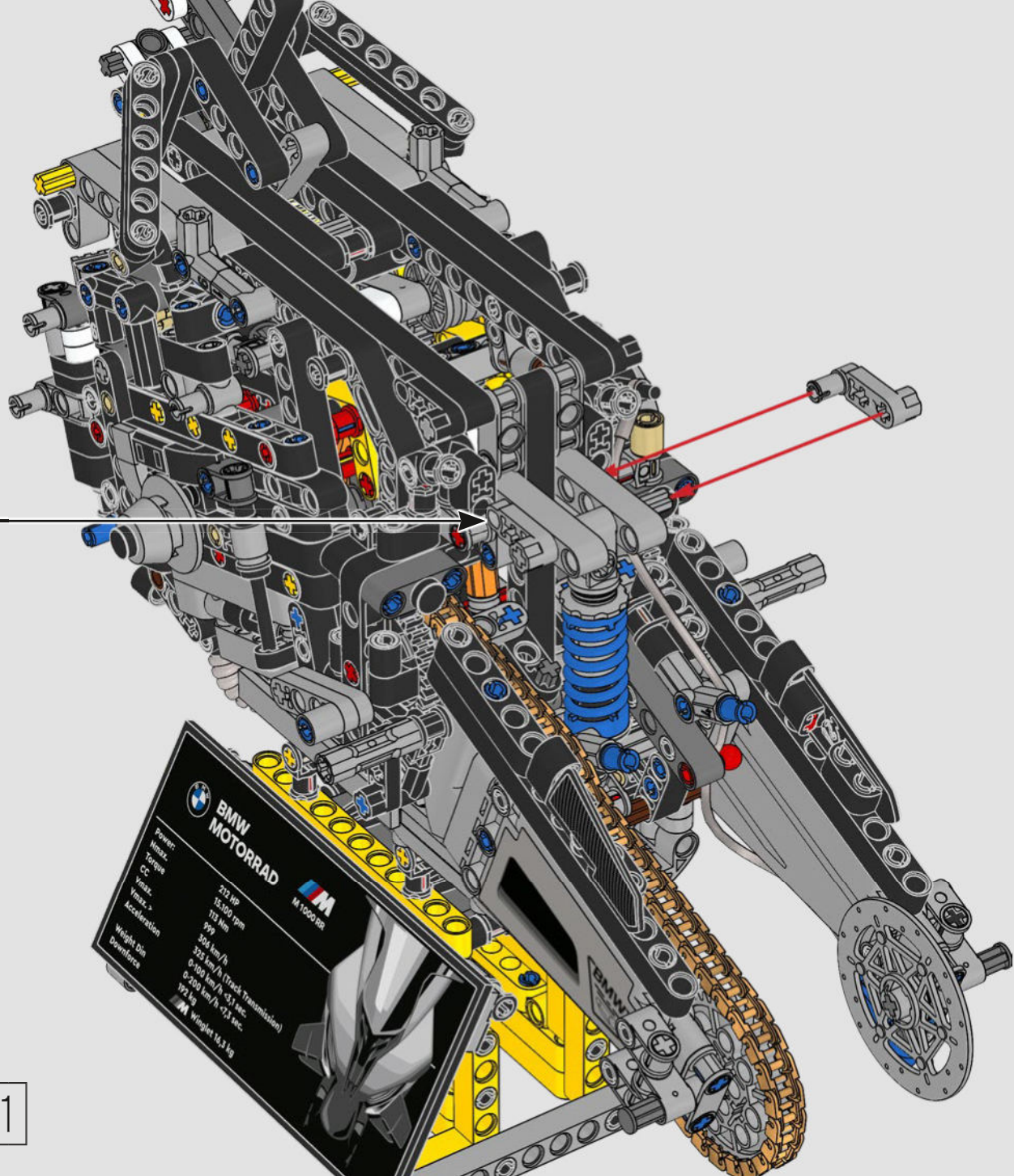
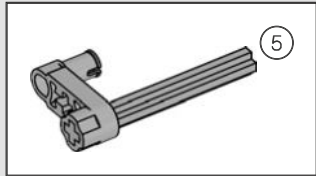

325

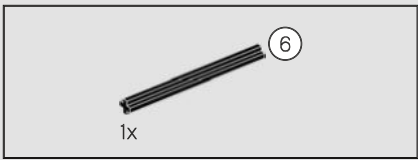

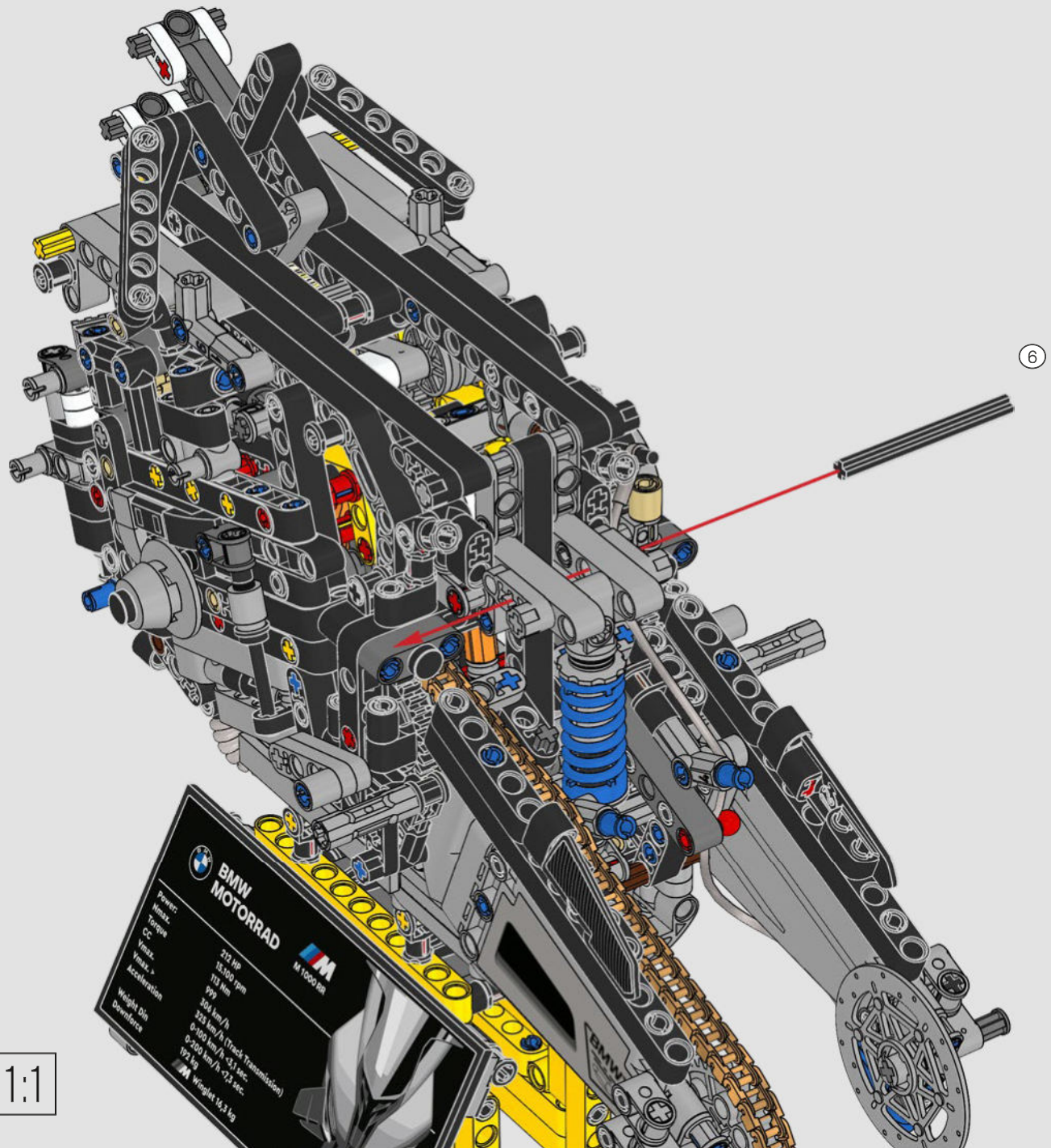

326



BMW MOTORRAD  M 1000 RR

Power	217 HP
Max. torque	15,100 Nm
CC	117 Nm
V _{max}	304 km/h
V _{max} + acceleration	323 km/h (Track transmission)
Weight (Dry)	172 kg
Downforce	0-200 km/h t_{0-1} sec.
	0-200 km/h t_{0-2} sec.
	Weight 14,3 kg

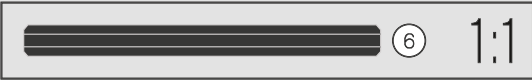



327

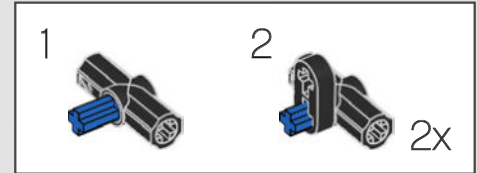
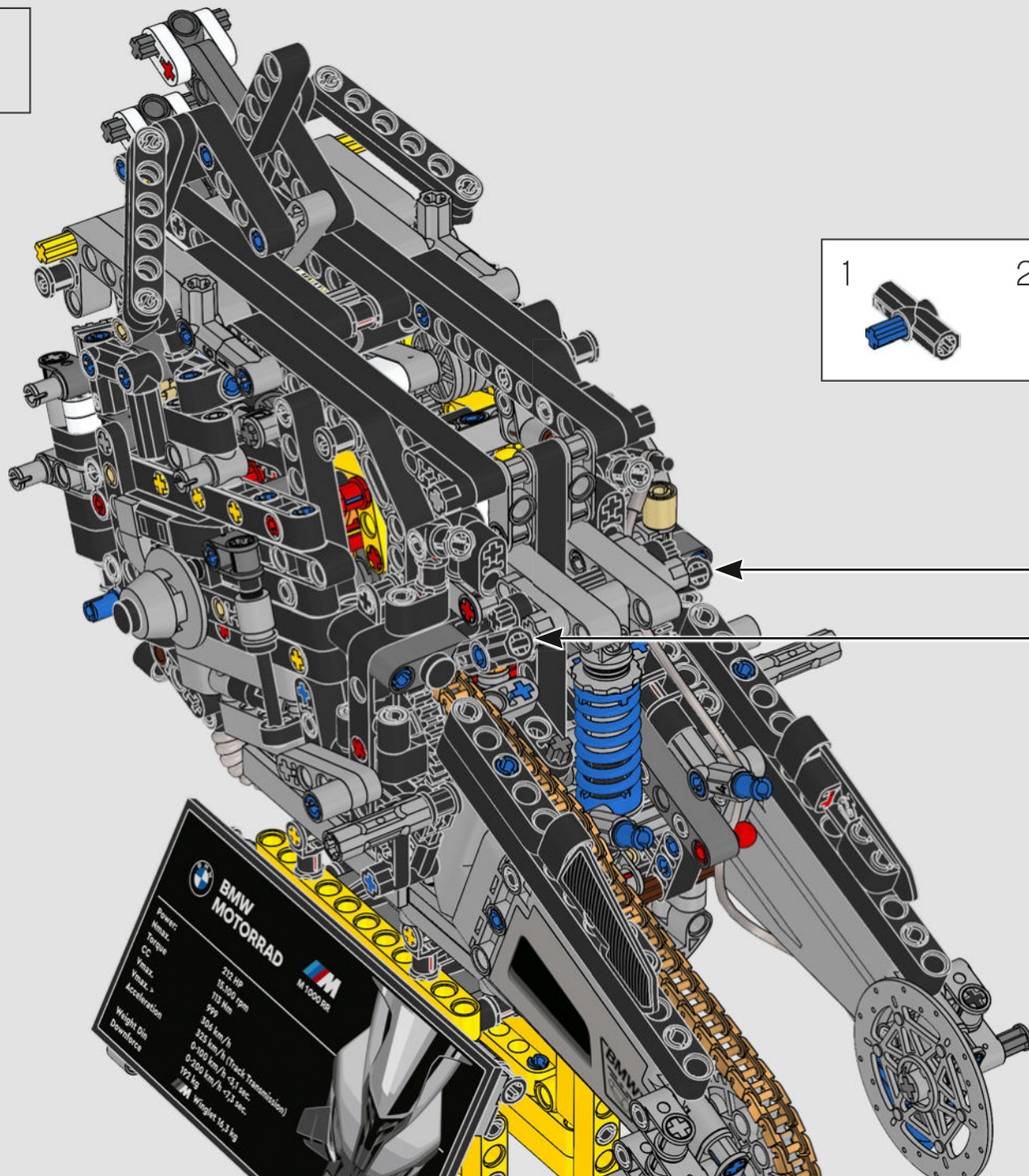

BMW MOTORRAD  **M**
M 1000 RR

Power	212 HP
Max. Torque	12.500 rpm
CC	1170 cm ³
Max. Vmax.	199 km/h
Max. acceleration	3.04 km/h/s
Weight (incl. Downforce)	223 kg (197 kg)
0-100 km/h (Street Transmission)	2.3 sec.
0-200 km/h	7.3 sec.
100-0 km/h	1.3 sec.

BMW **Winglet 14.3 kg**

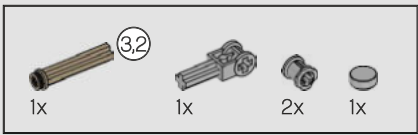

328

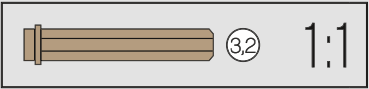
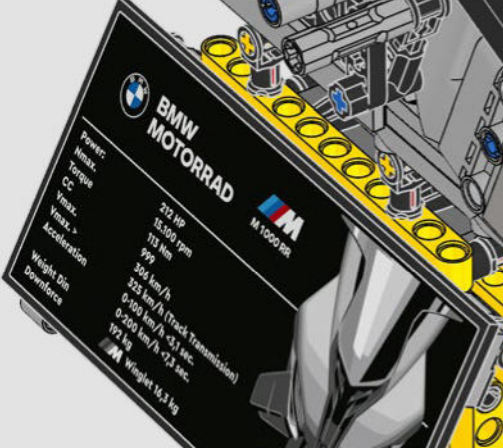
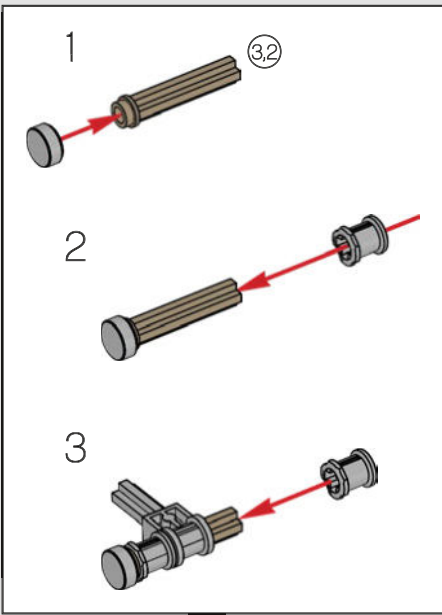
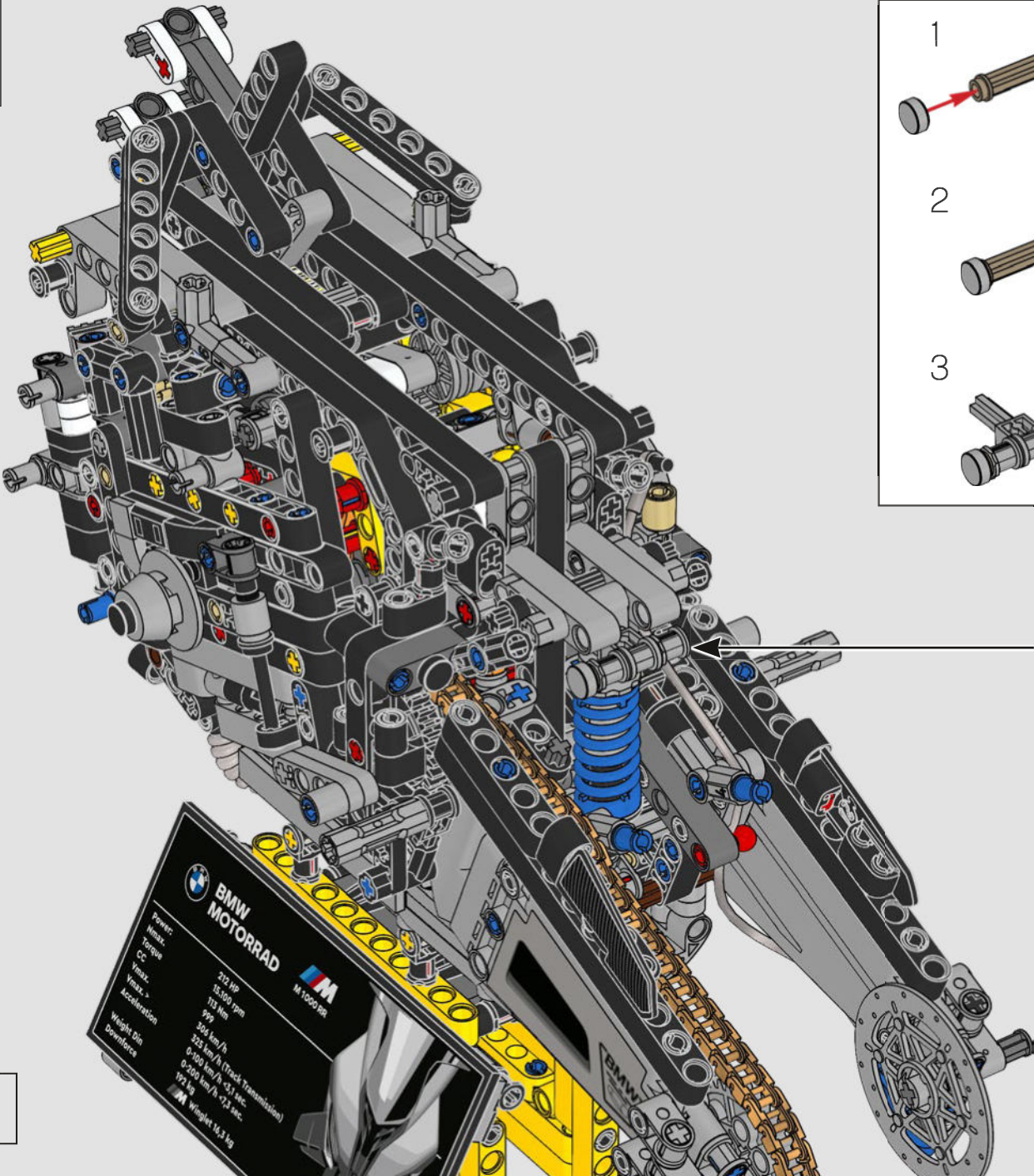

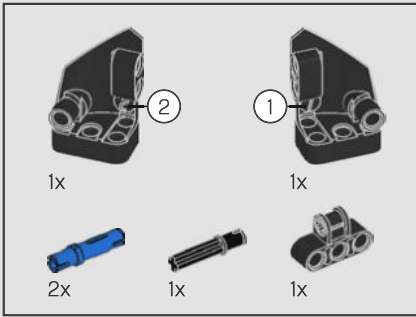

329

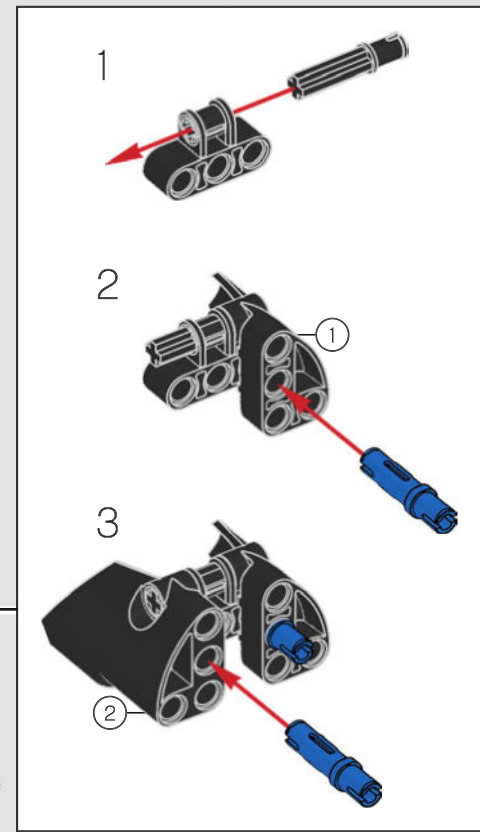
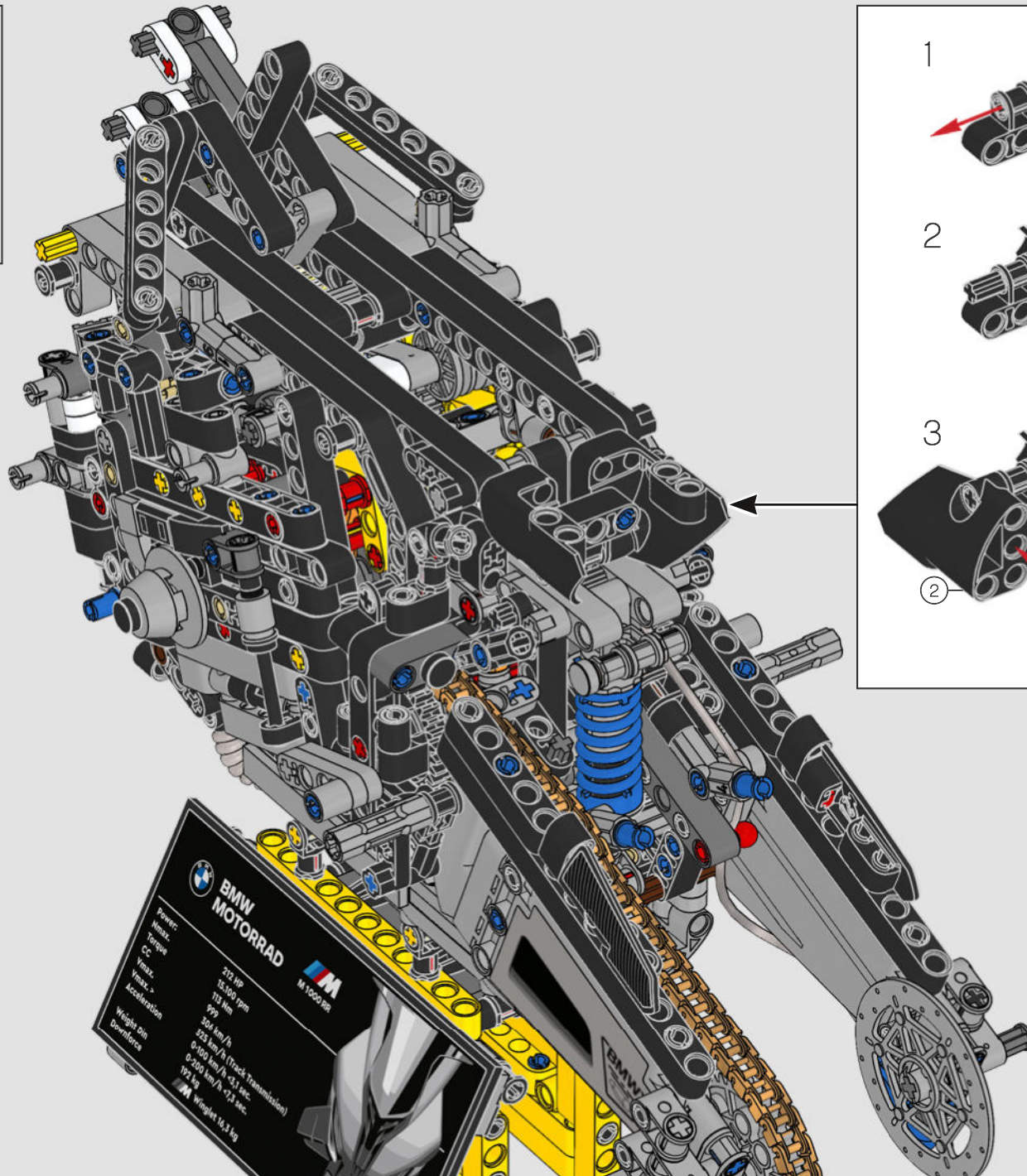

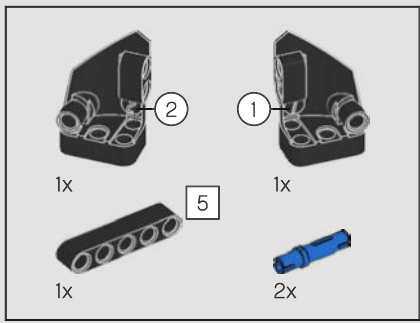

BMW MOTORRAD		M 1000 R
Power:	213 HP	
Max. Torque:	15.500 rpm	
CC:	1732 cm ³	
Max. Vmax:	304 km/h	
Vmax:	0-100 km/h (Track Transmission)	0.93 sec.
Acceleration:	0-200 km/h	1.73 sec.
Weight (incl. downforce)	192 kg	
	Winglet 14,3 kg	

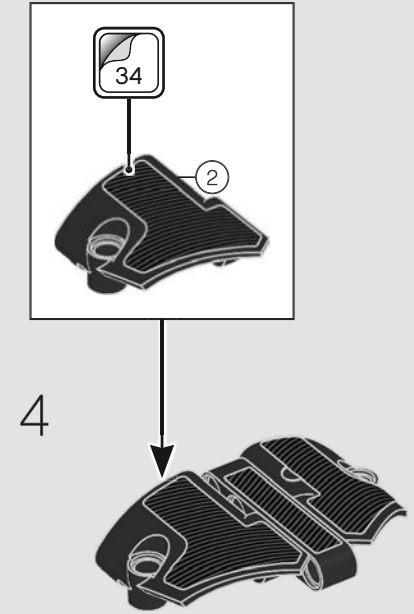
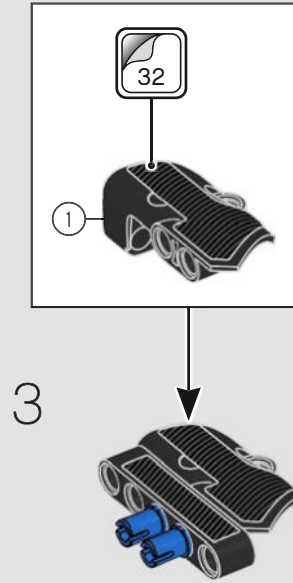
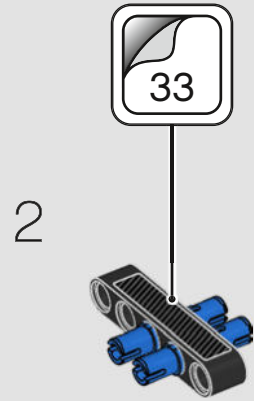
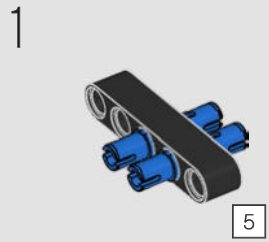

330

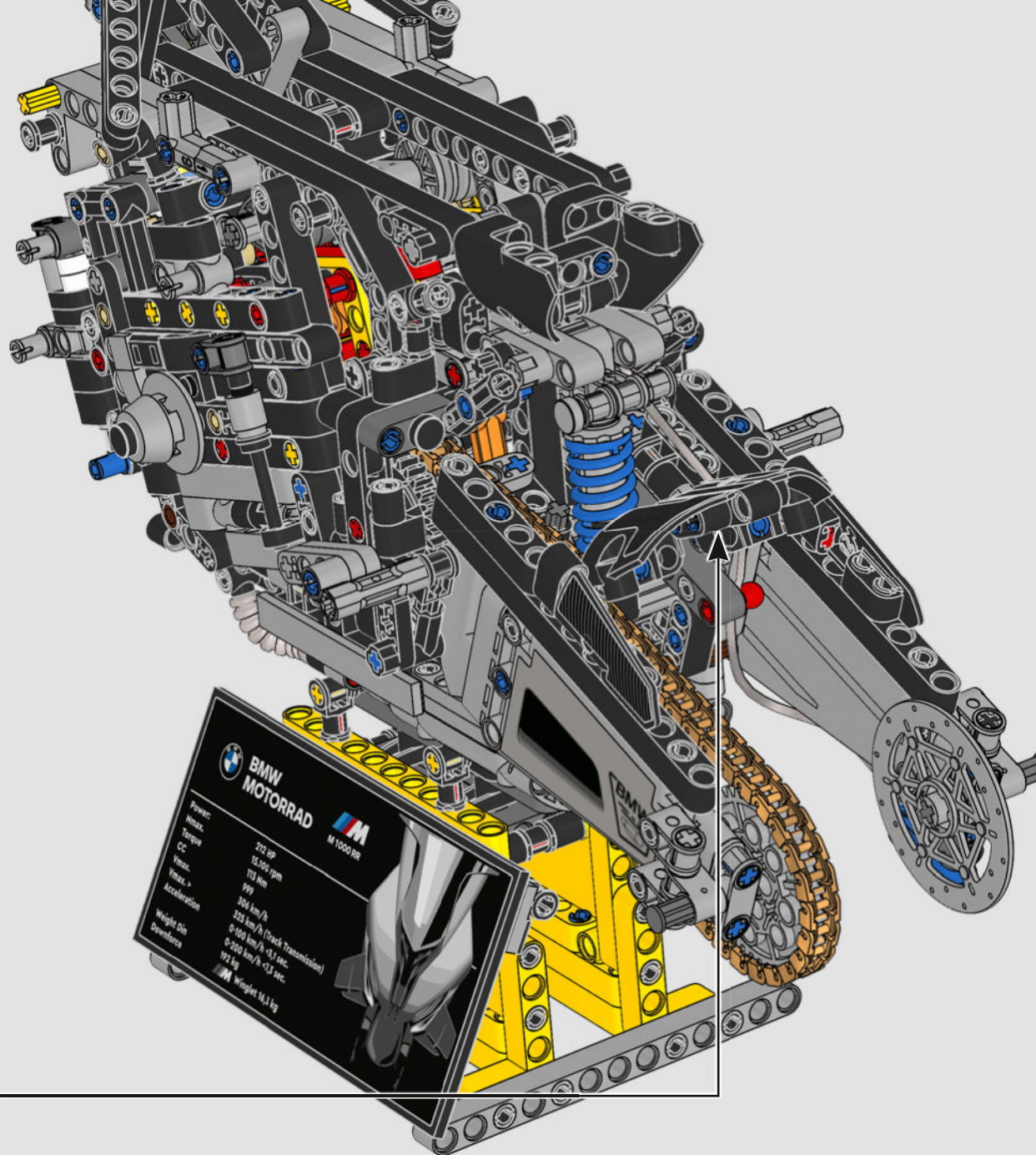



BMW MOTORRAD 
M 1000R

Power: 212 HP
Torque: 15.567 rpm
CC: 113 Nm
Vmax: 324 km/h
Vmax + Acceleration: 325 km/h (Track Transmission)
Weight Dry: 0-100 km/h 3.1 sec
Downforce: 0-200 km/h 0.1 sec
Weight 16.1 kg

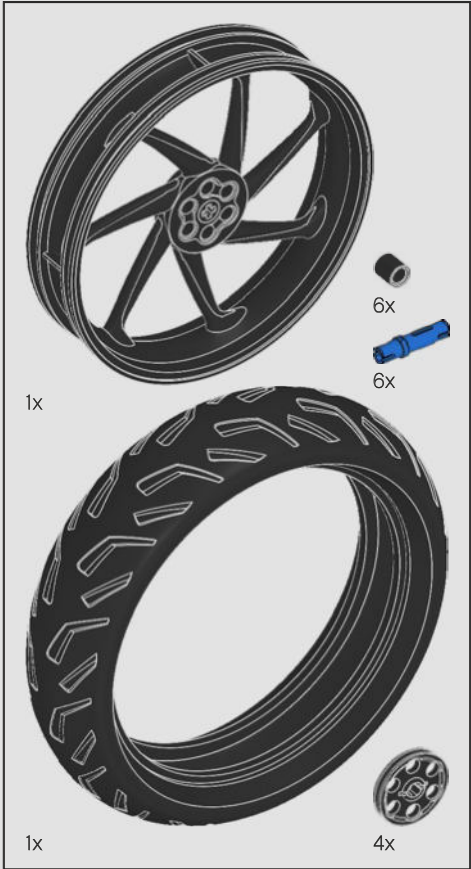

1

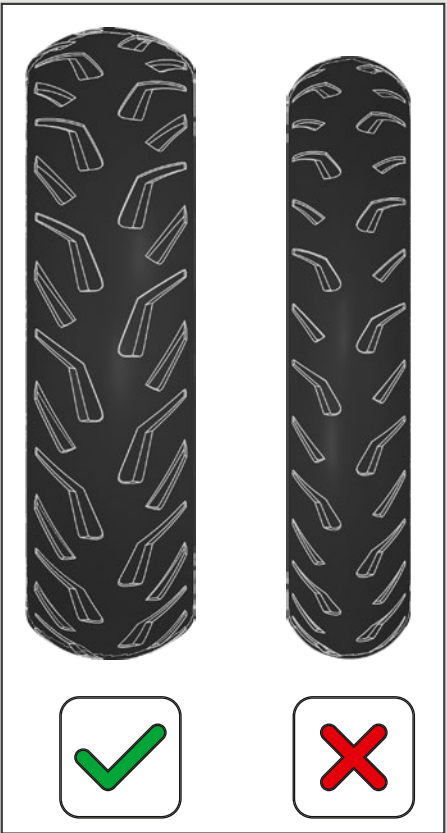

331

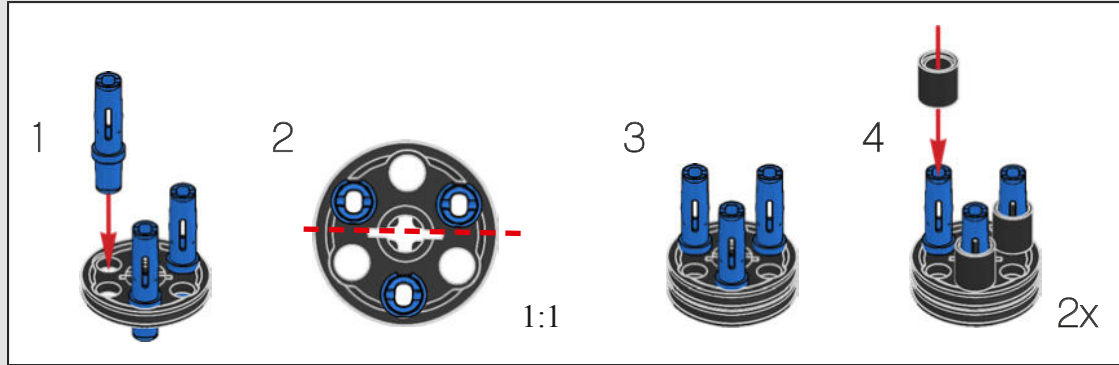

2

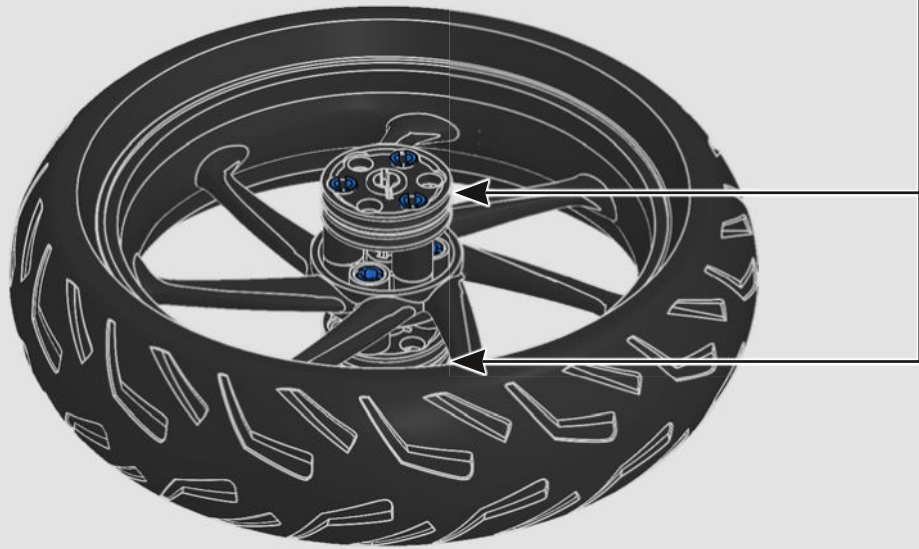

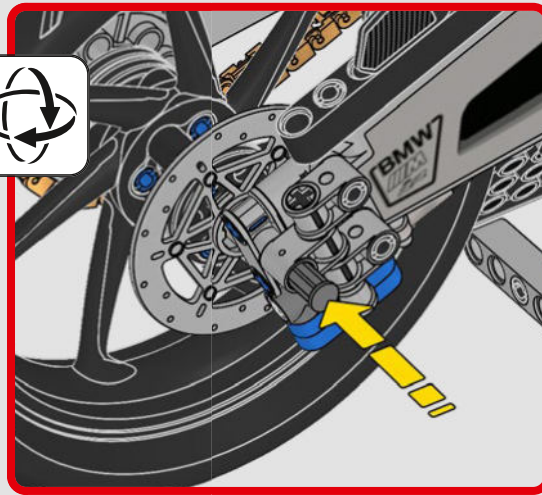
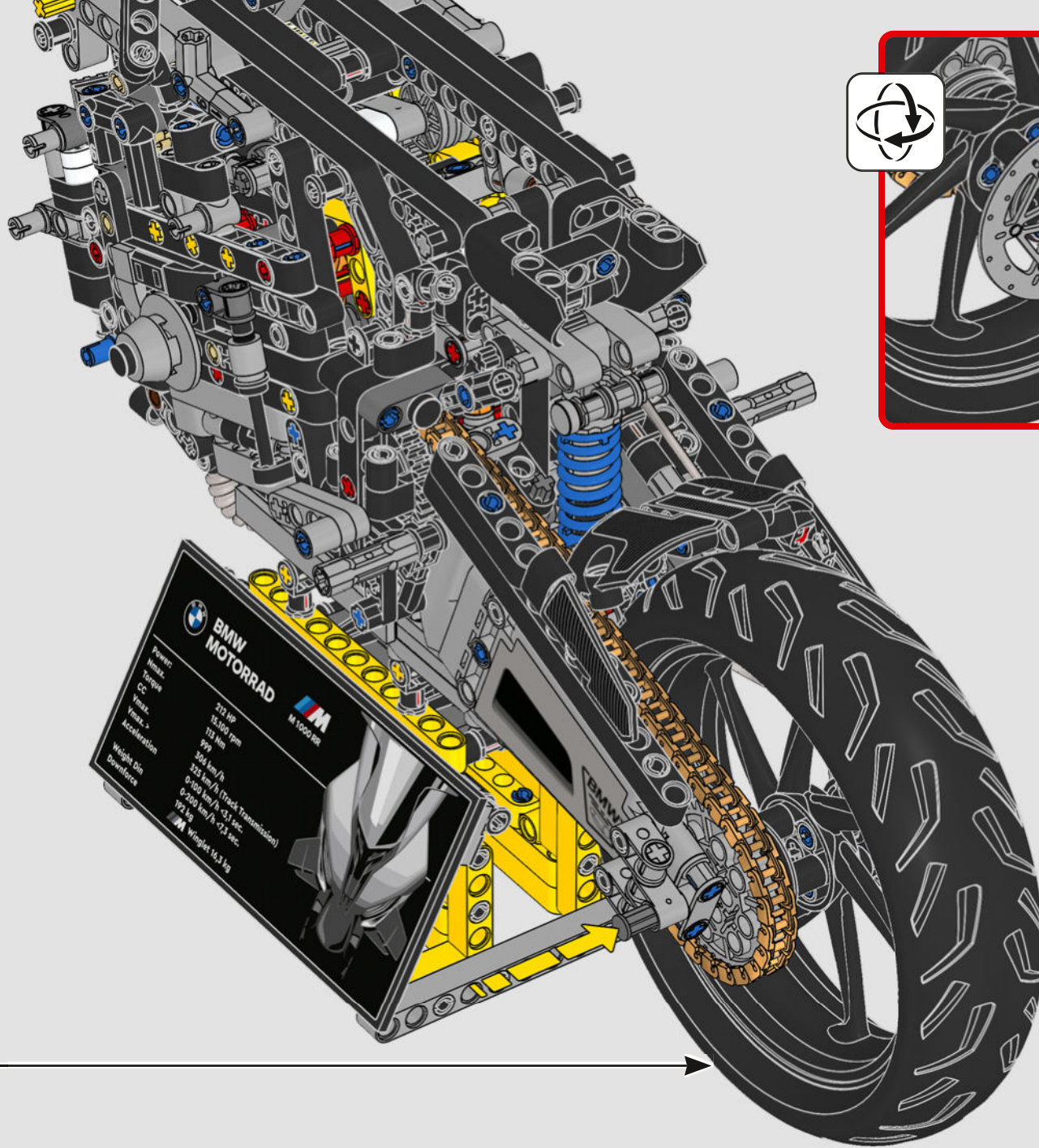

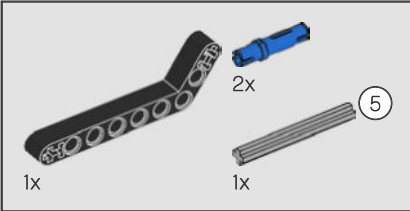
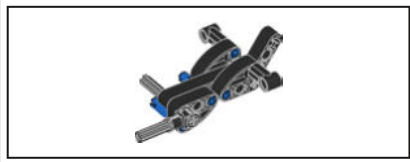

332

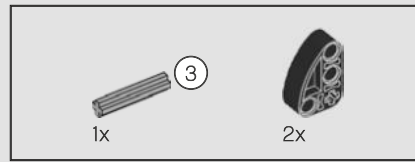
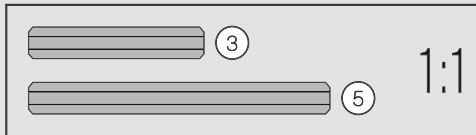
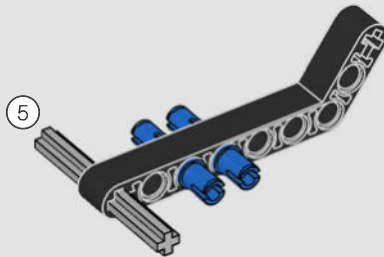

333

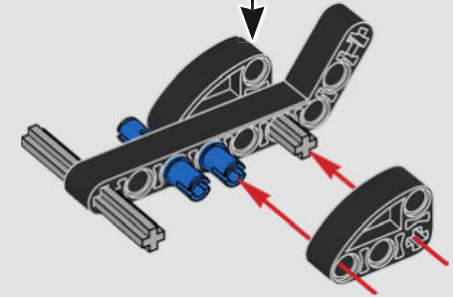
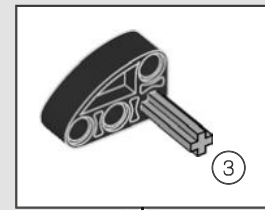

334

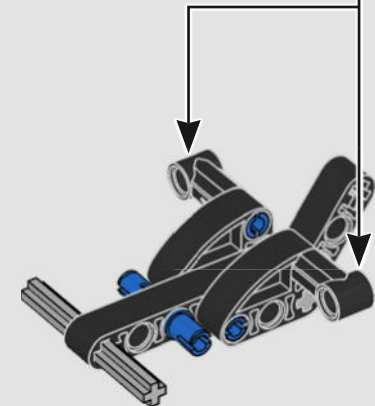

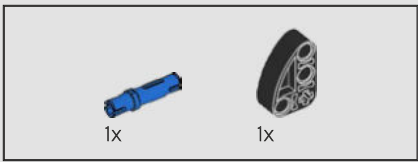

335

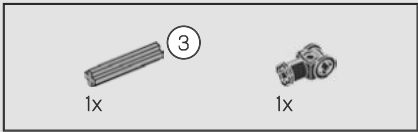
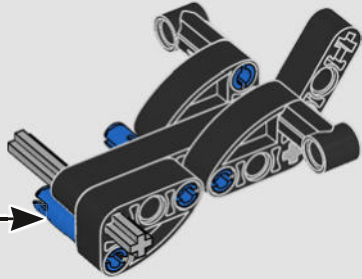

336

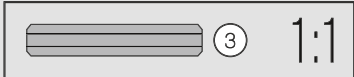
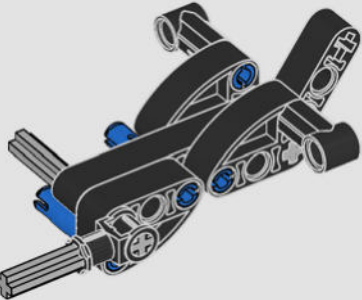
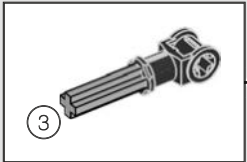

337

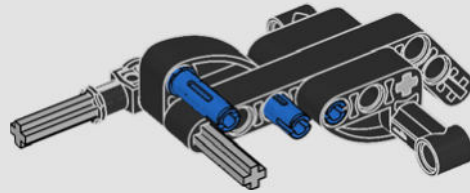

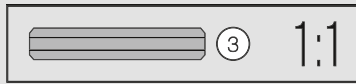
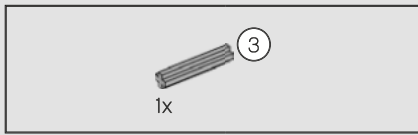

338

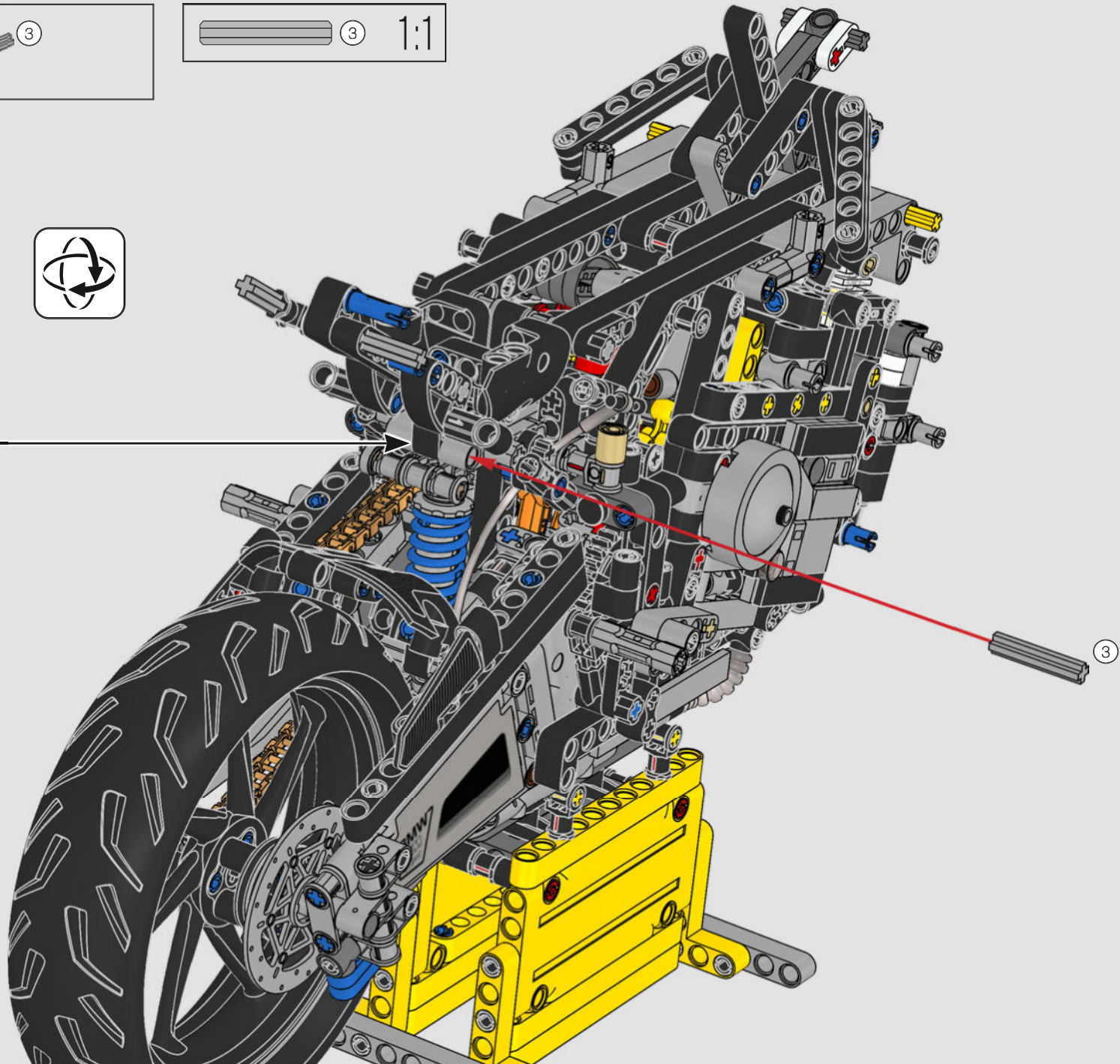

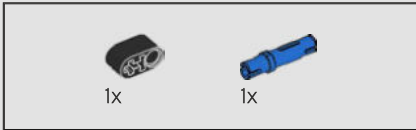
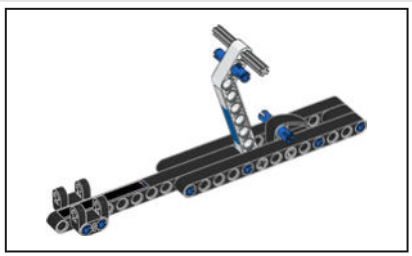

339

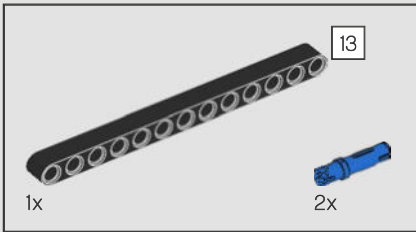

340

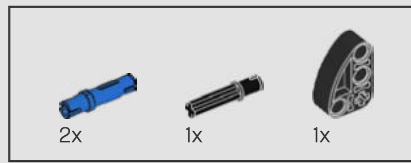
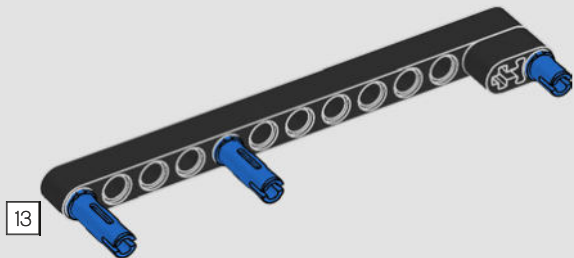

341

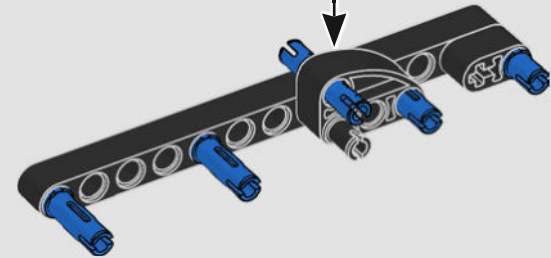
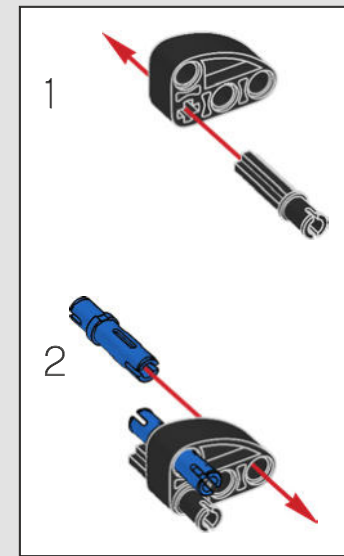

1:1

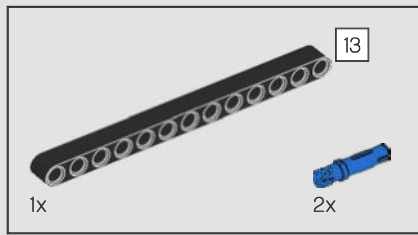

342

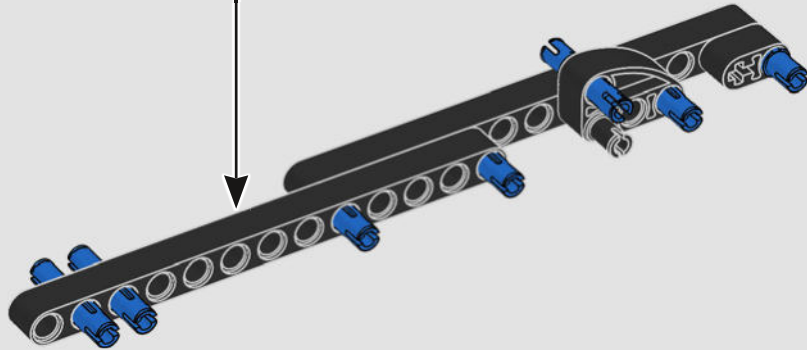
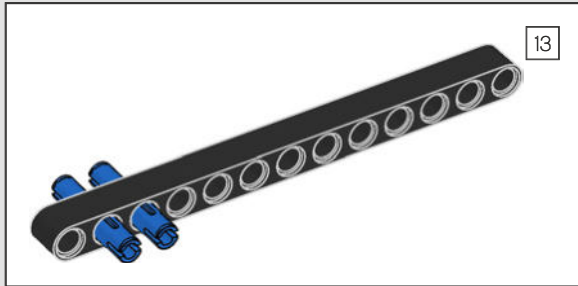

343

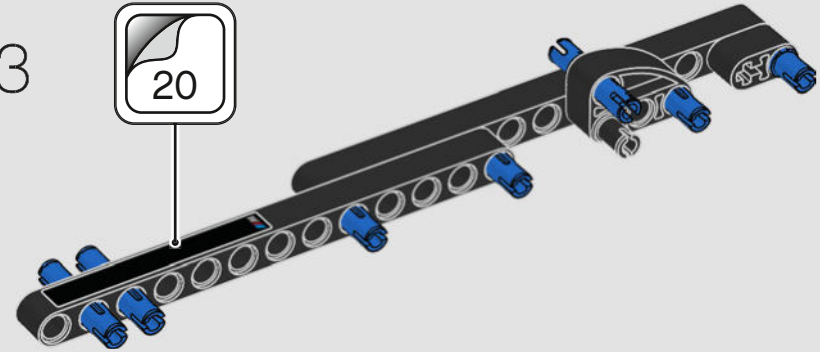

344

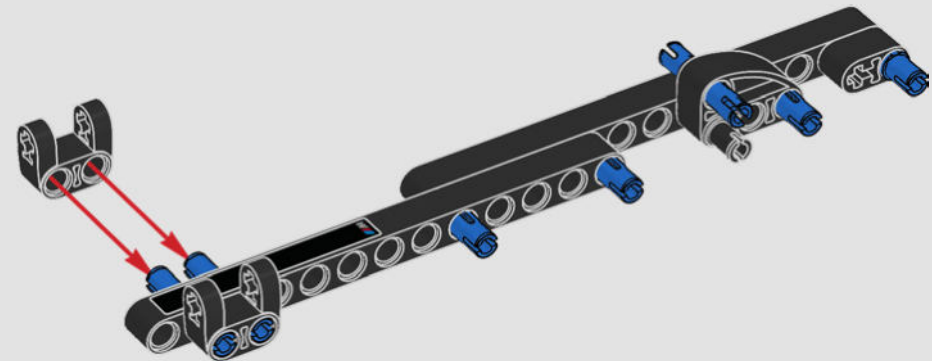

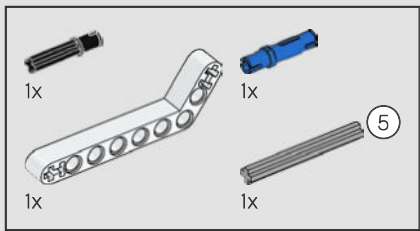

345

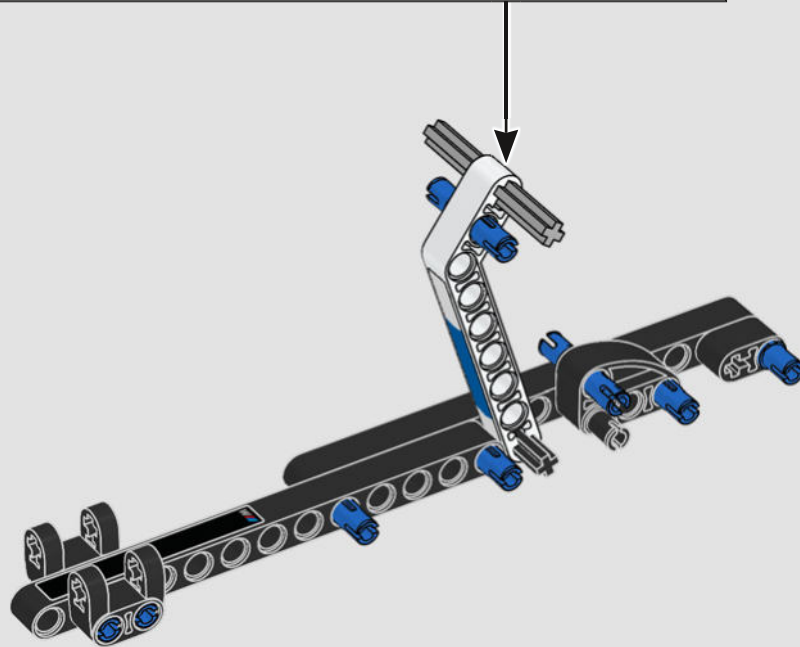
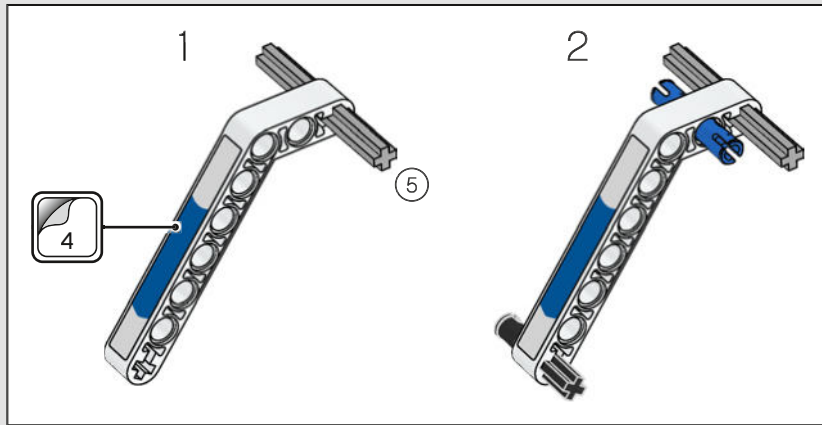
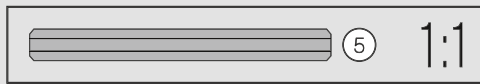

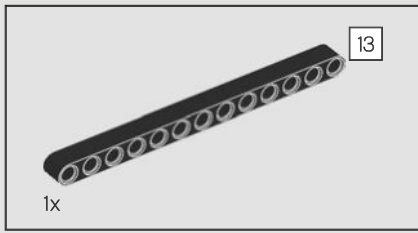

346

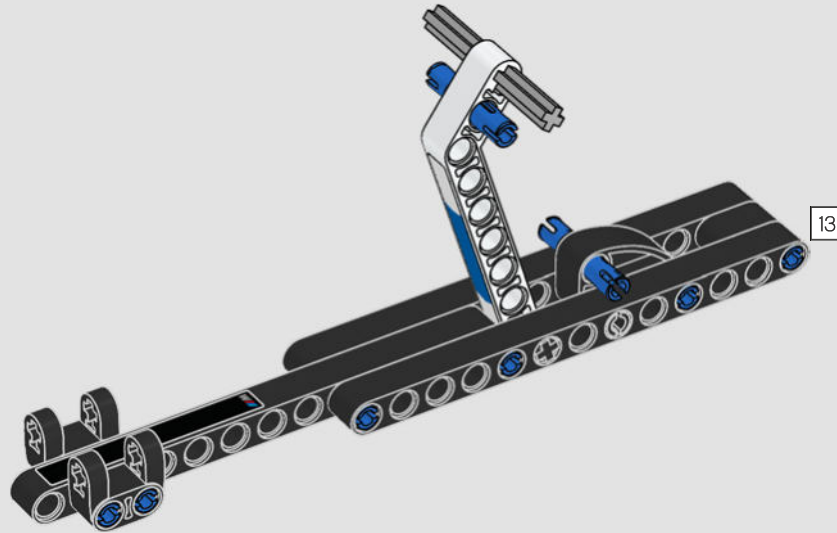

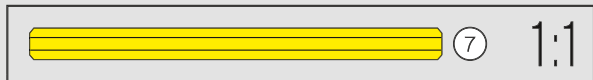
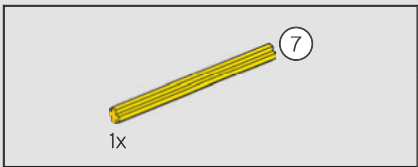

347

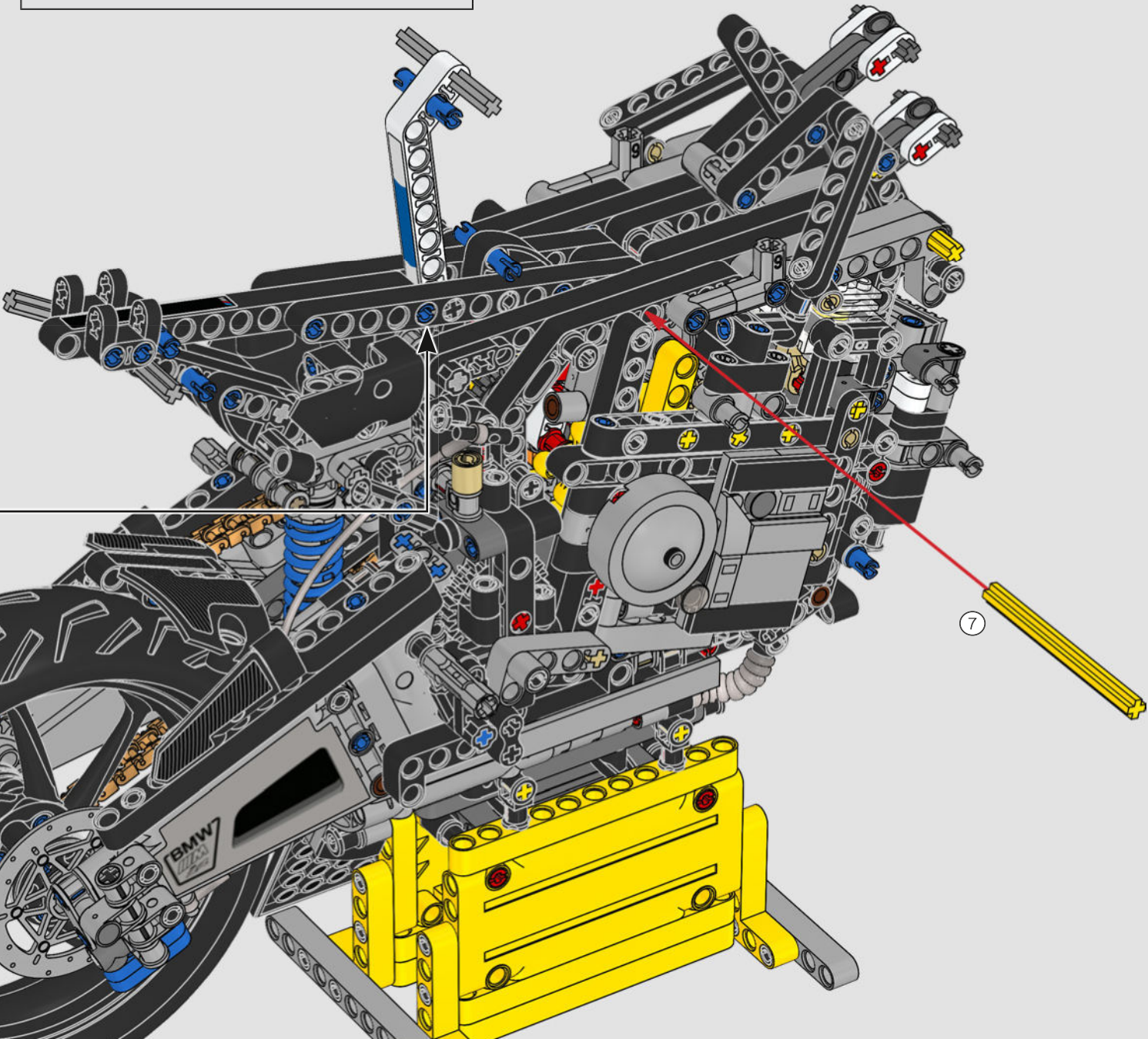
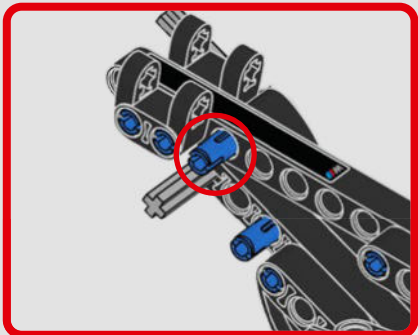

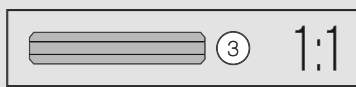

348

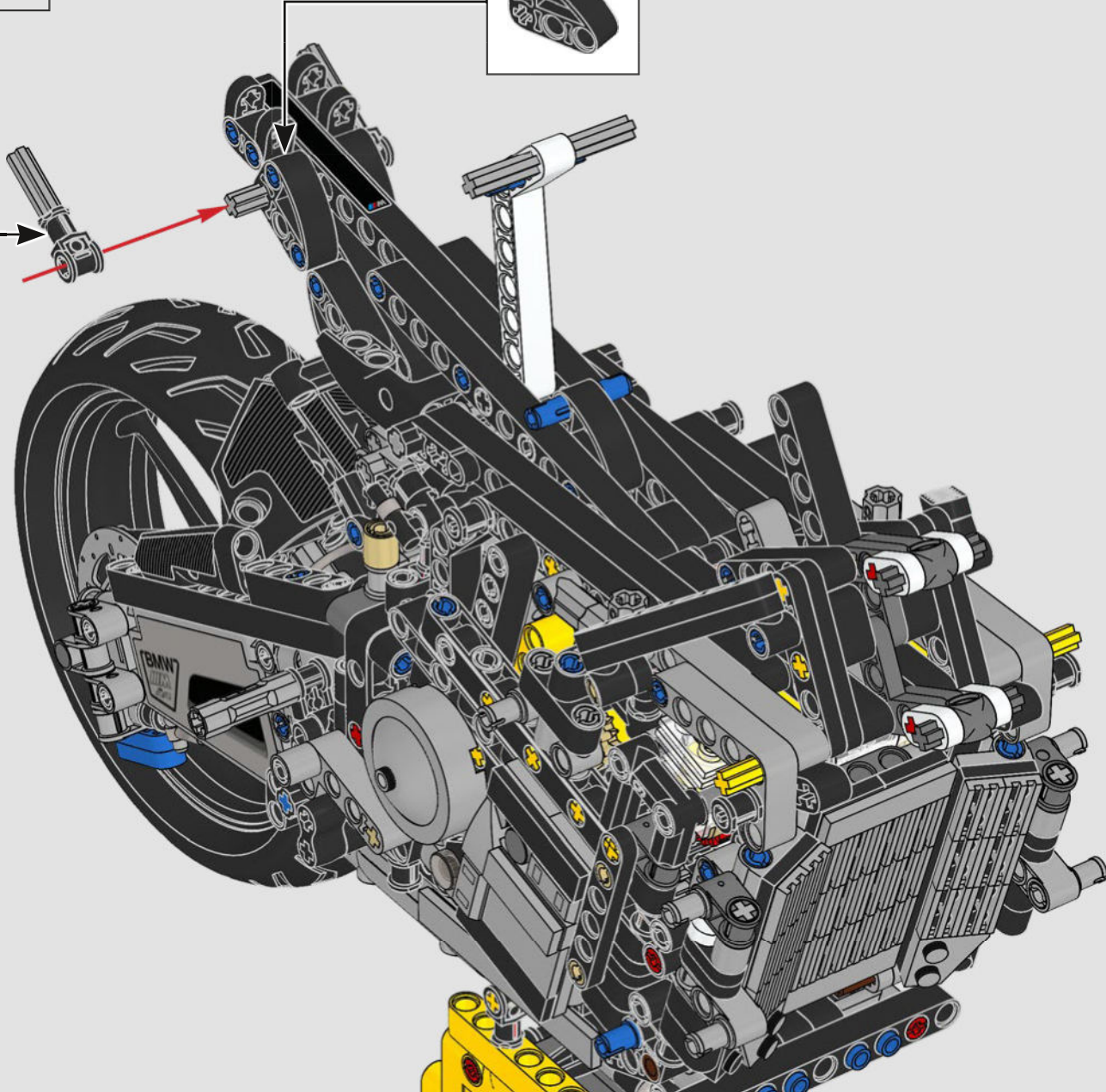
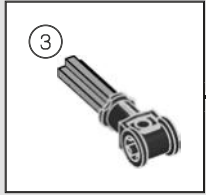

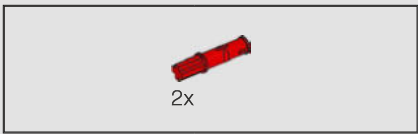

349

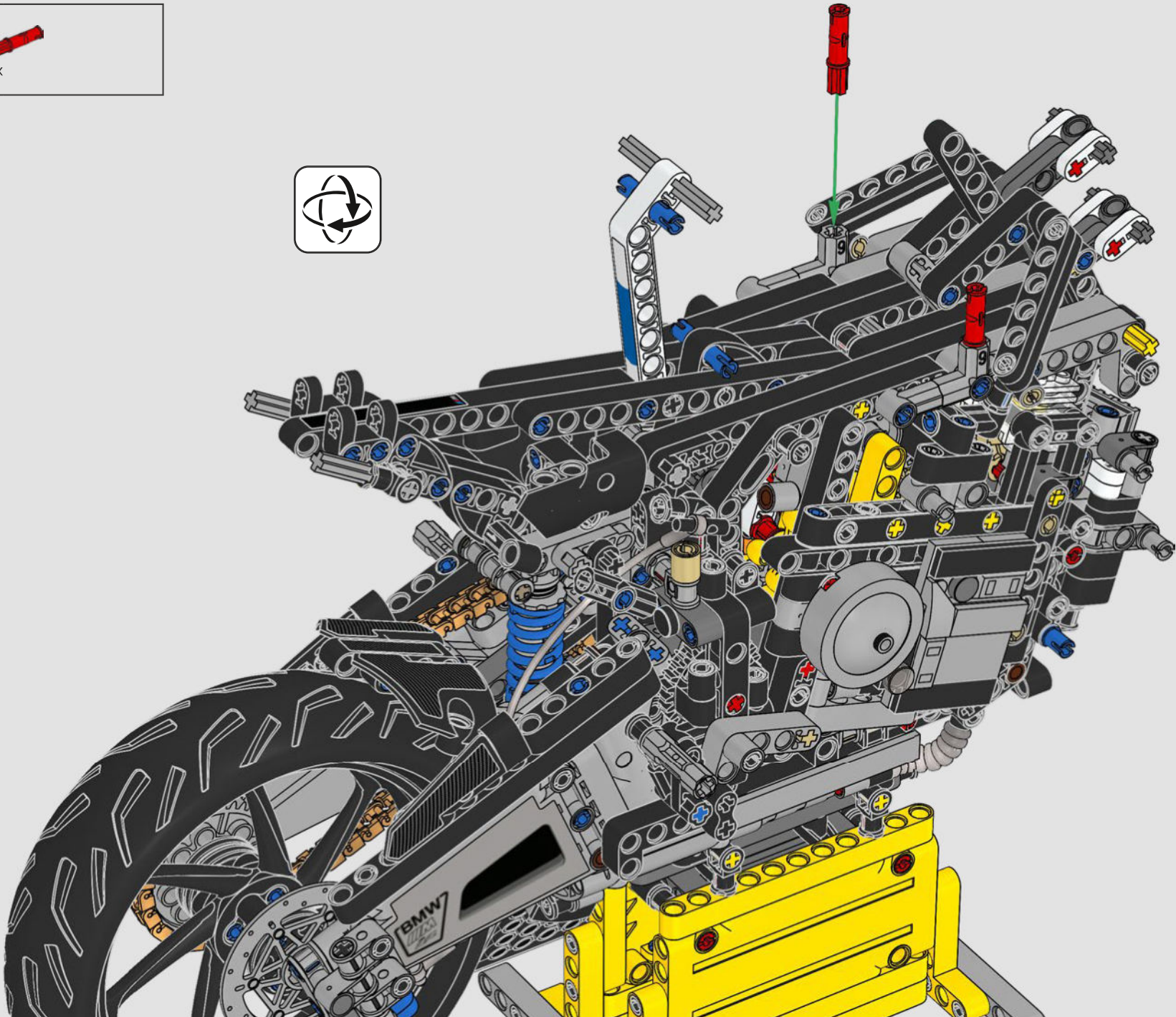

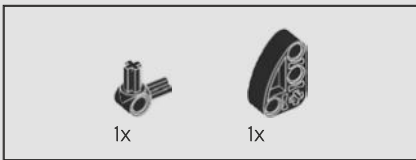

350

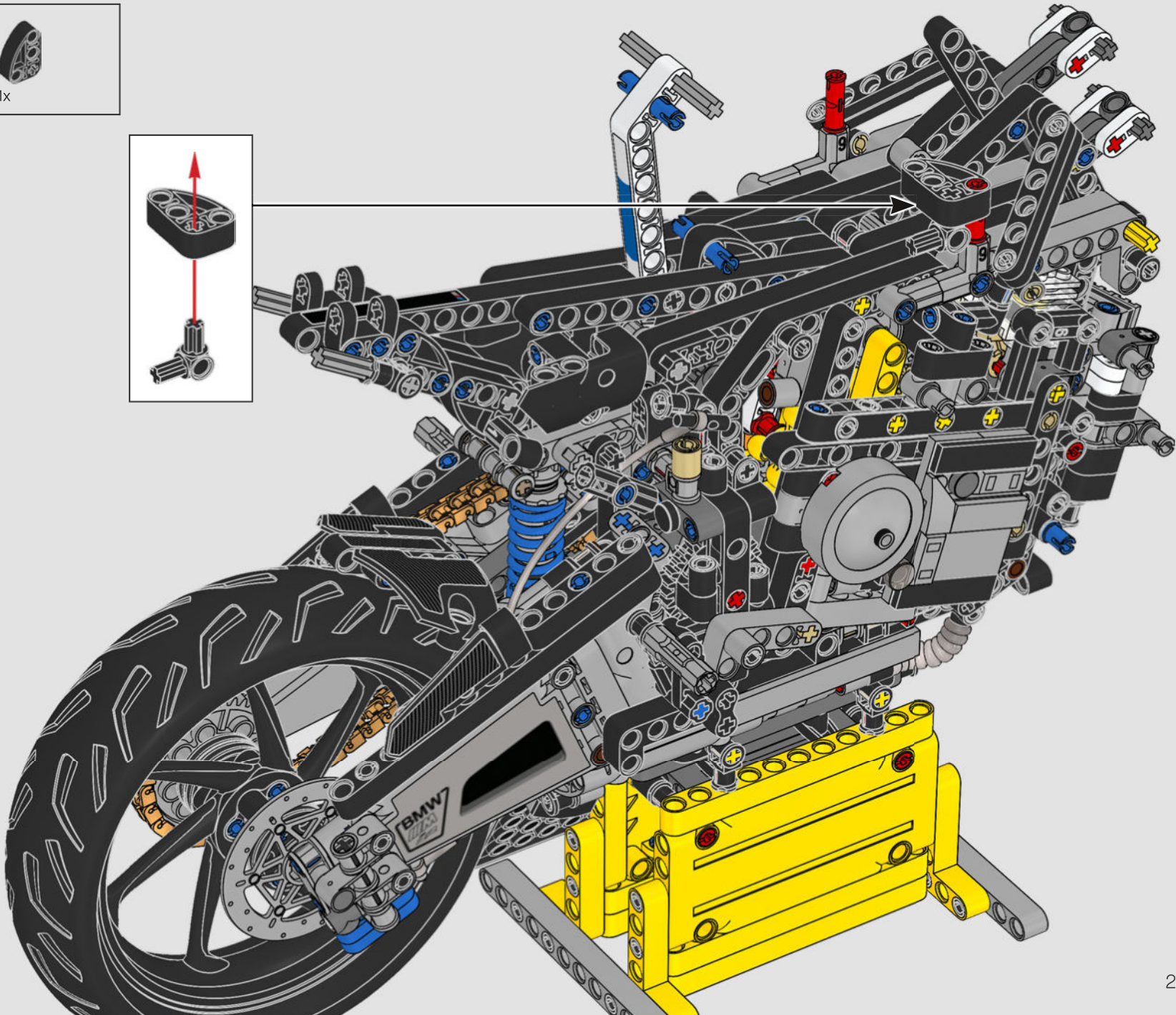
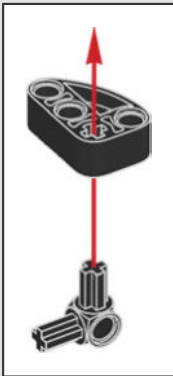

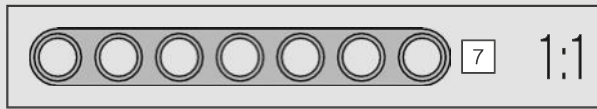
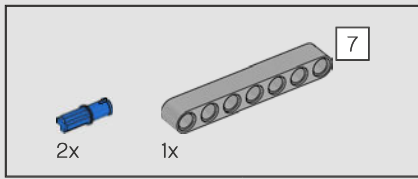

351

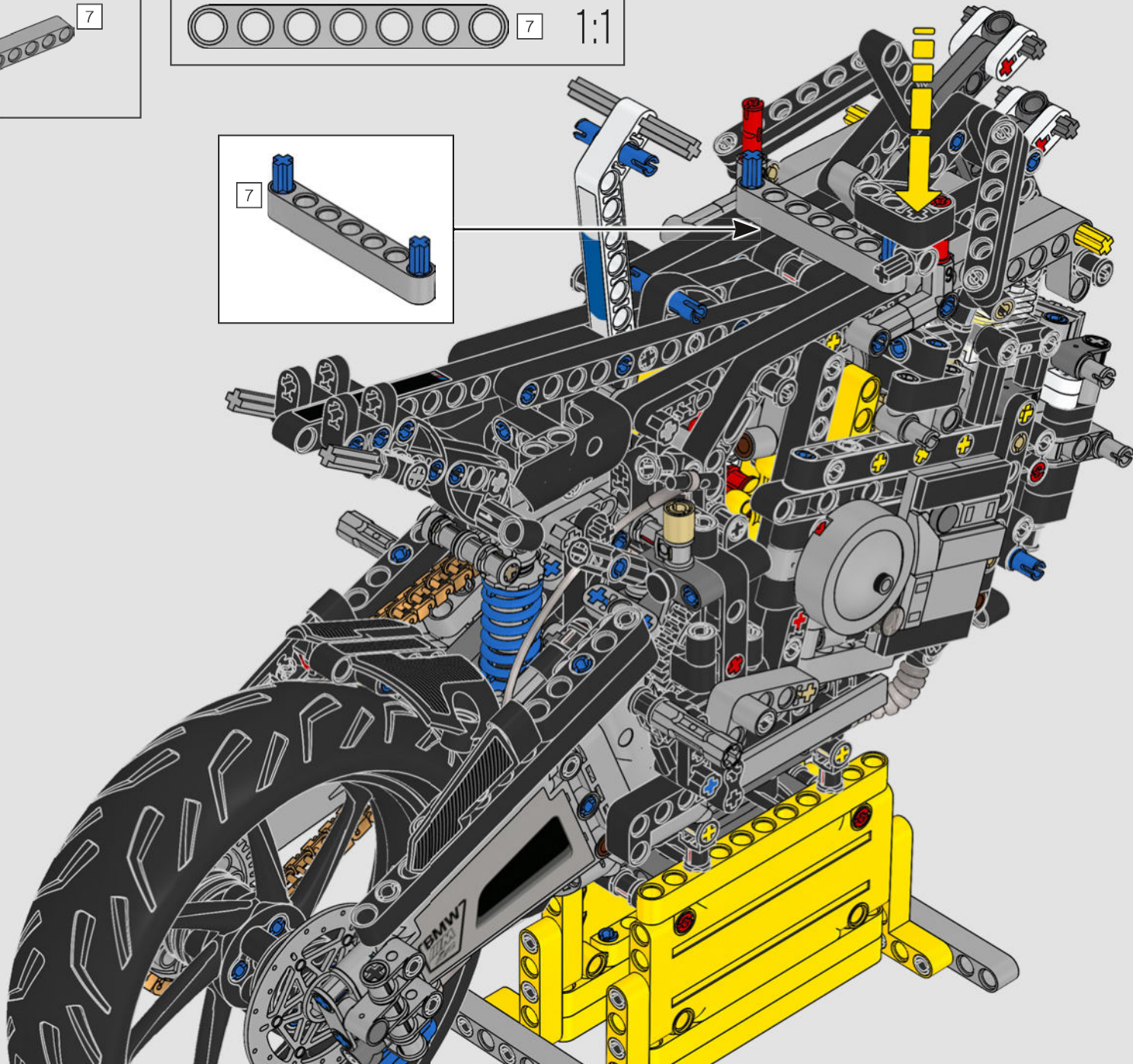
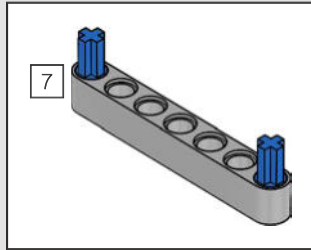

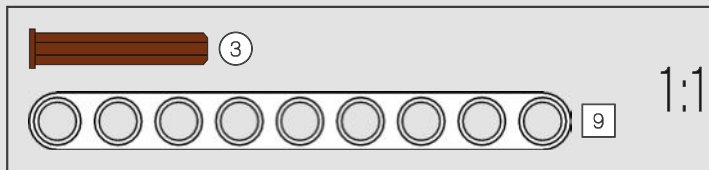
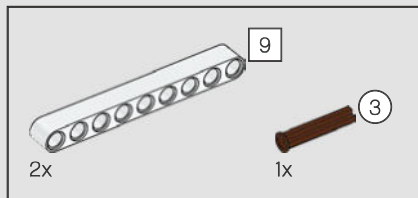

352

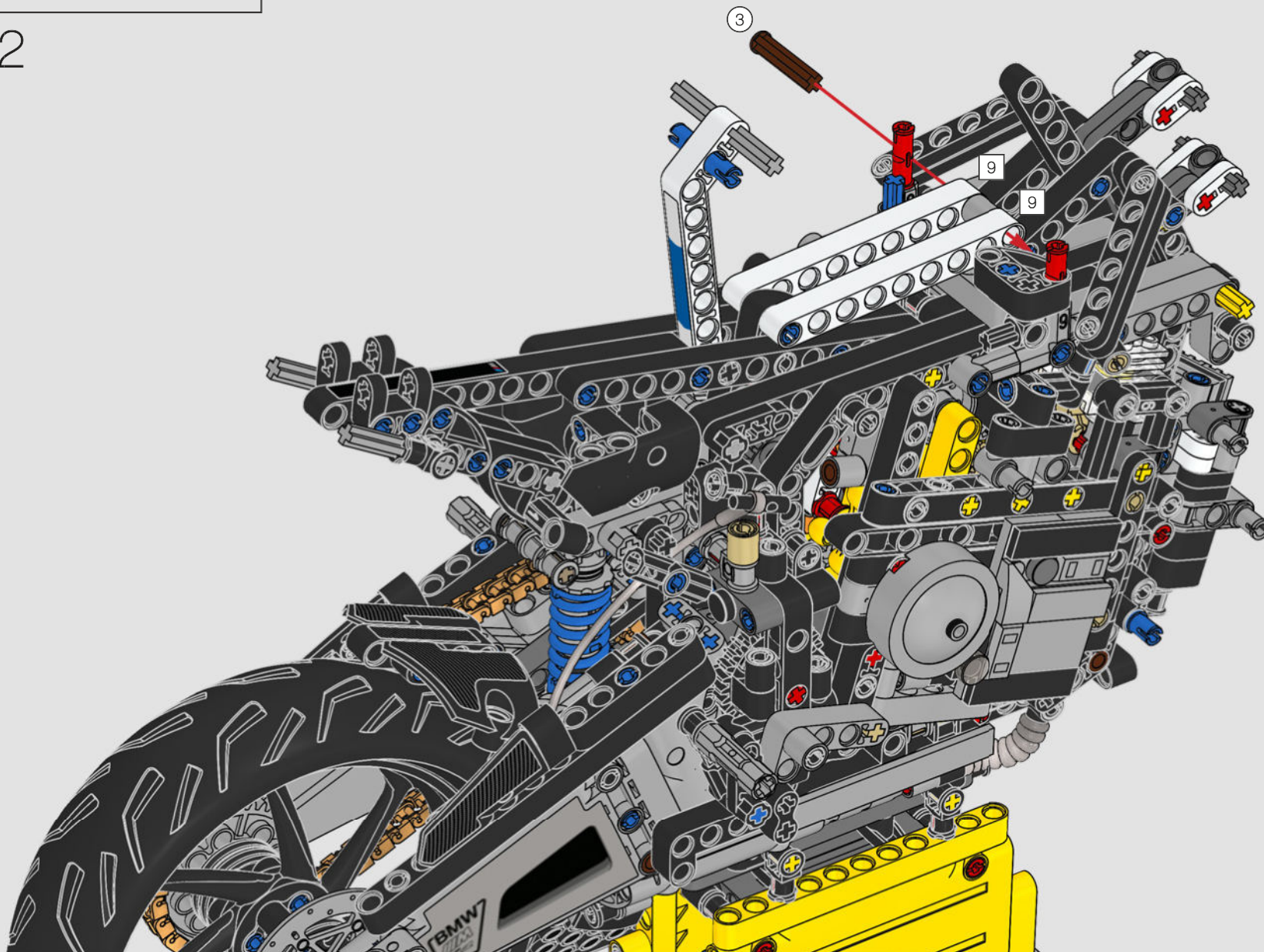

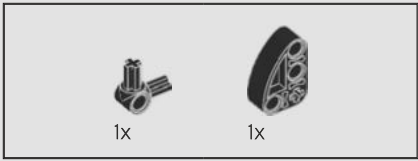

353

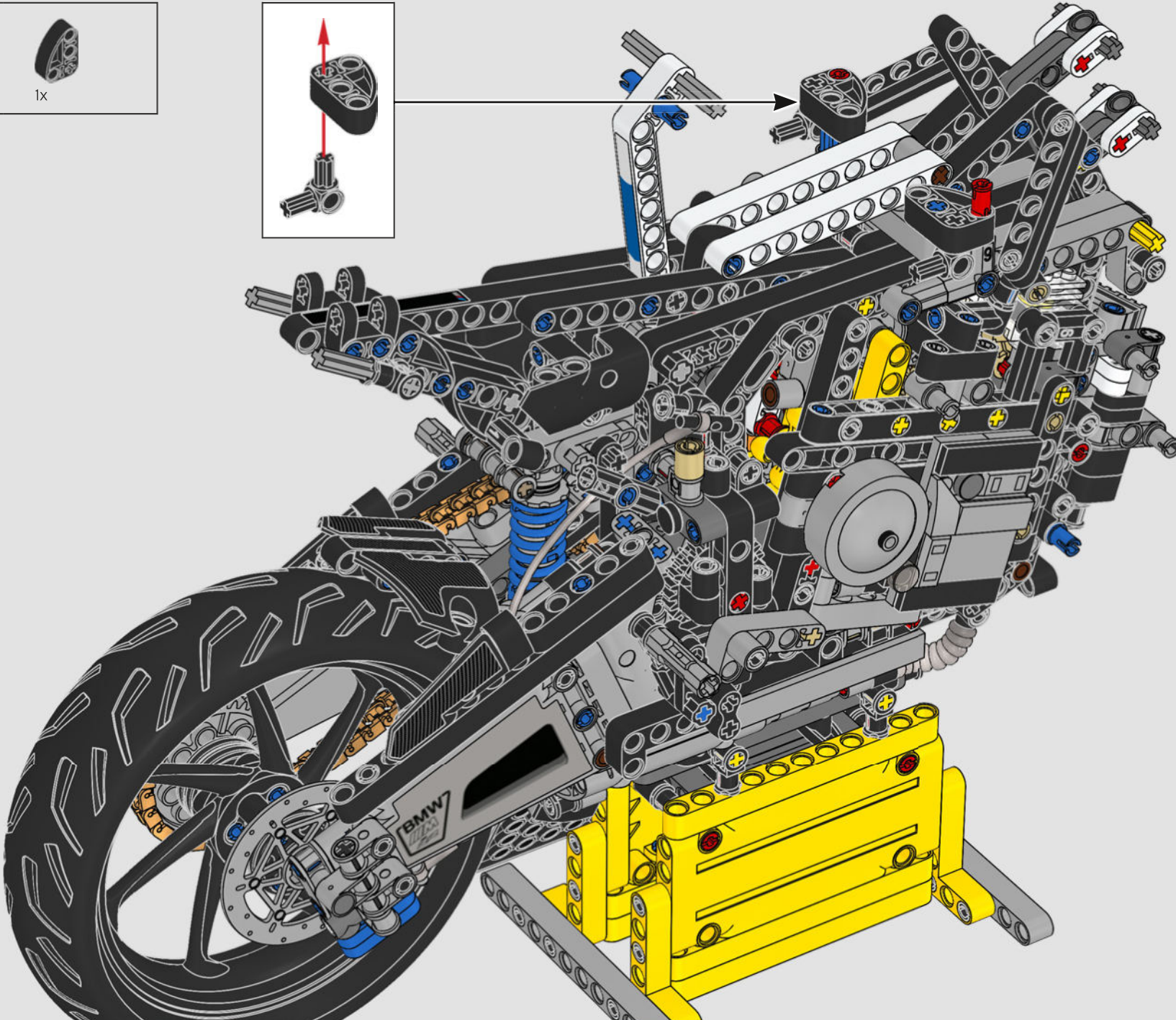
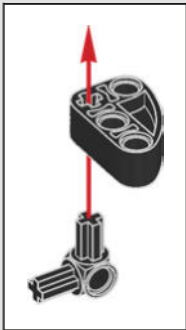



354

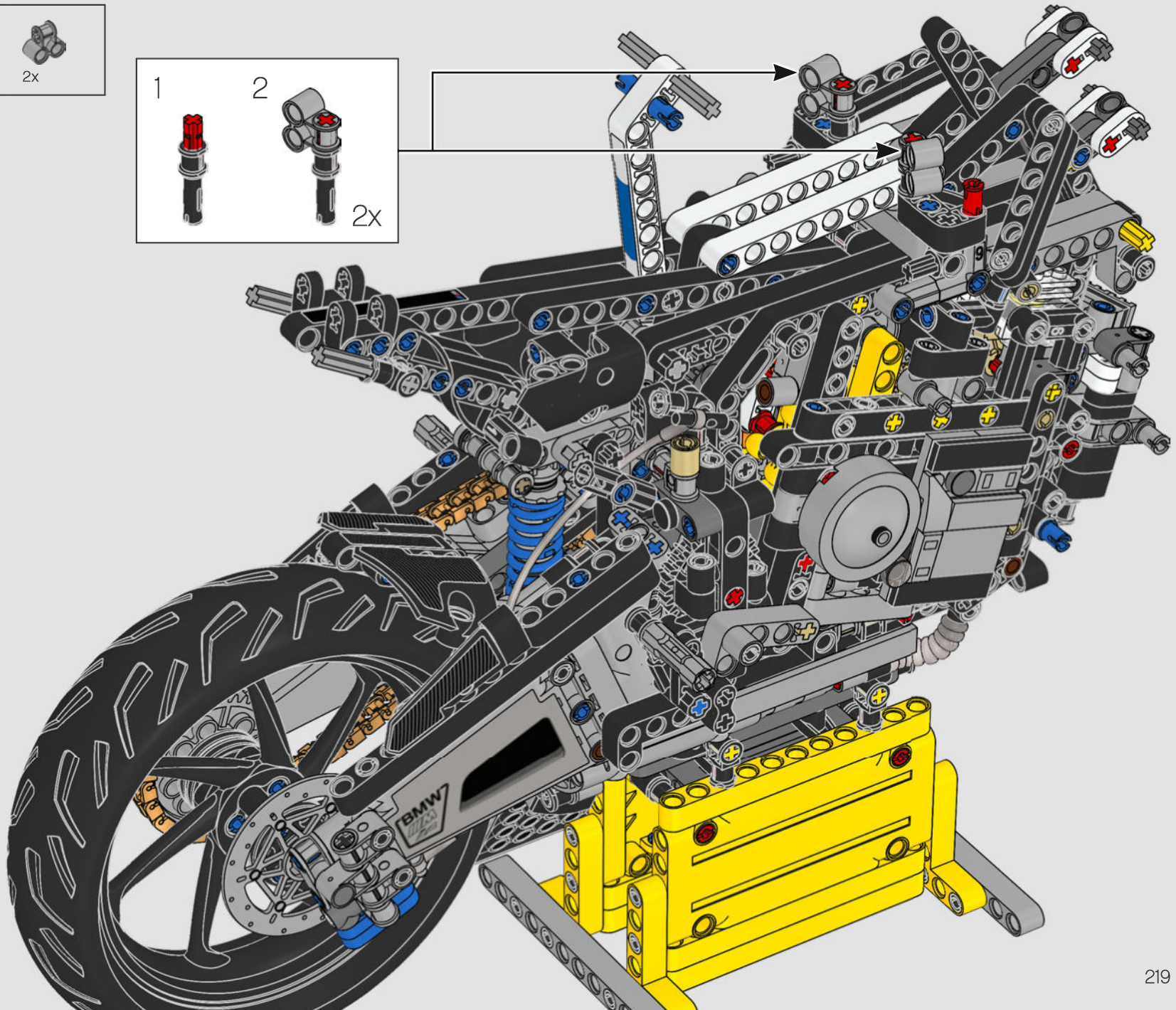
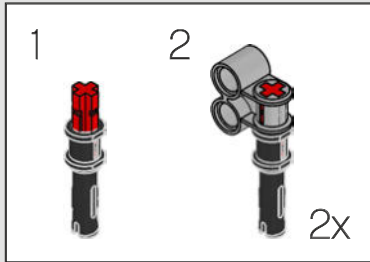

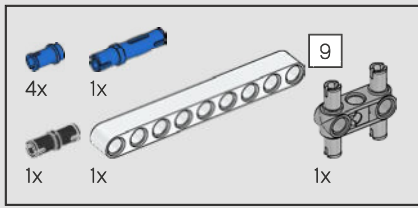

355

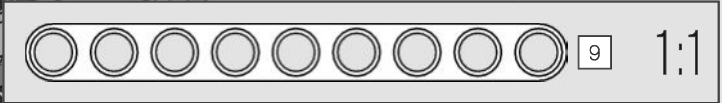
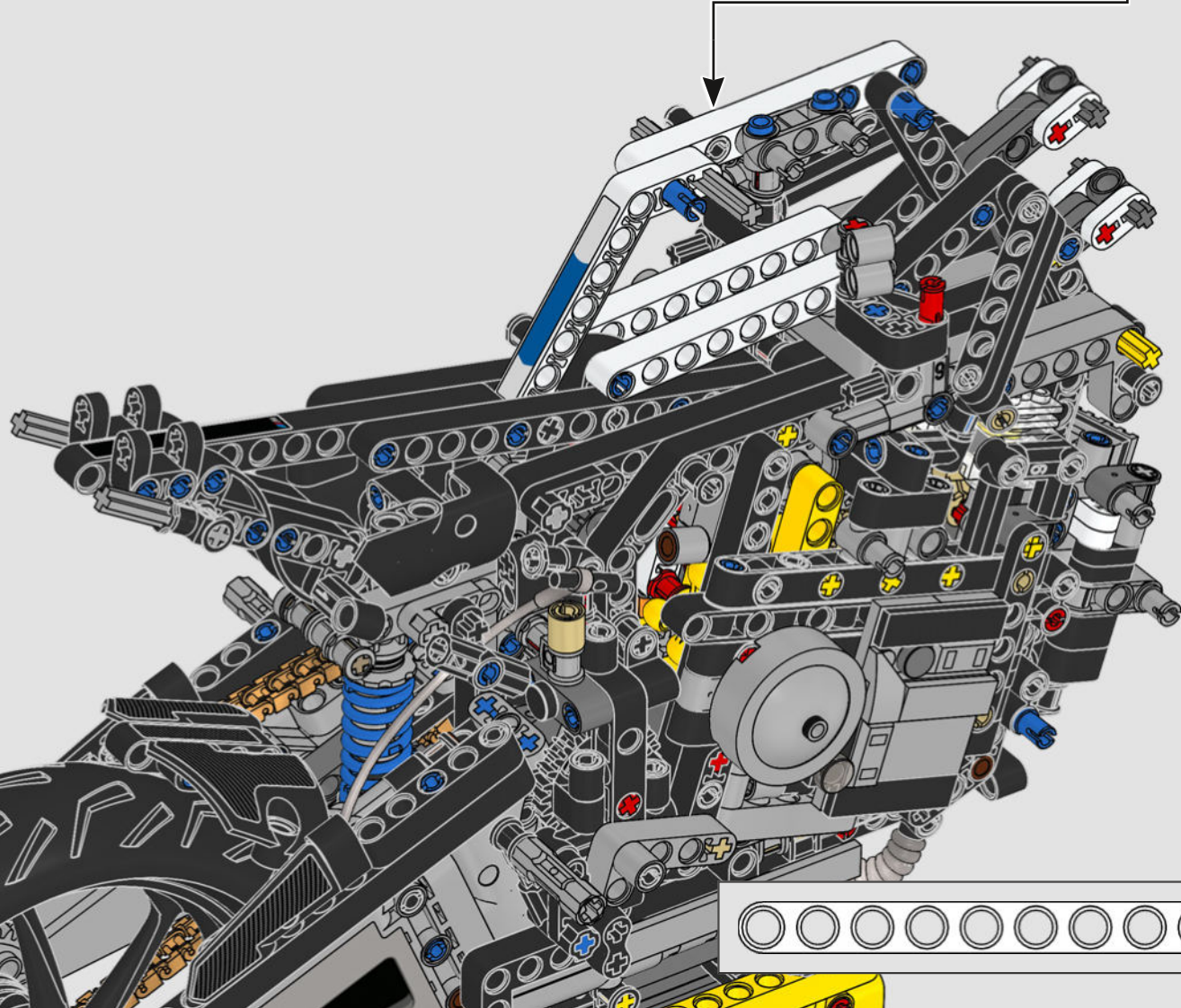
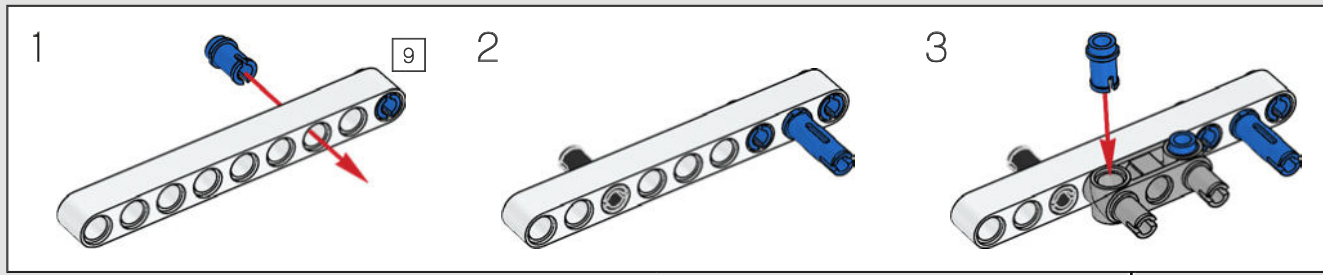

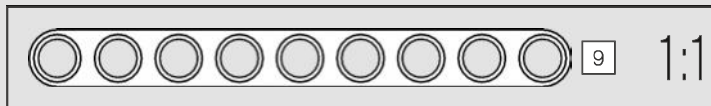
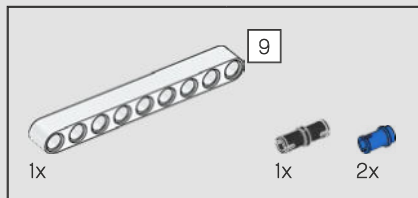

356

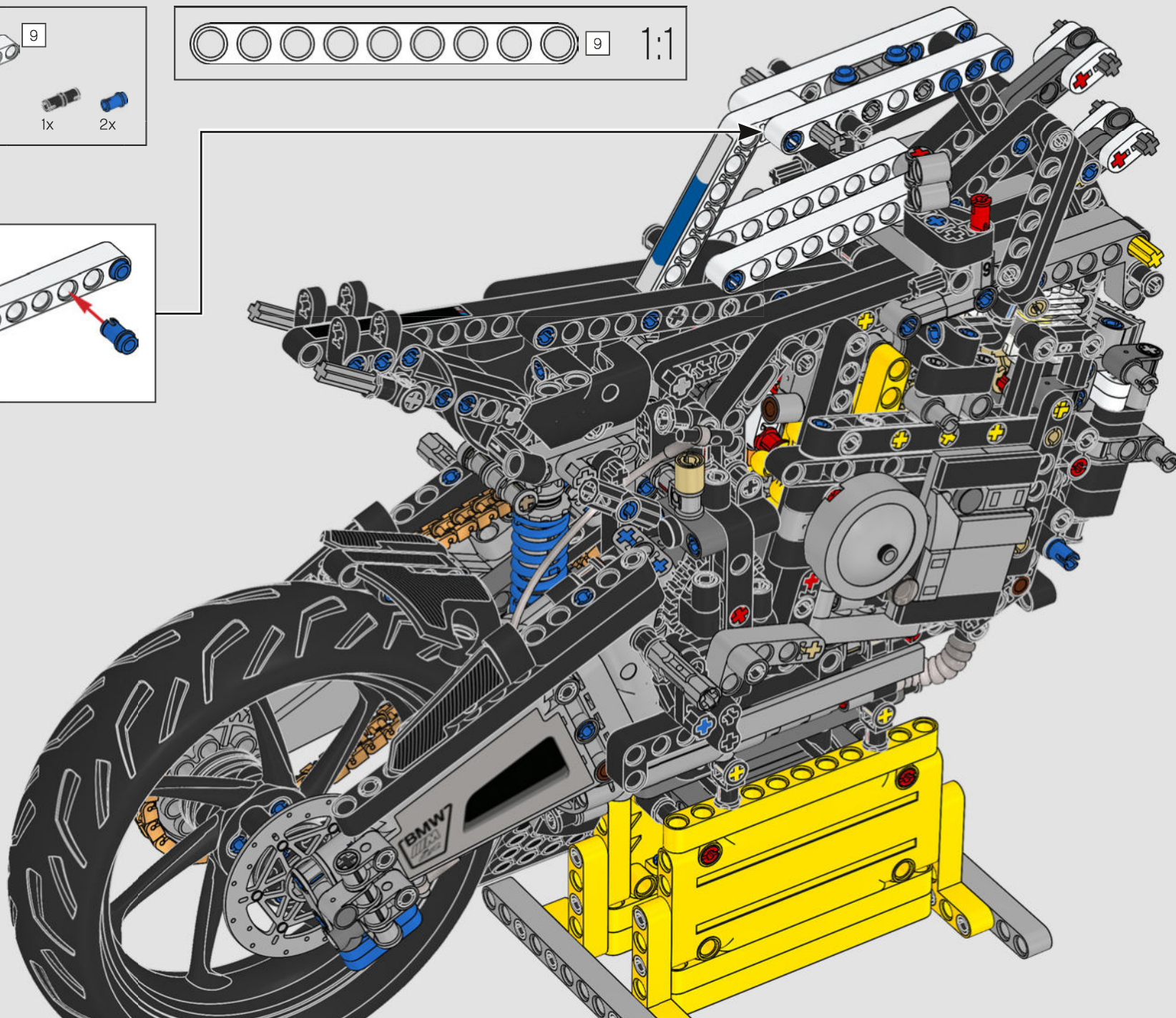
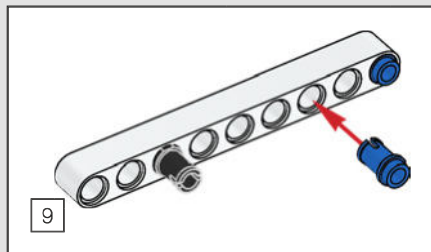

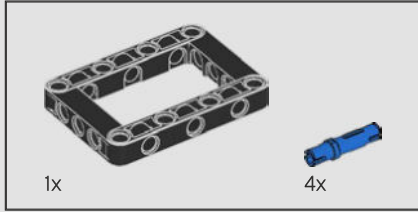
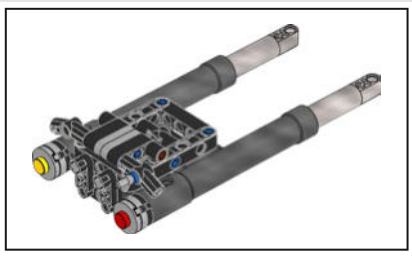

357

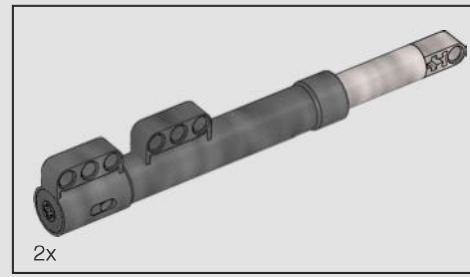
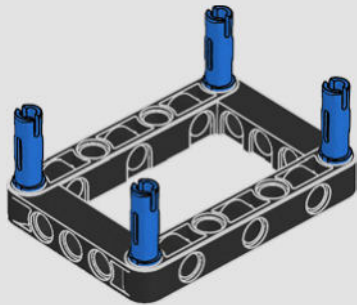

358

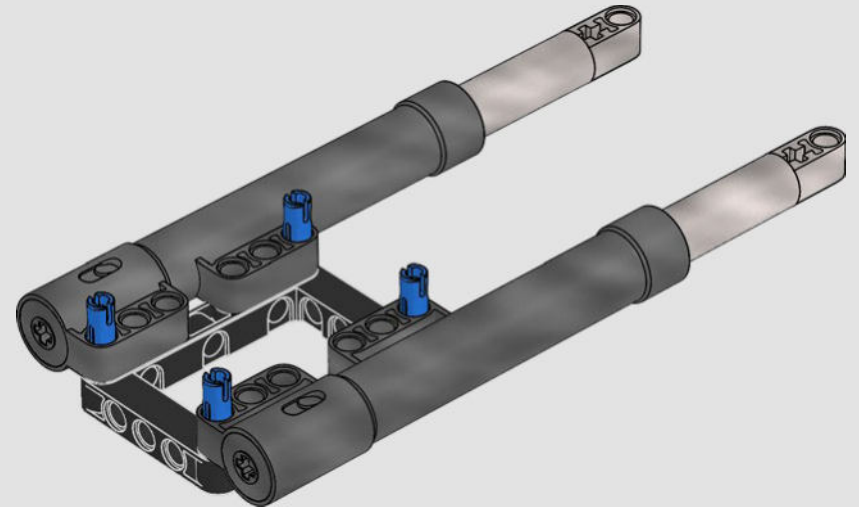

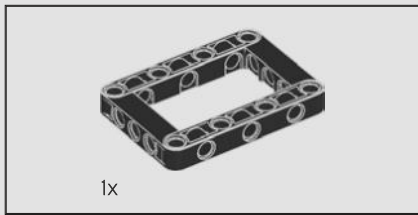

1x

359

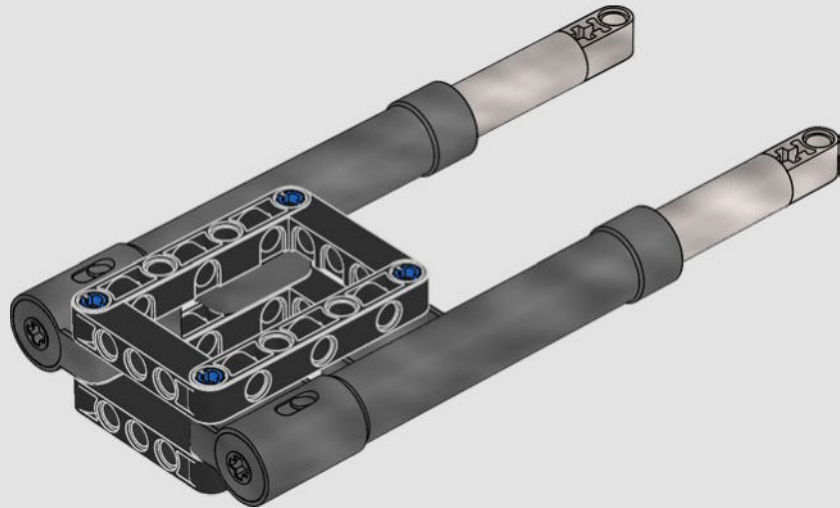

360

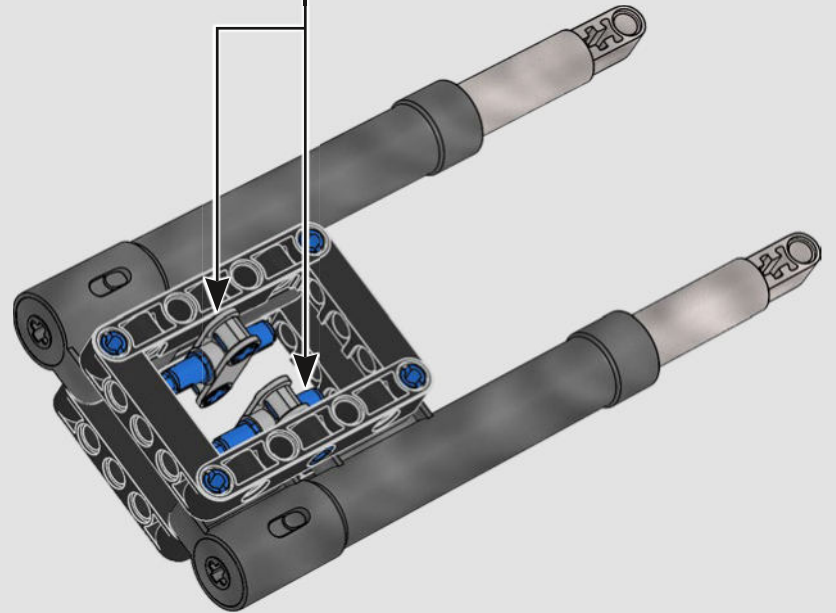
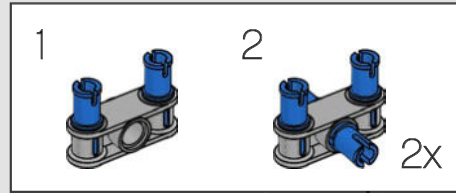
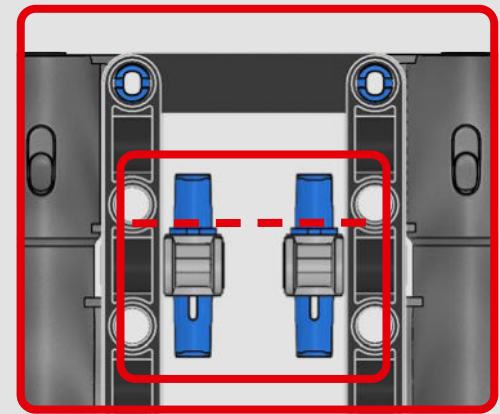

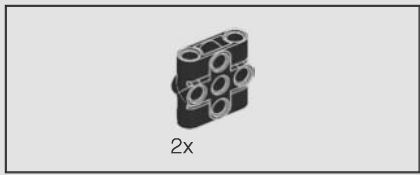

361

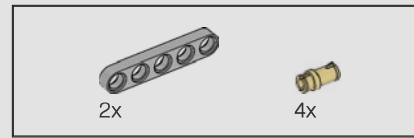
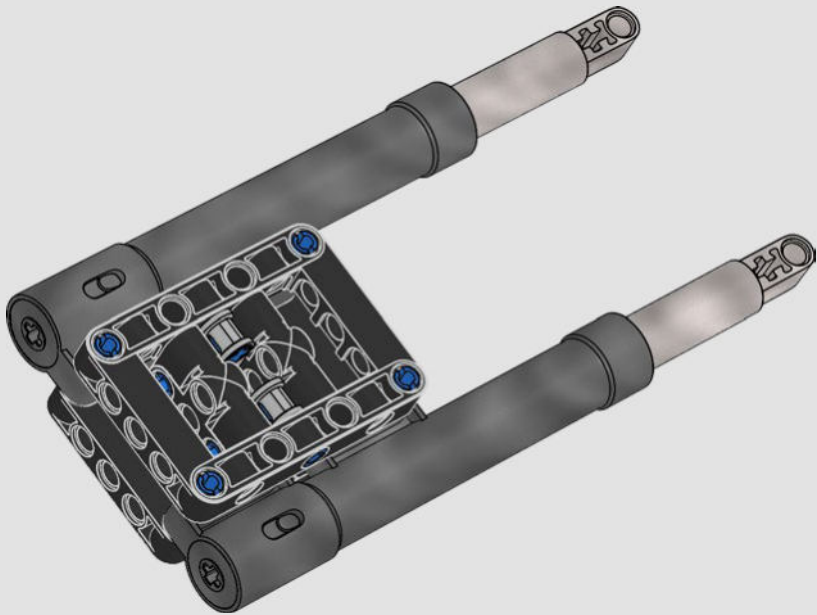

362

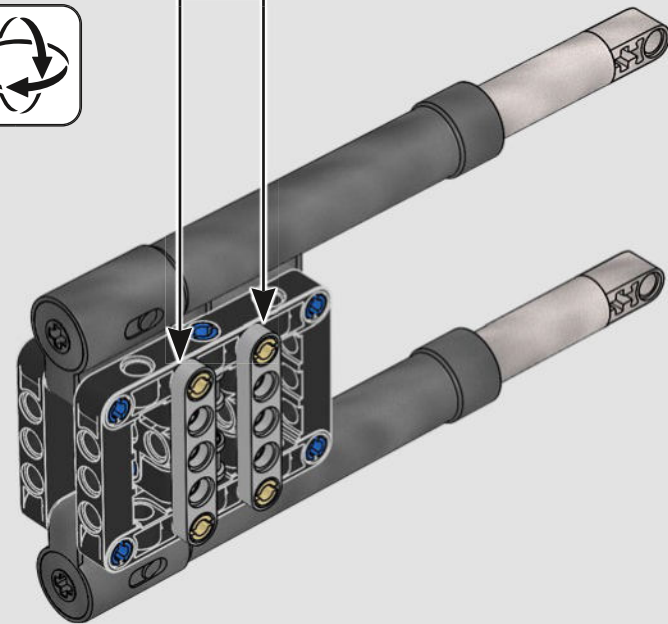
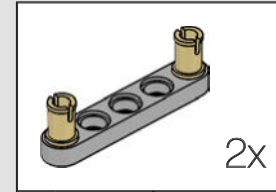

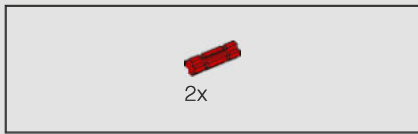

363

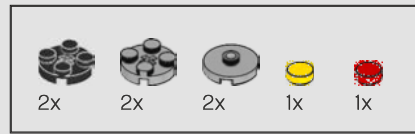
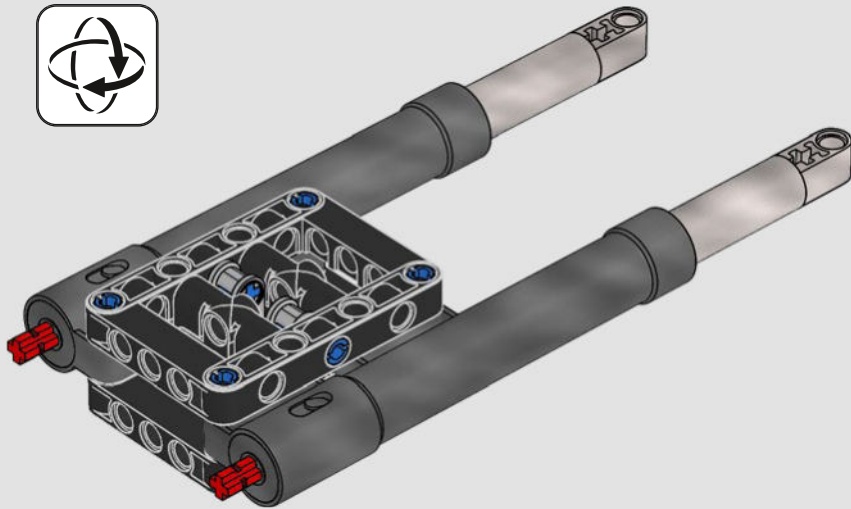

364

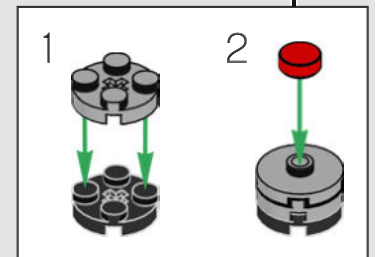
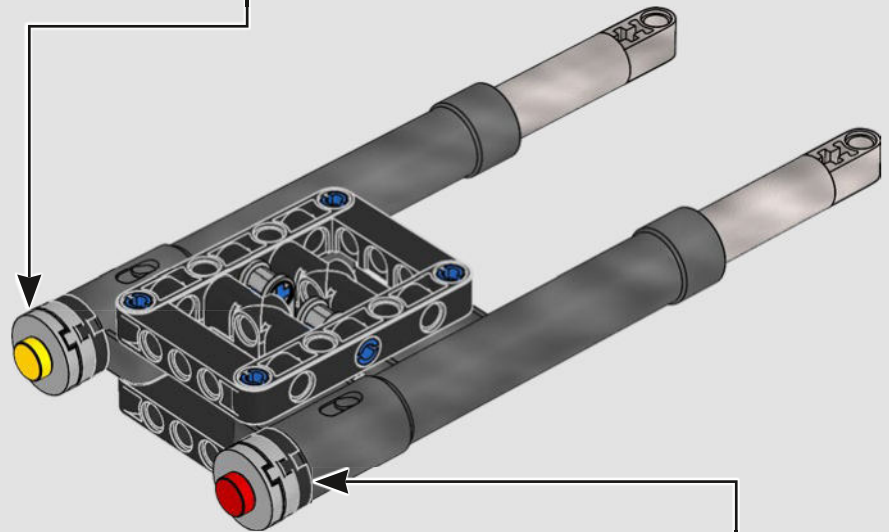
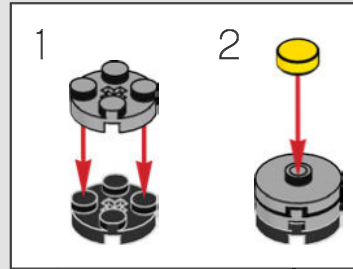



2x

365

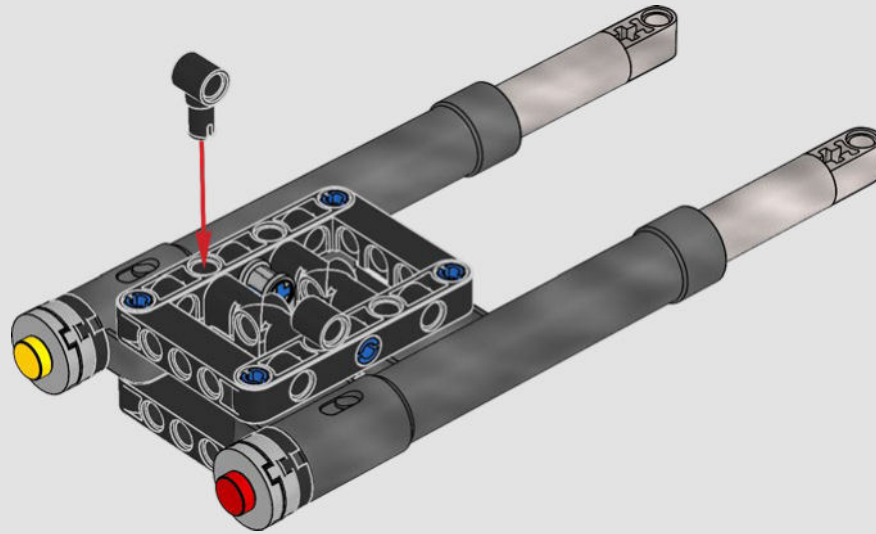

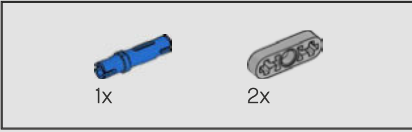
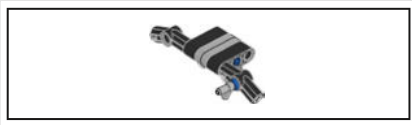

366

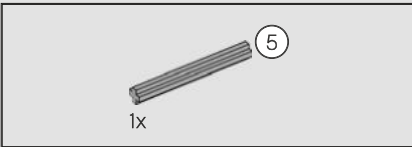
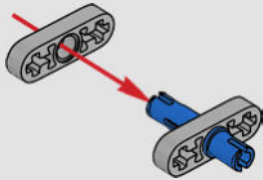

367

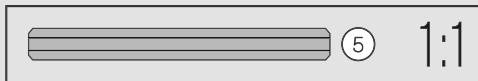
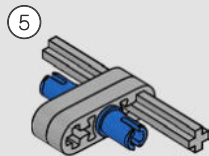

368

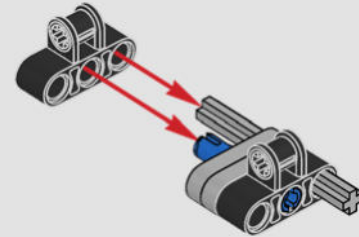

369

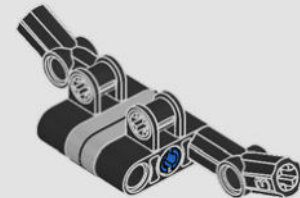

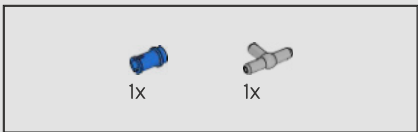

370

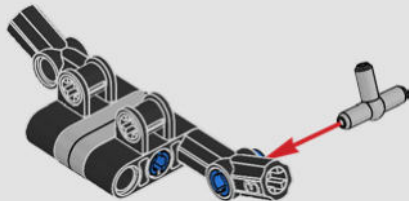

371

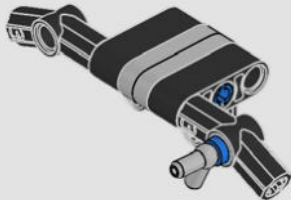

372

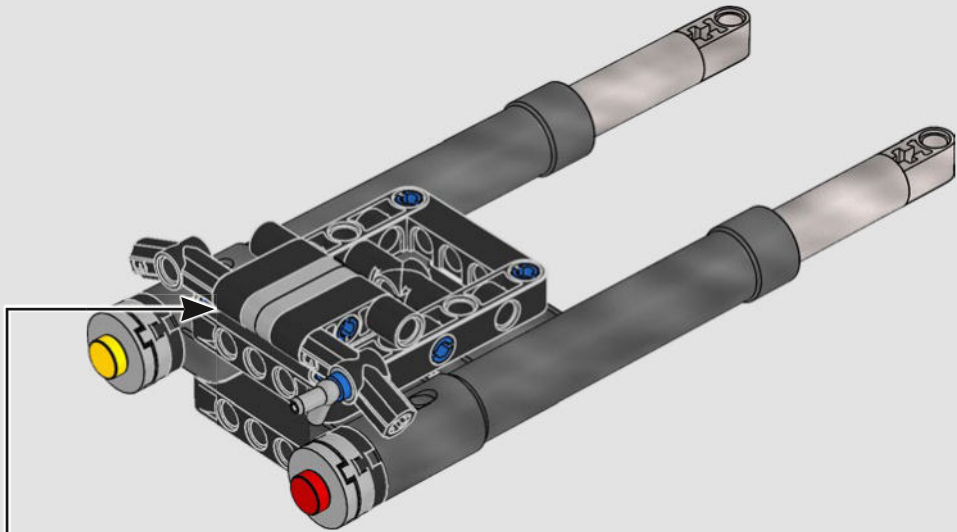

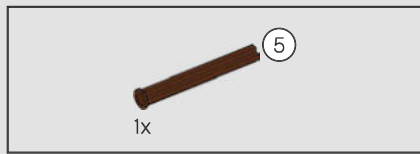

373

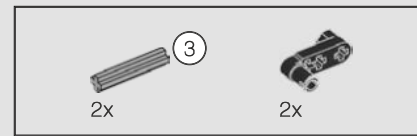
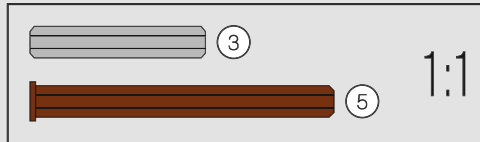
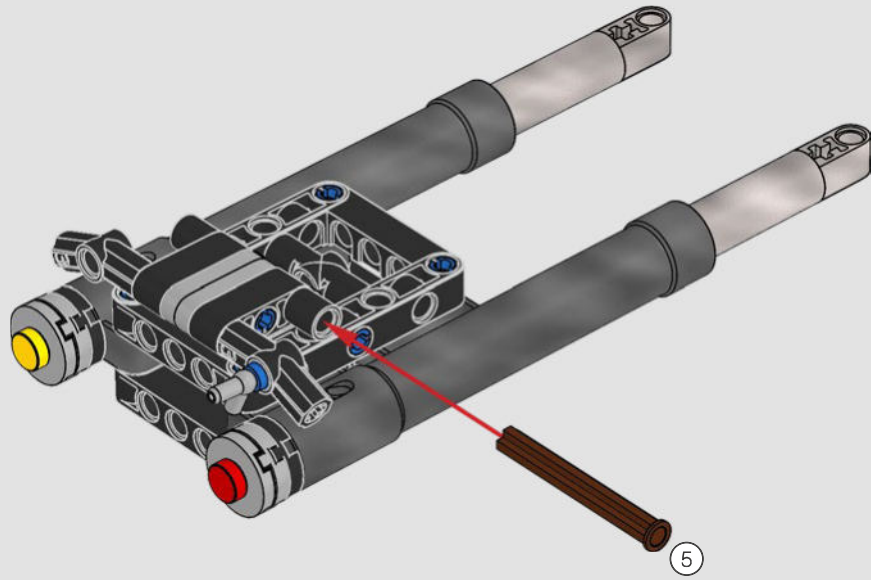

374

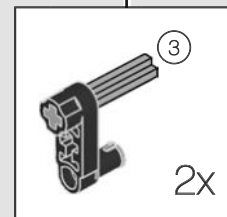
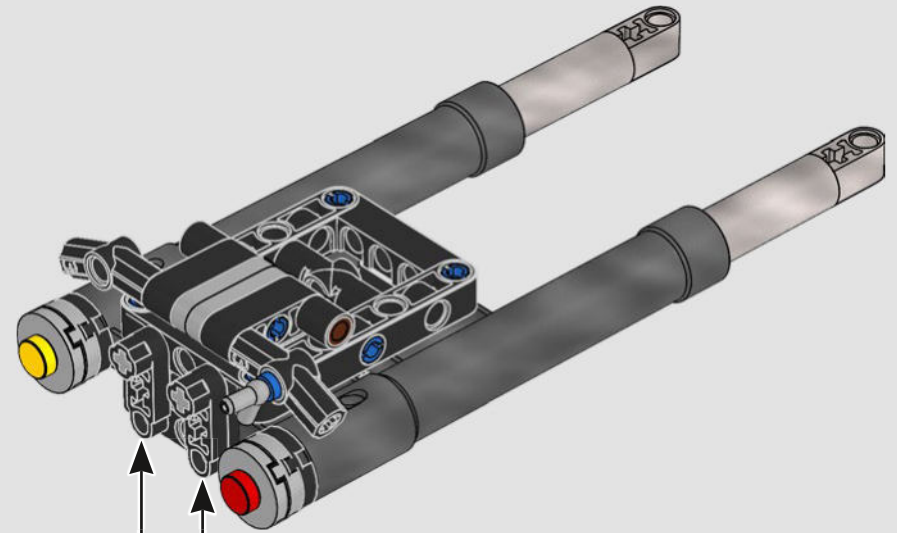

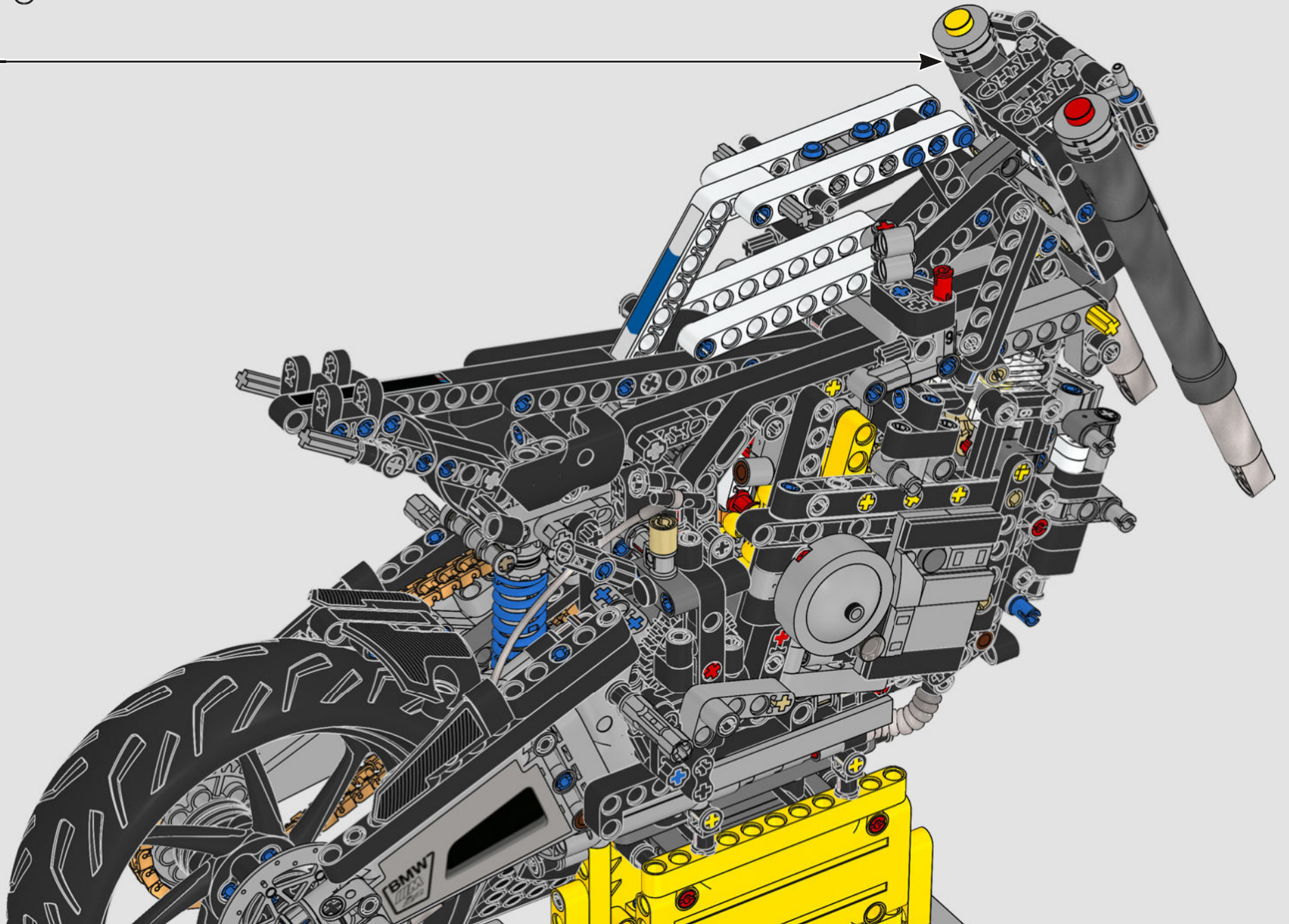

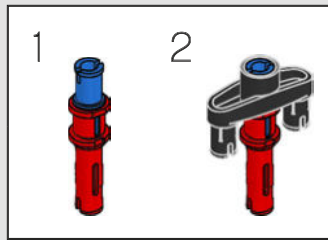
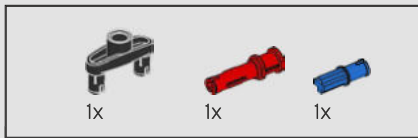

376

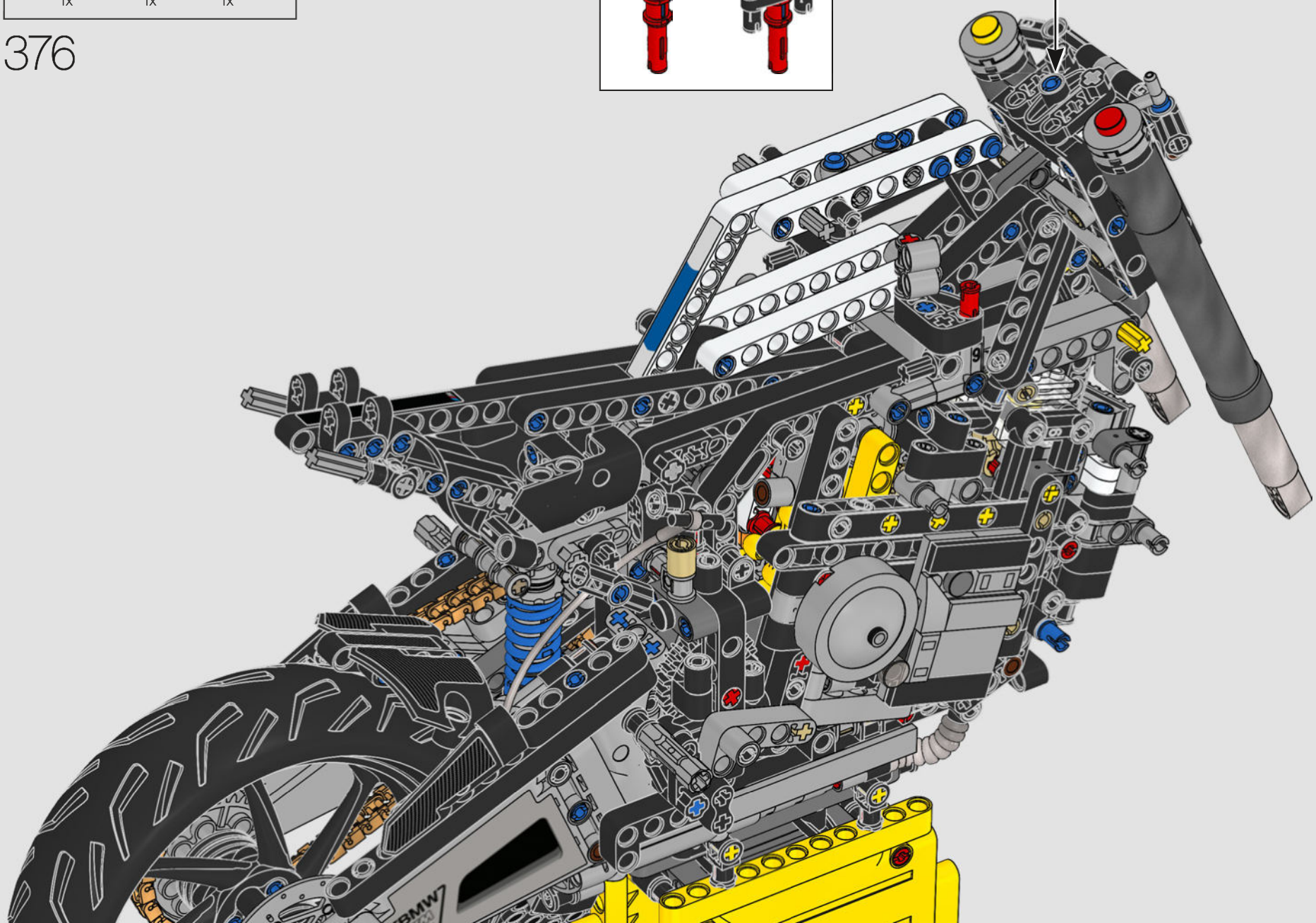

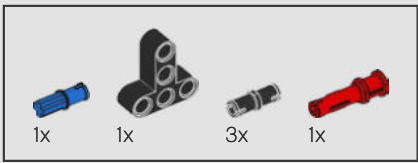

377

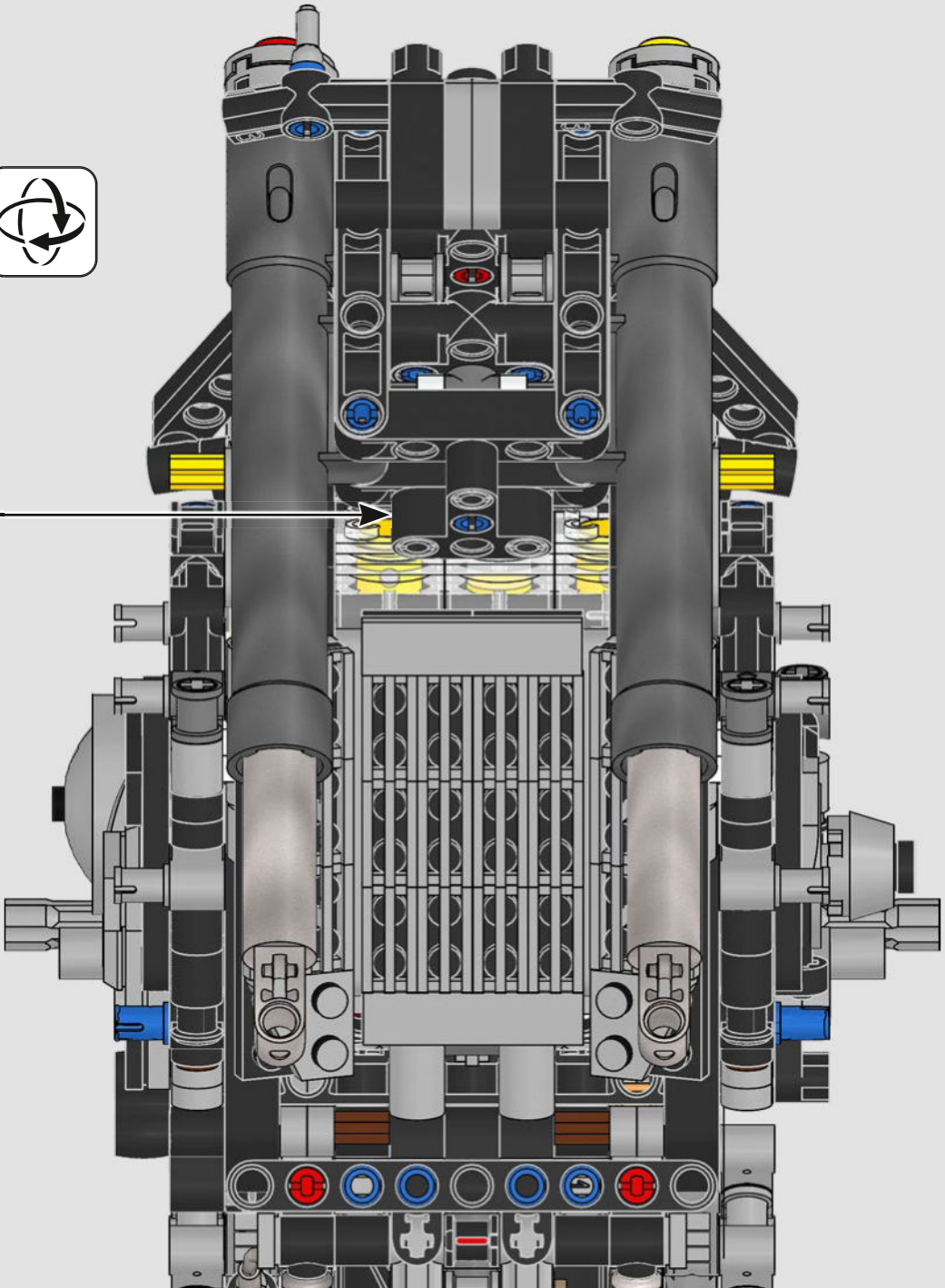
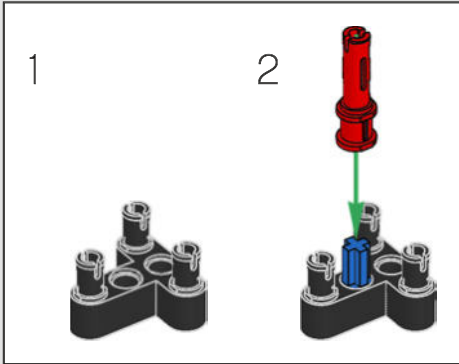

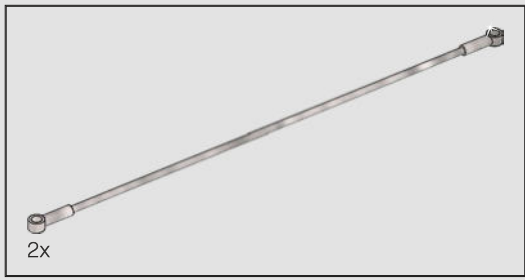

378

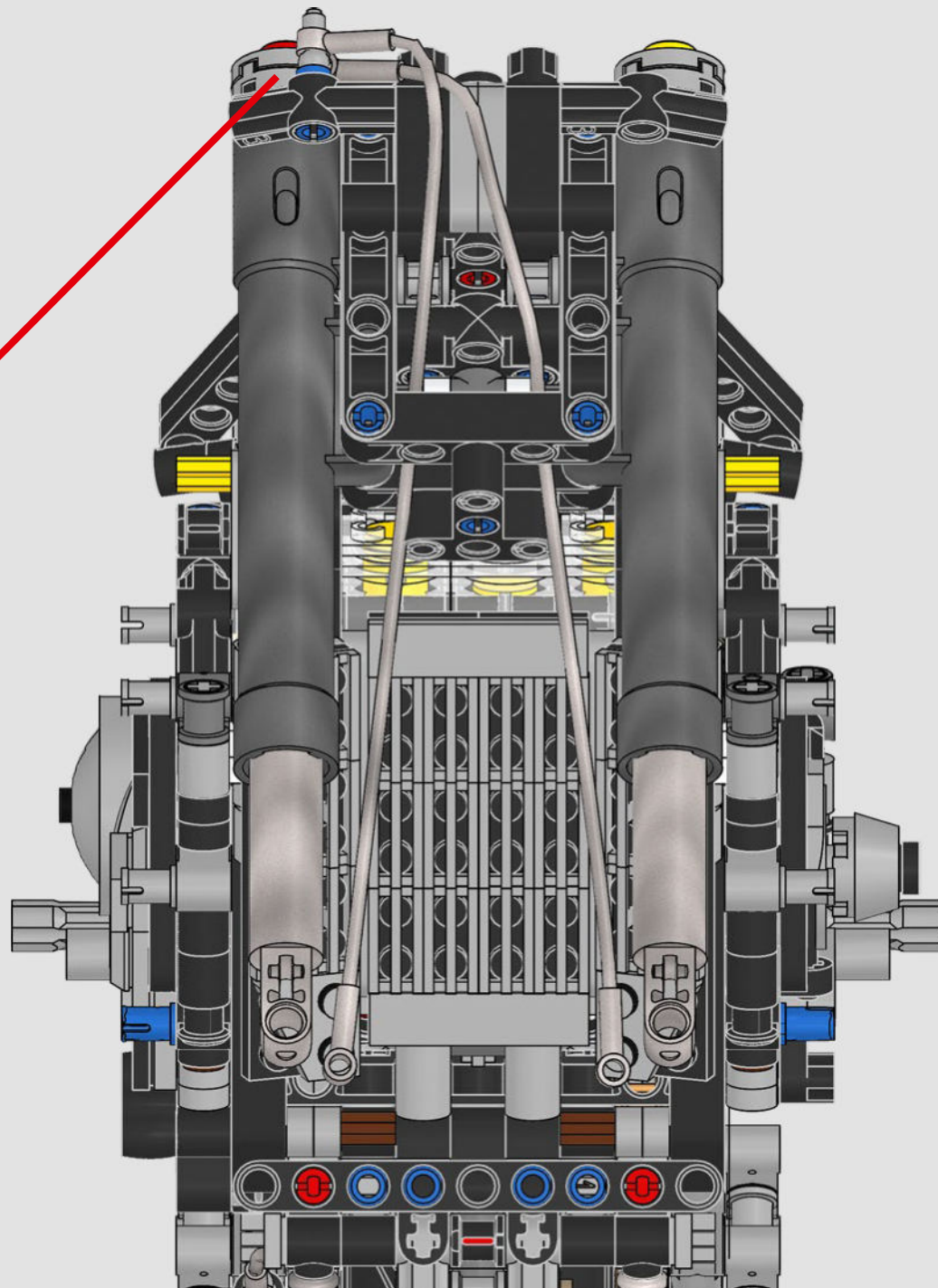
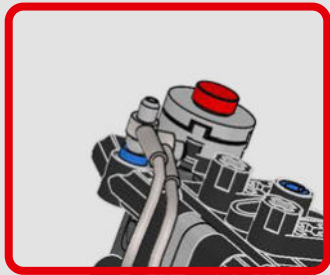

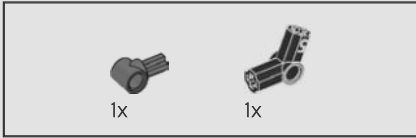
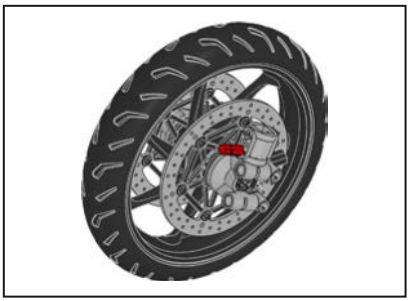

379

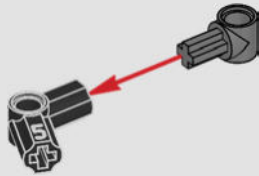

380



381

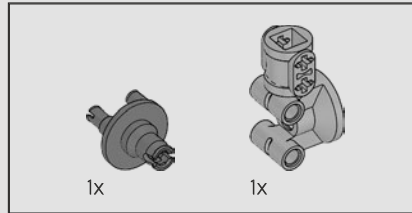
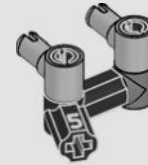

382

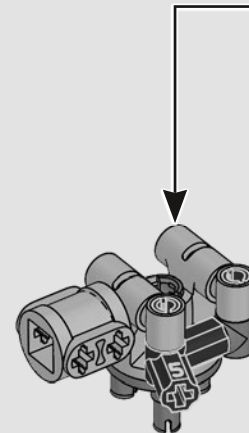
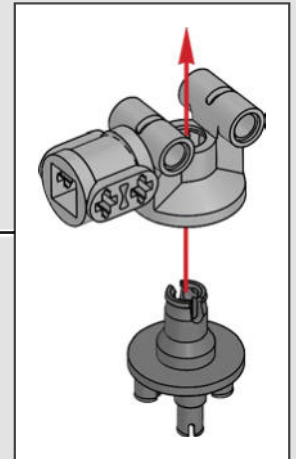

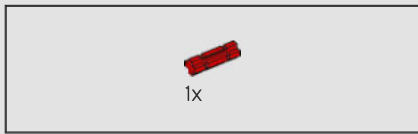

383

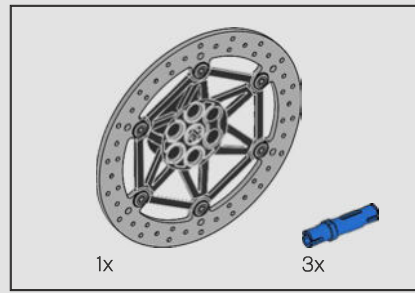
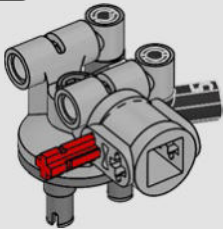

384

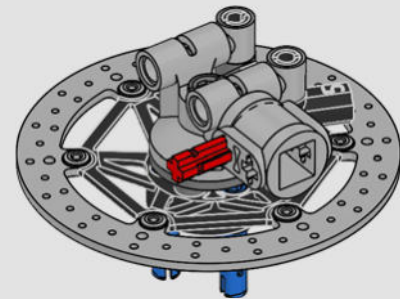
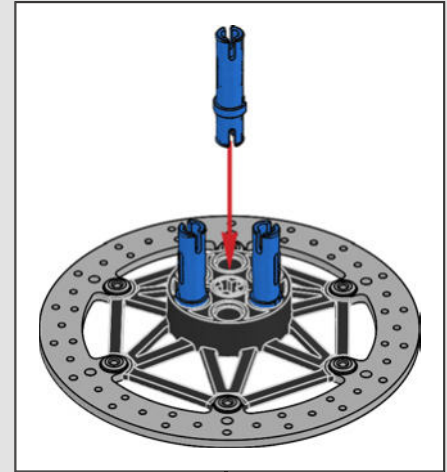

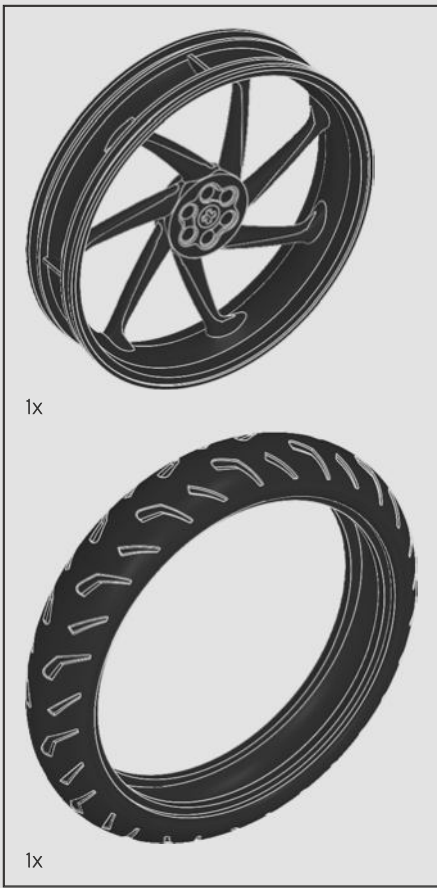

1x

1x

385

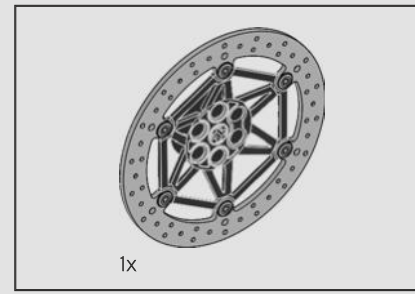
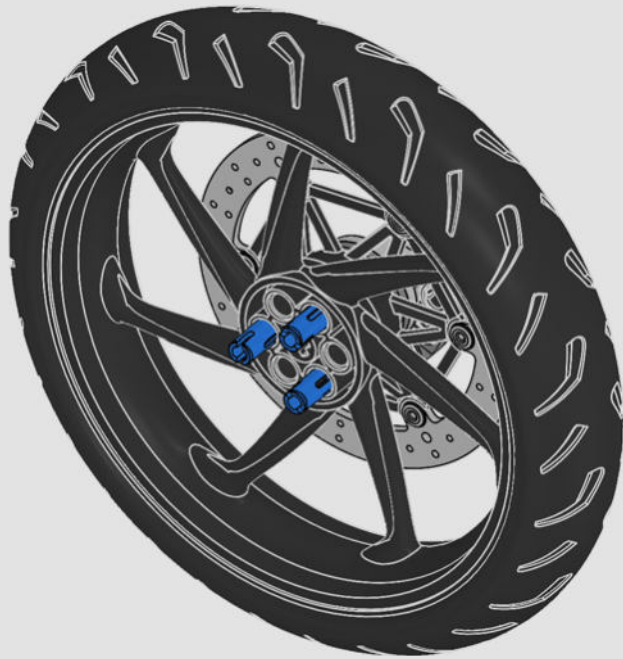

1x

386



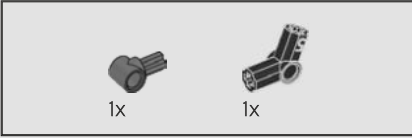
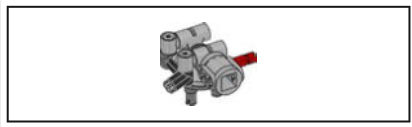

387

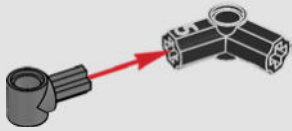

388



389

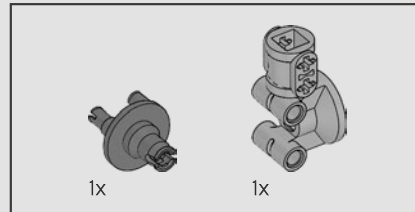
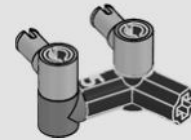

390

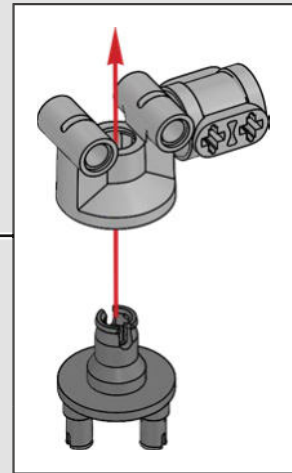
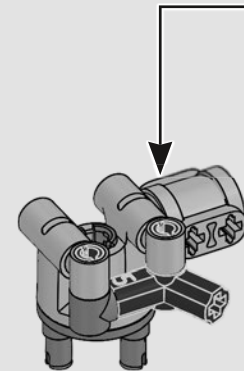



1x

391

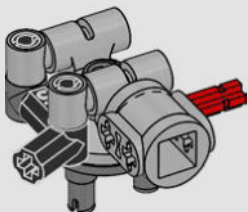

392

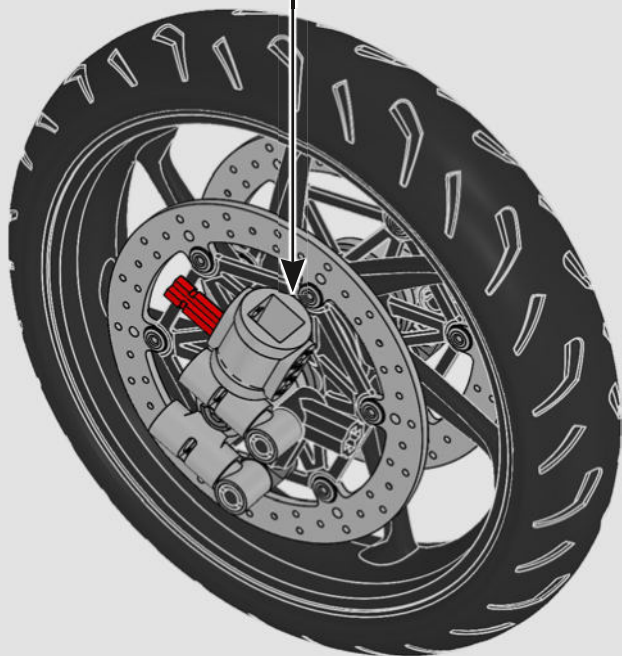

393

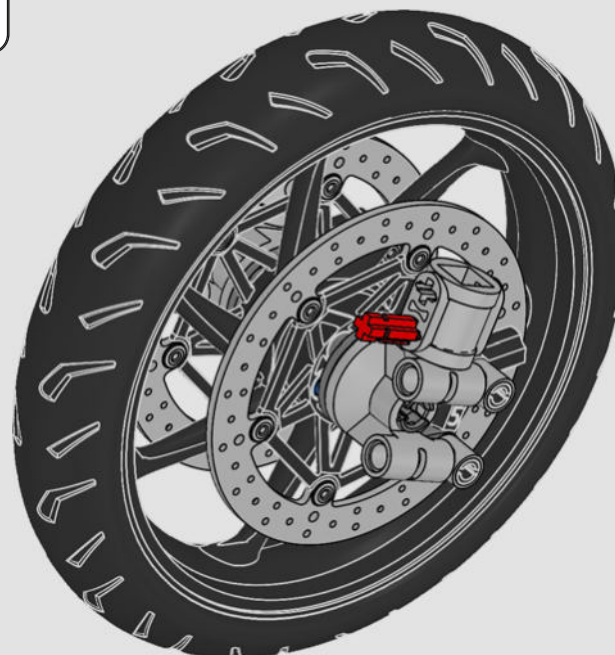

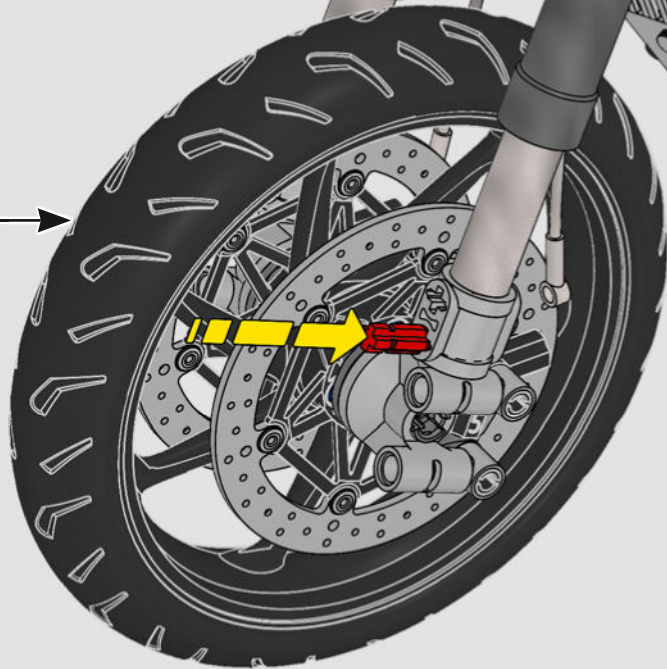
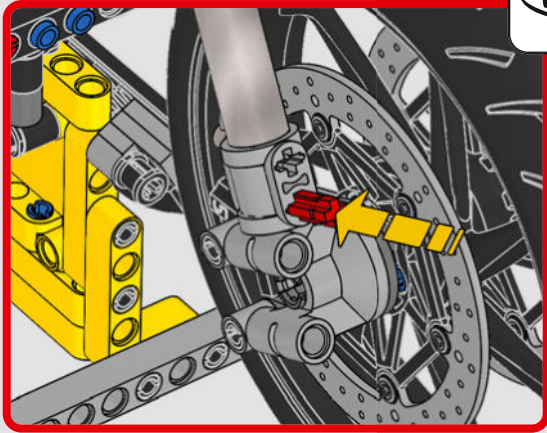

BMW MOTORRAD M 1000 RR

Power	212 HP
Nmax	15,100 rpm
Torque	113 Nm
CC	999
Ymax	306 km/h
Acceleration	325 km/h (Track Transmission)
	0-100 km/h < 3.1 sec.
	0-200 km/h < 7.3 sec.
Weight, Din	192 kg
Downforce	Winglet 16.3 kg

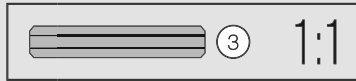
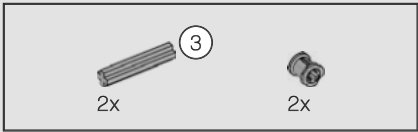

395

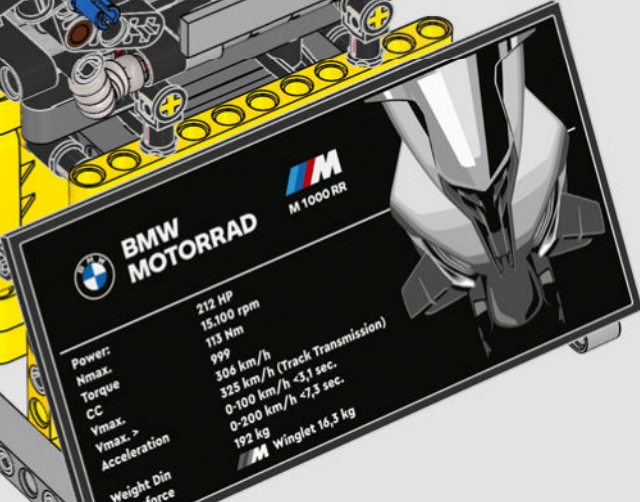
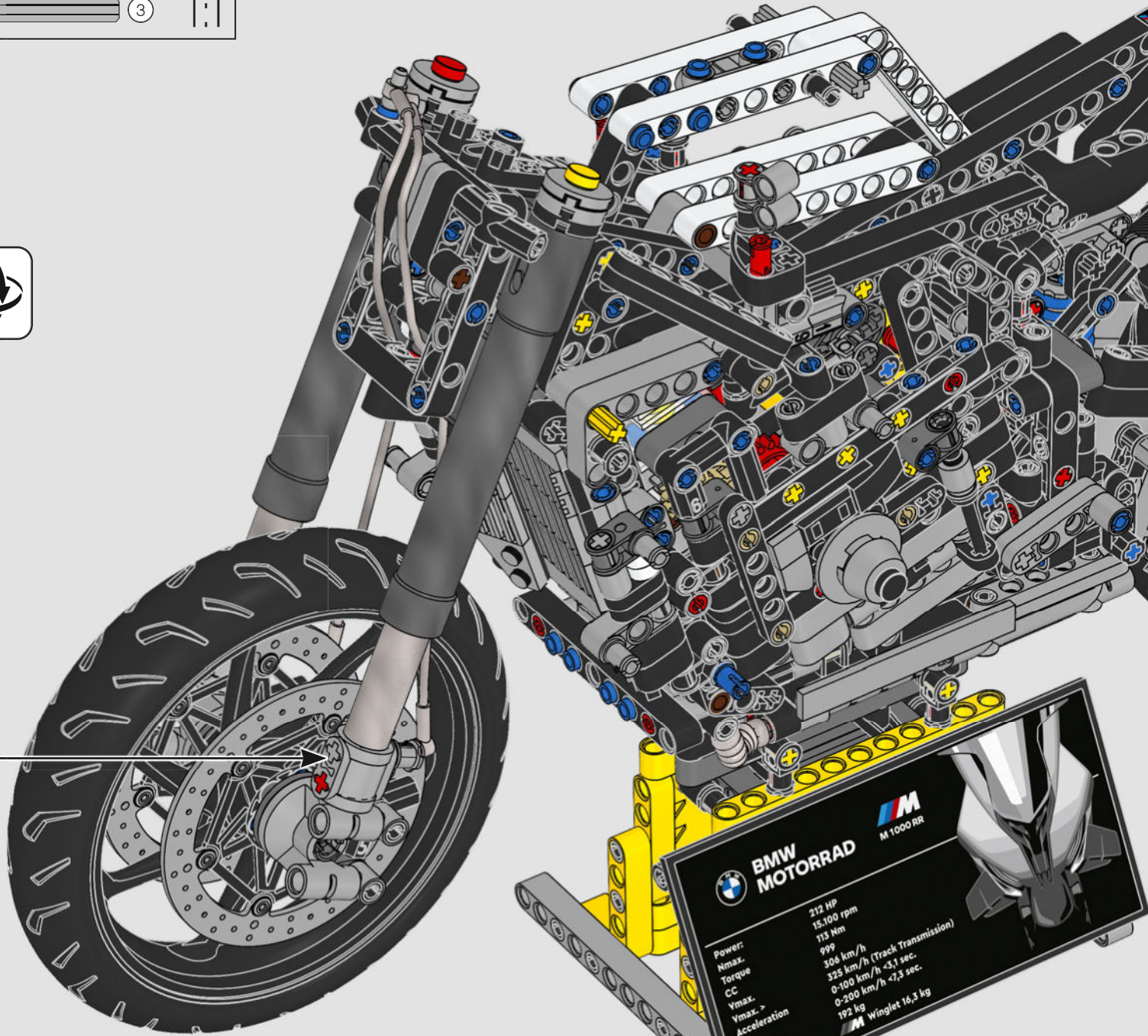
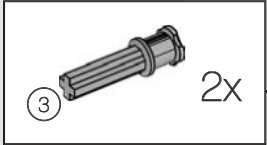
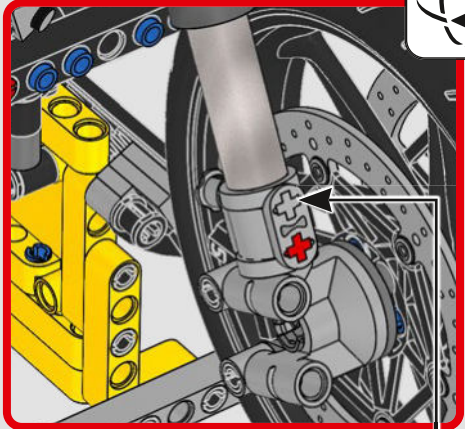



396



397

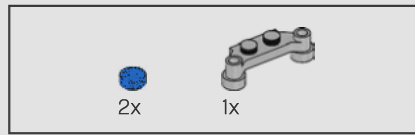

398

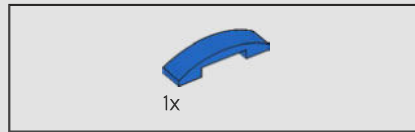
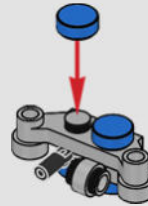

399

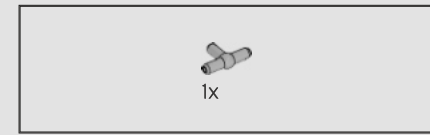
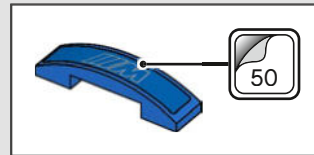

400

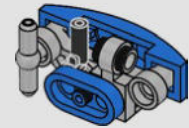
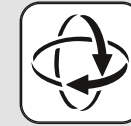

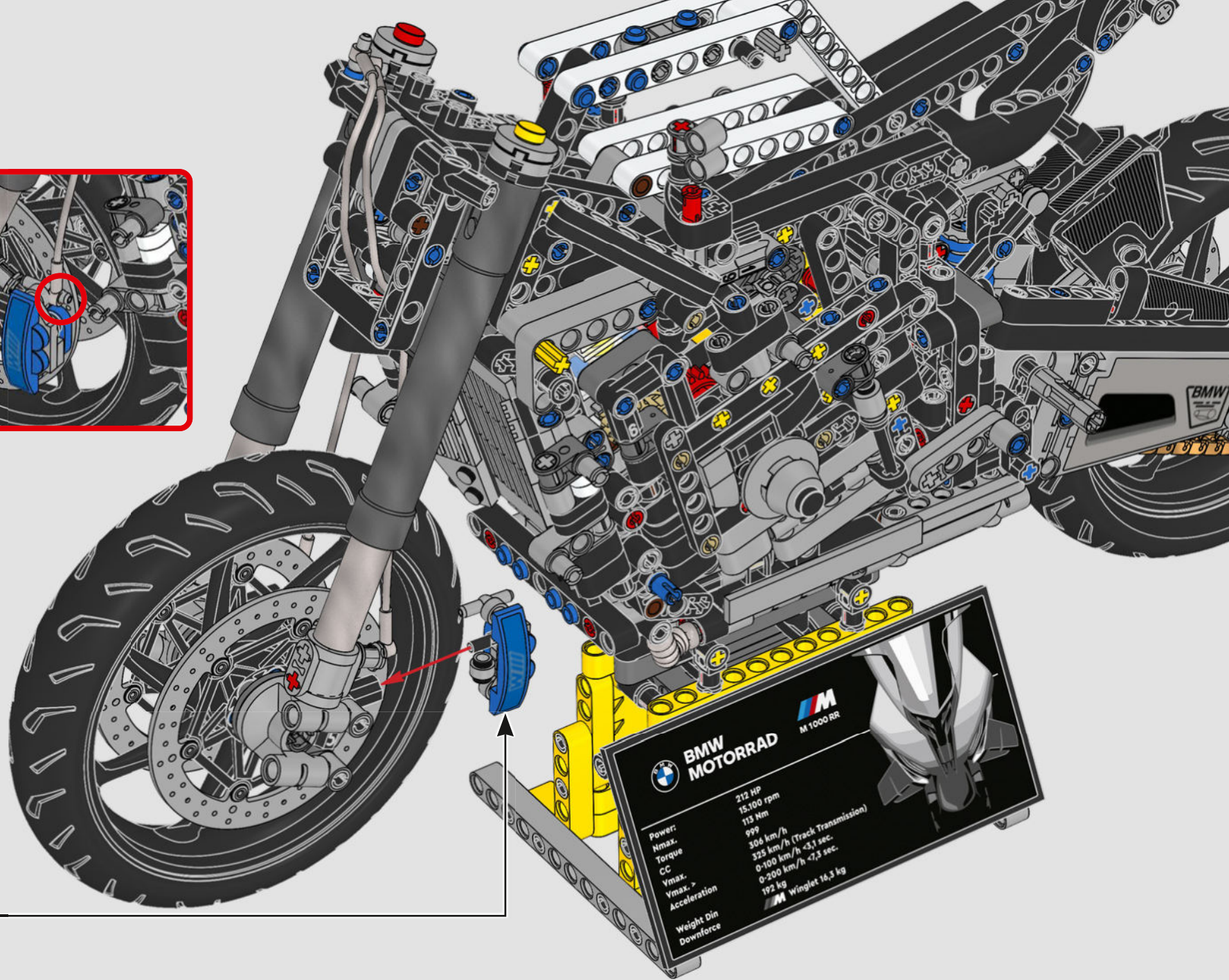
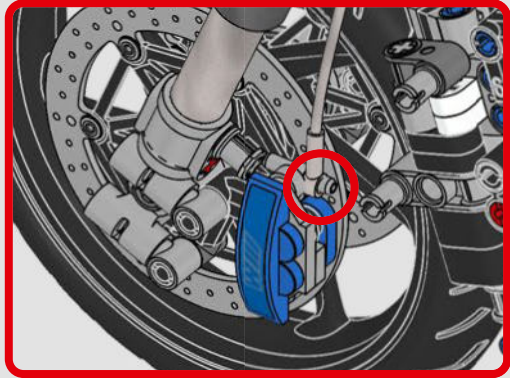



402



403

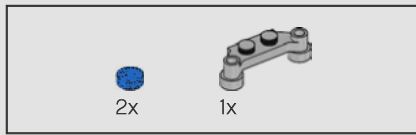

404

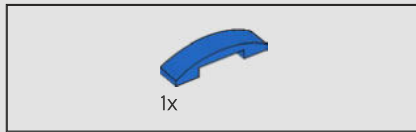
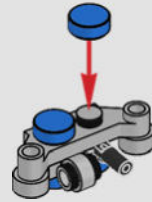

405

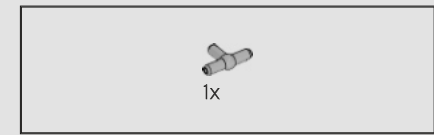
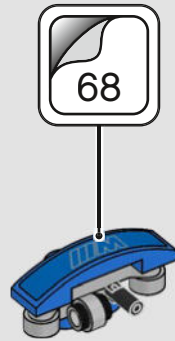

406

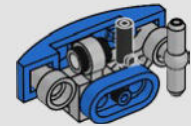

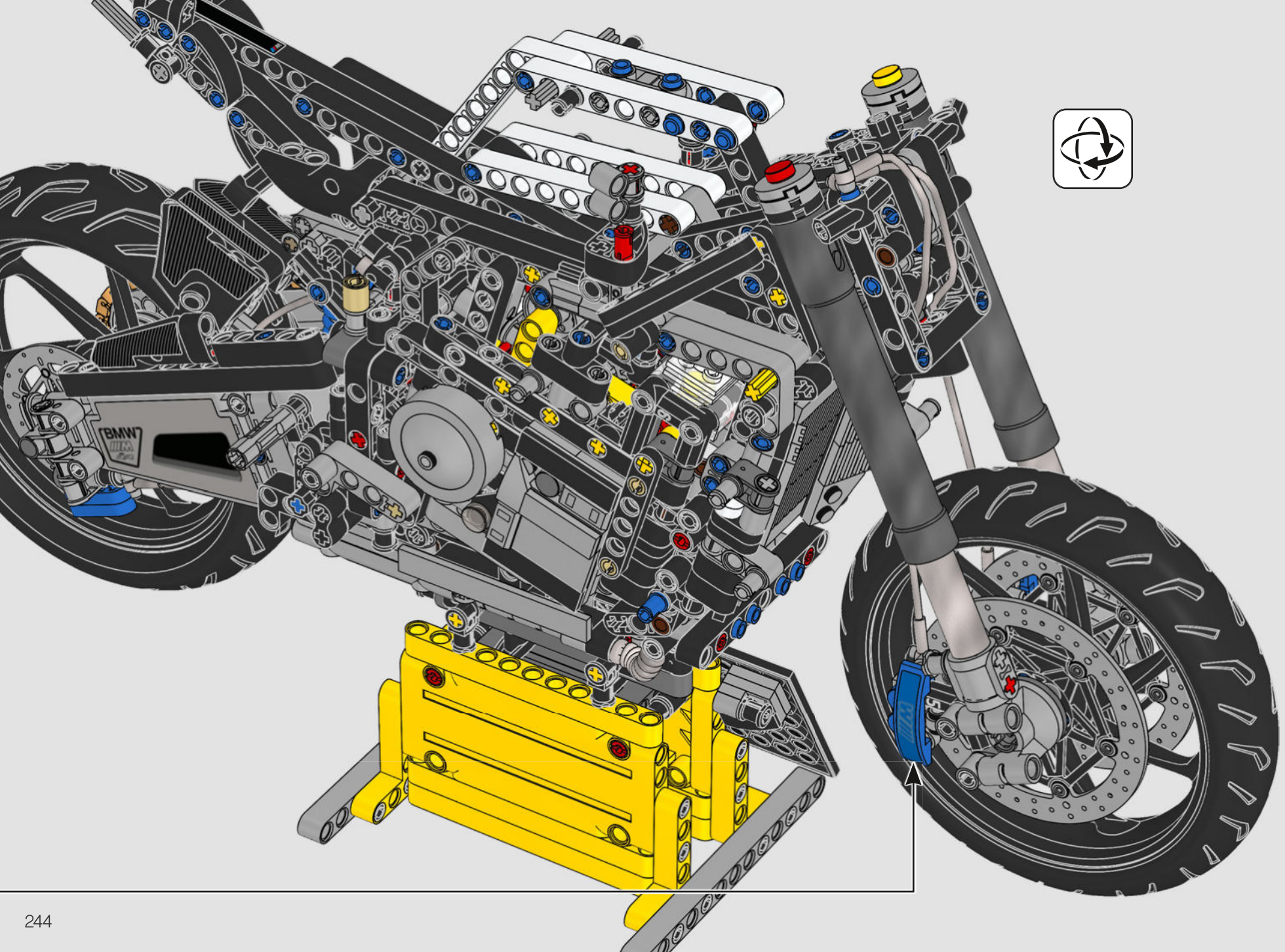

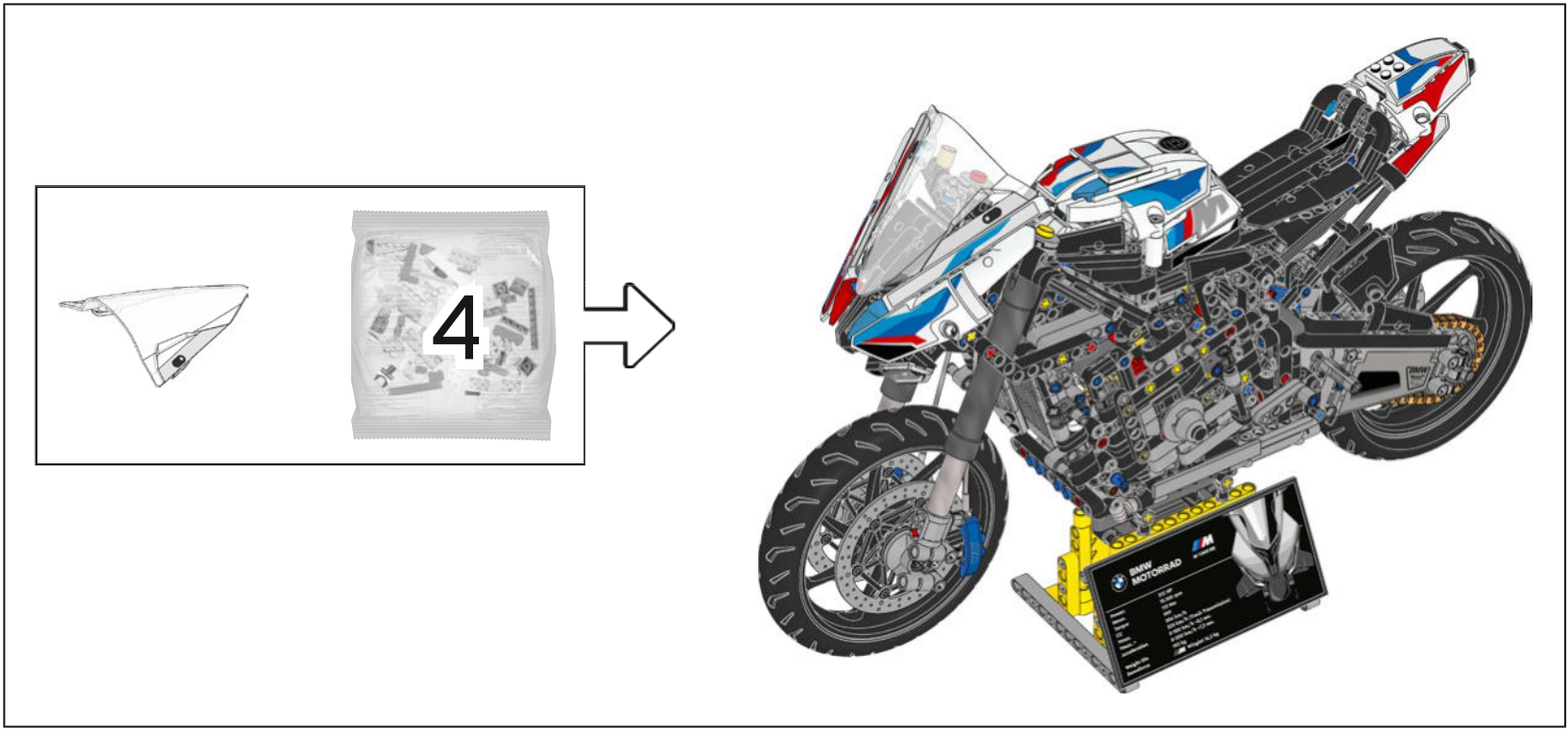

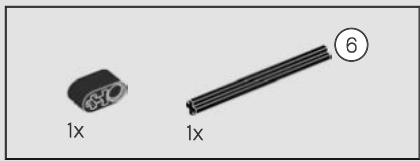

407

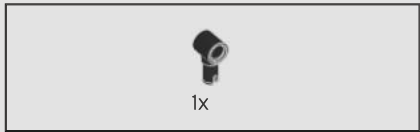
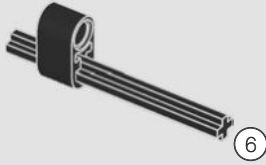

408

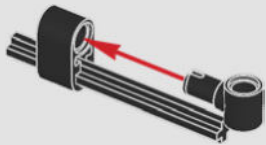

409

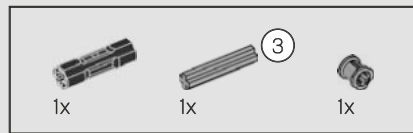
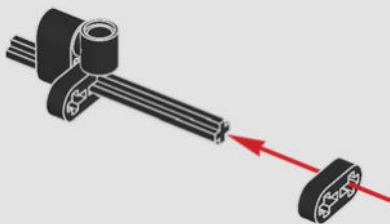

410

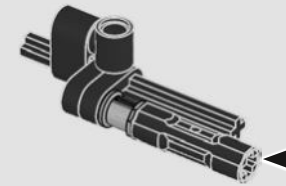
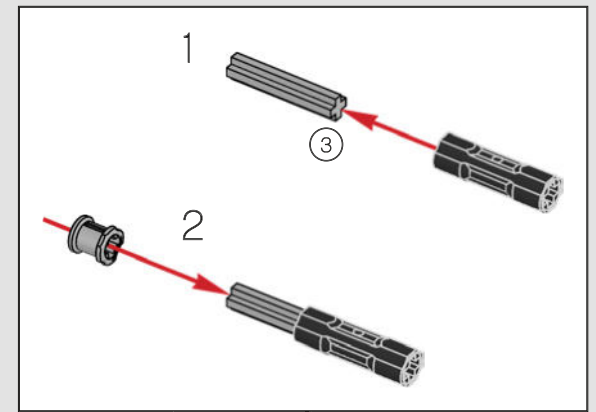

411

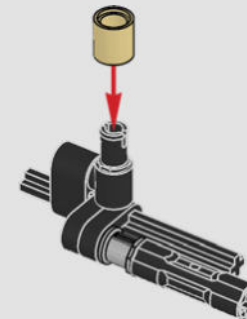

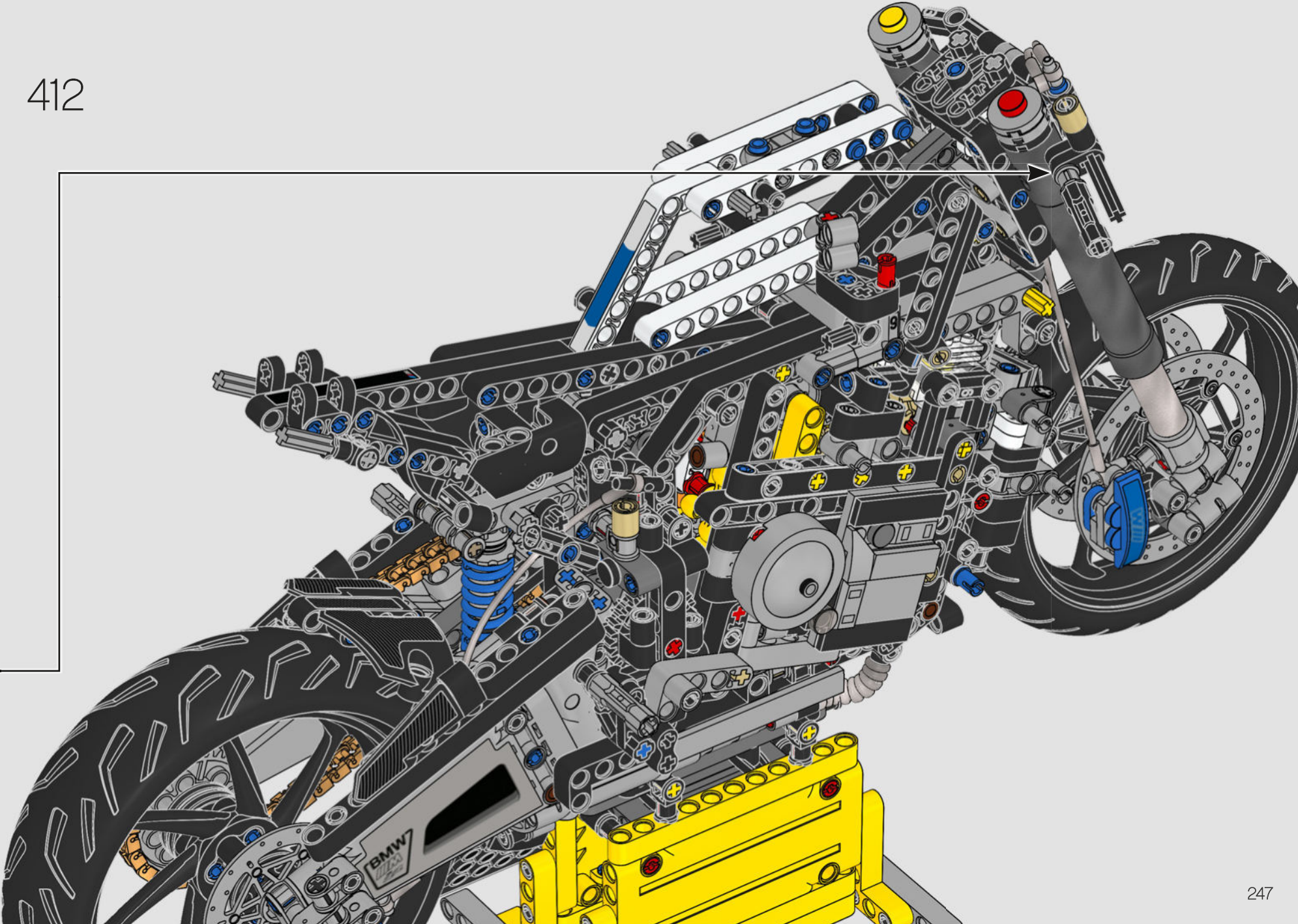



413

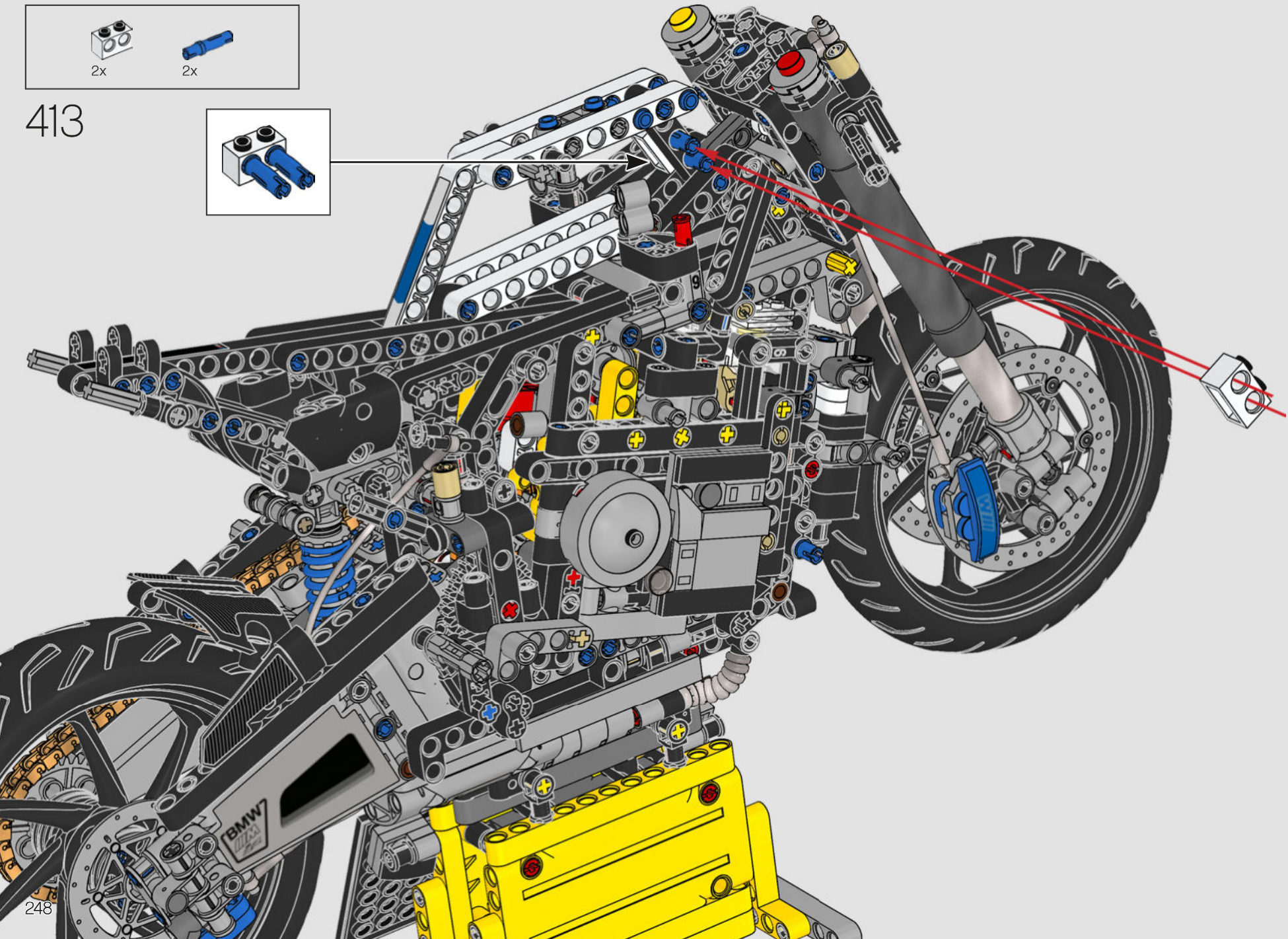
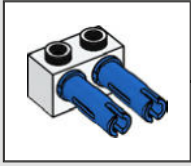

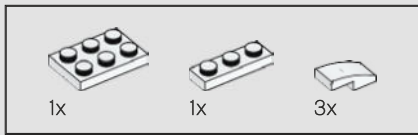

414

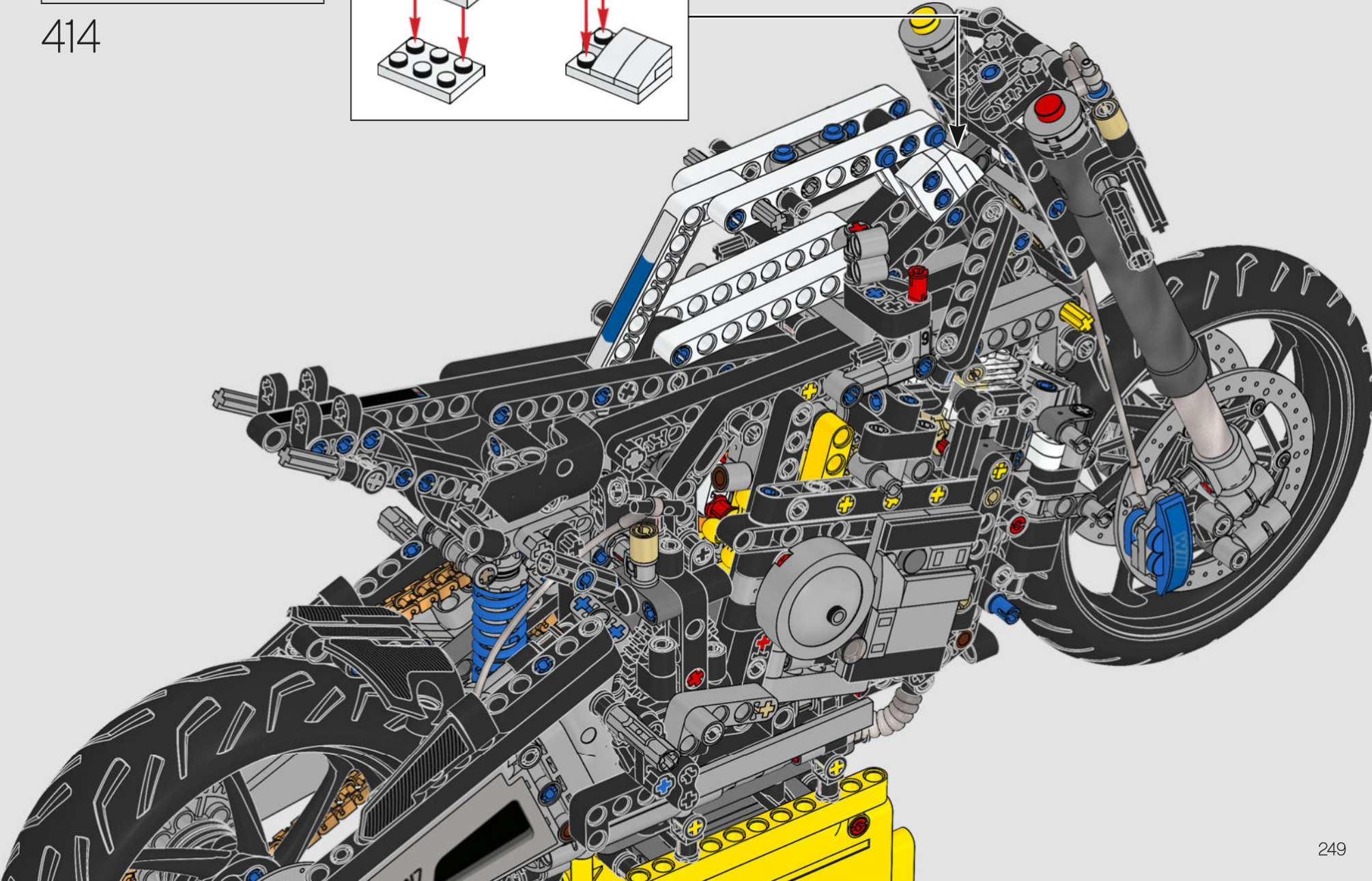
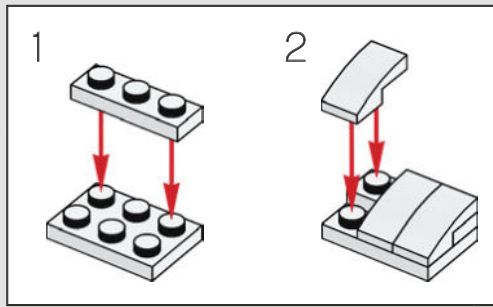

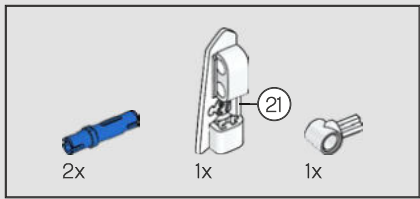

415

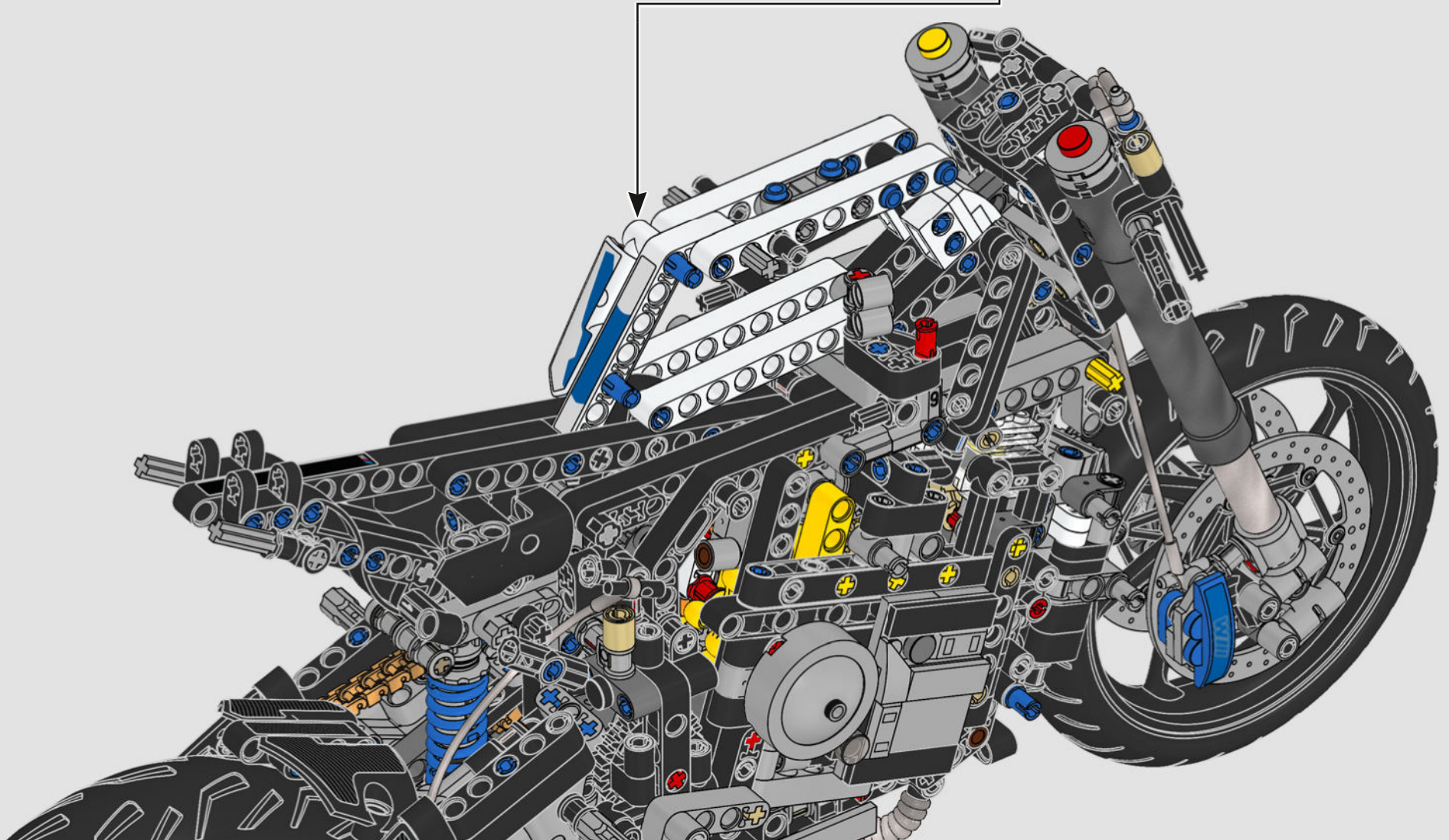
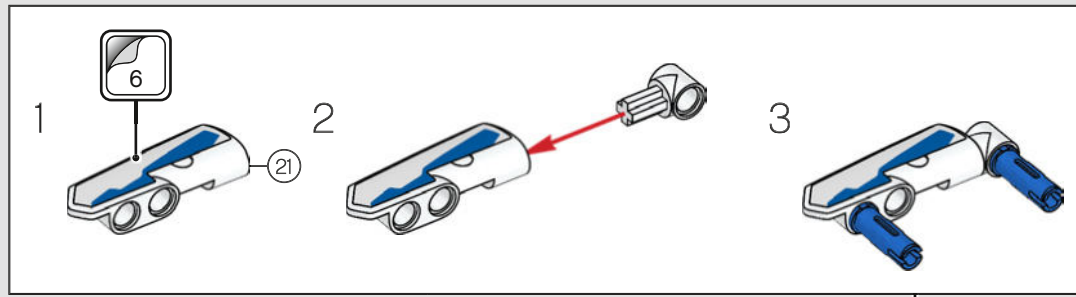

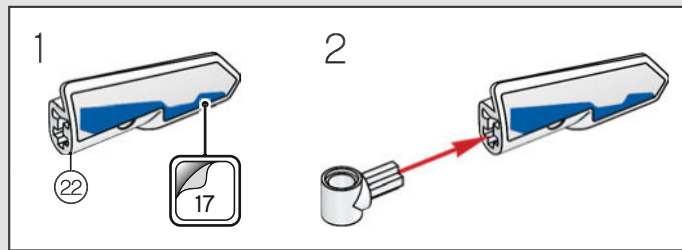
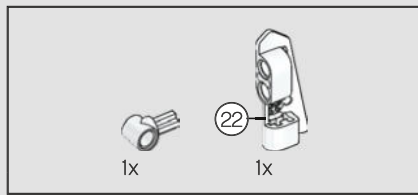

416

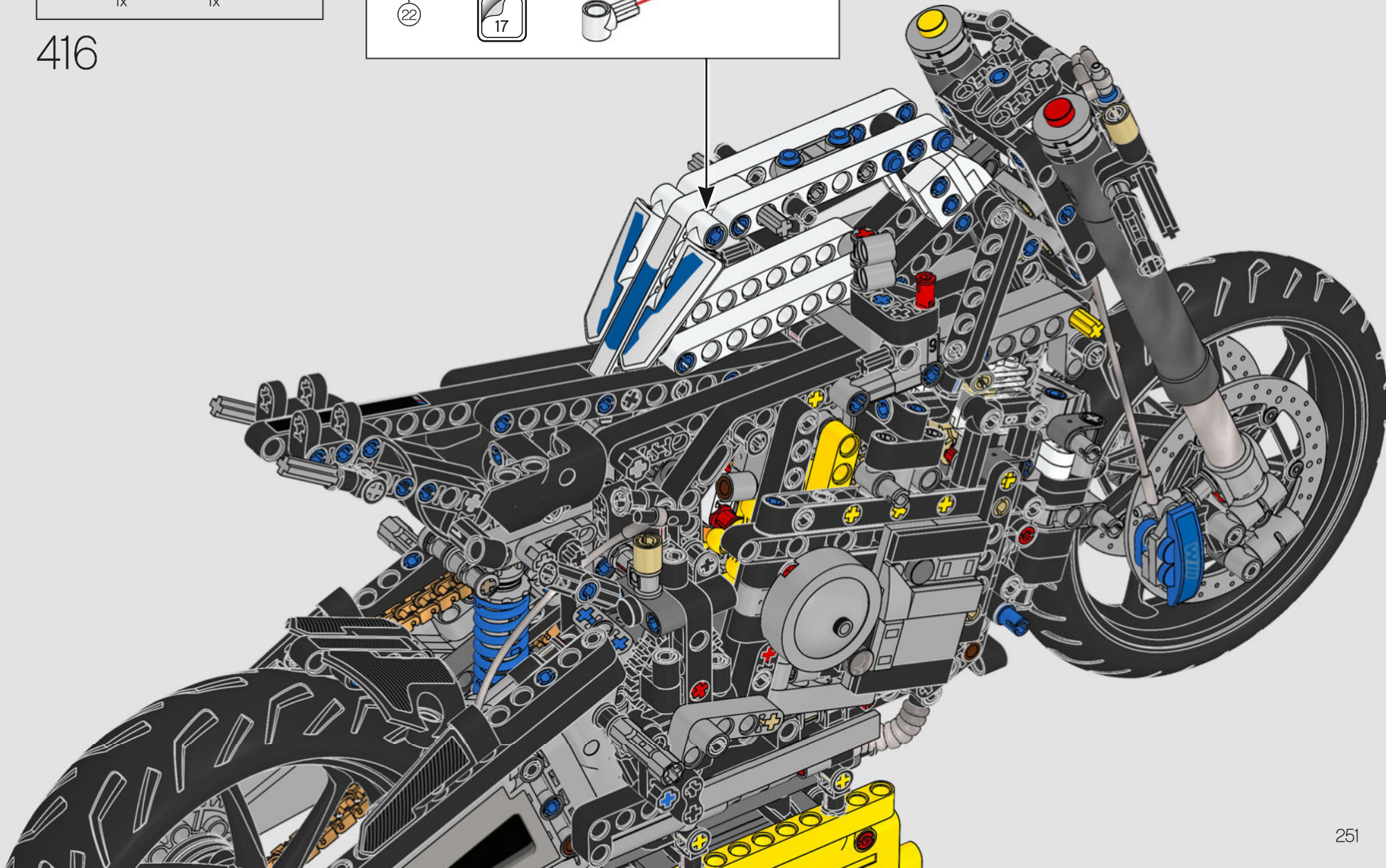

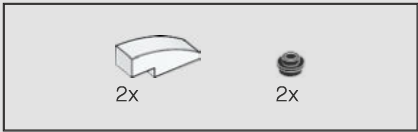

417

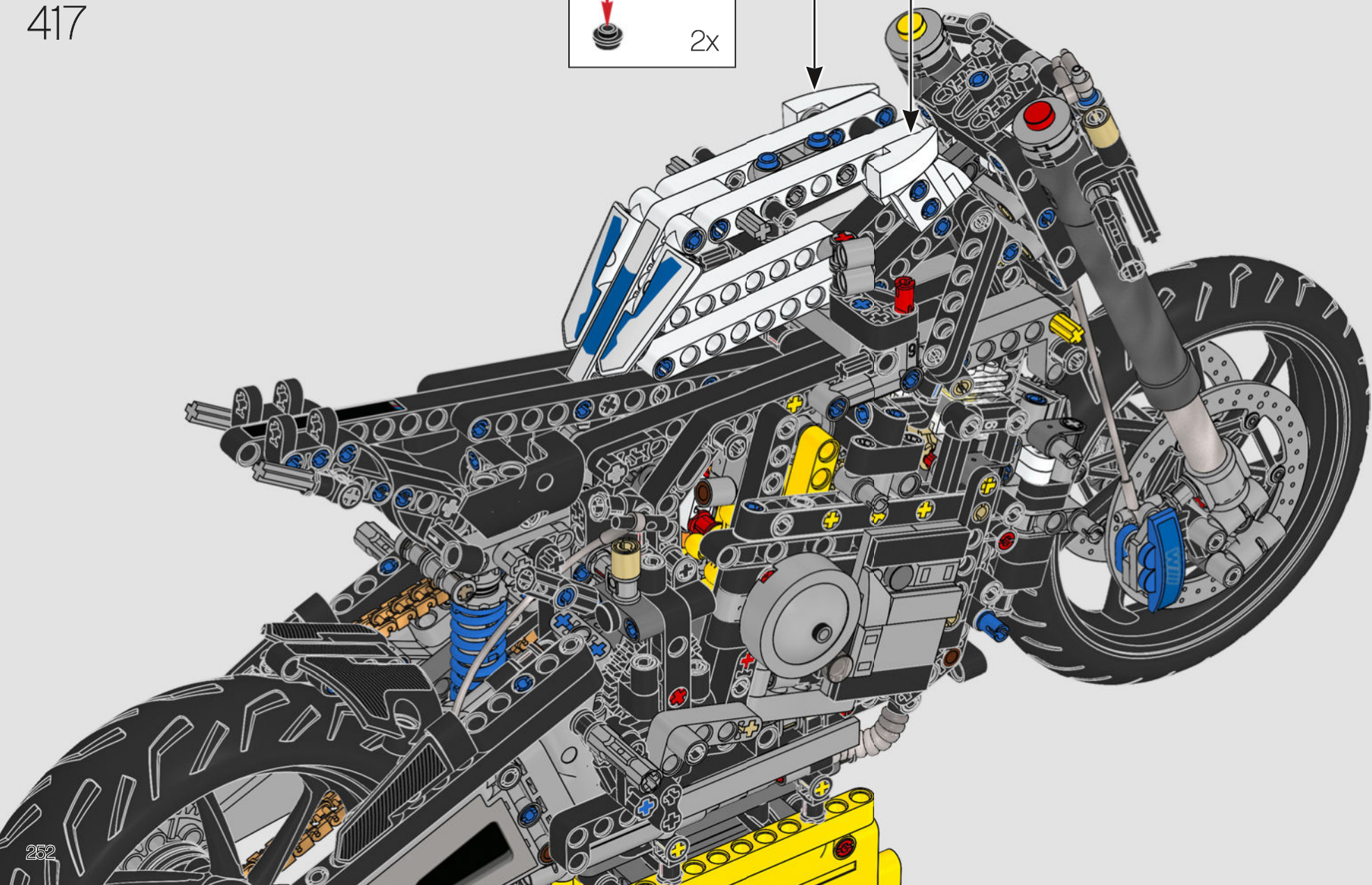
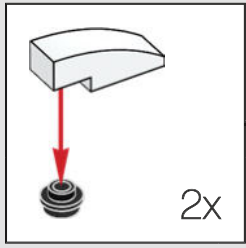



418

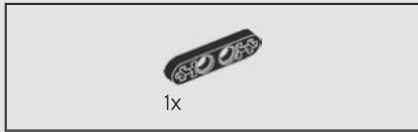

419

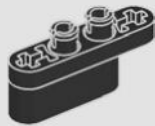

420

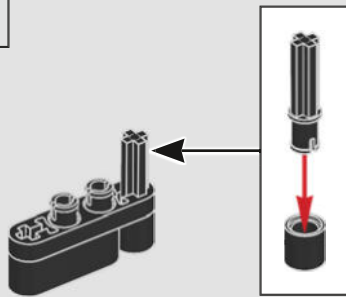

421

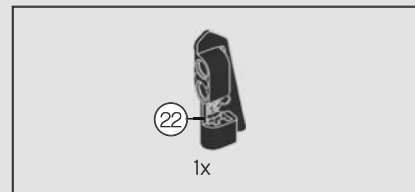
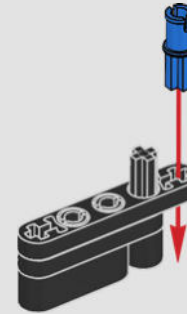

422

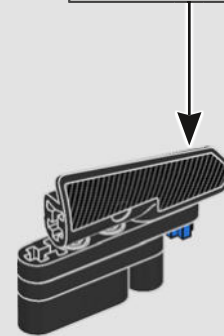
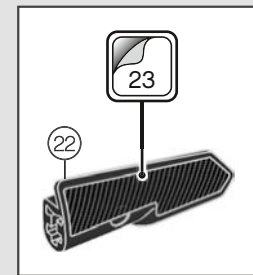

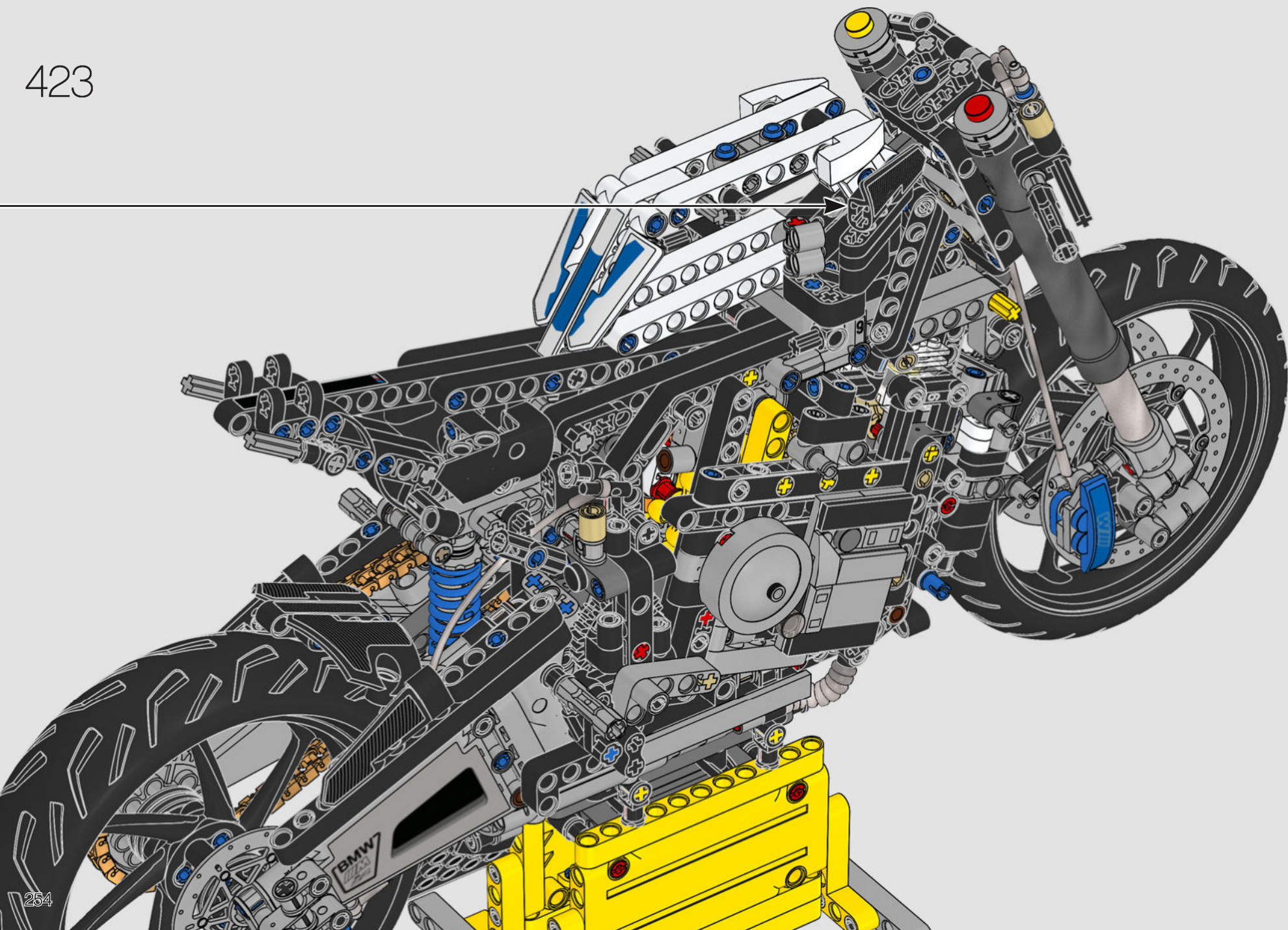

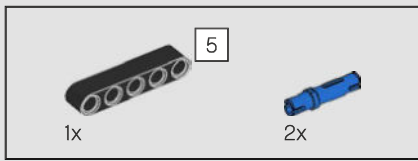

424

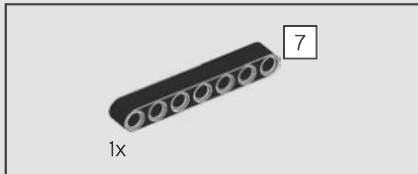
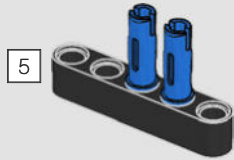

425

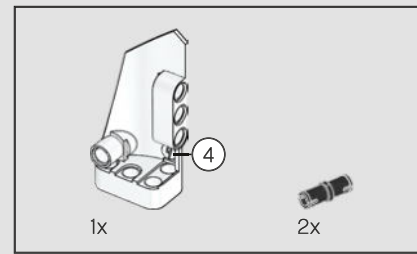
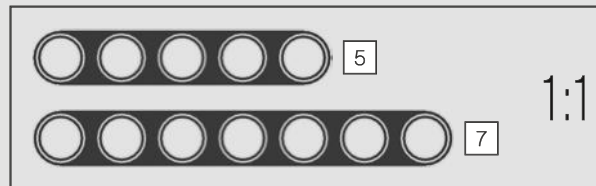
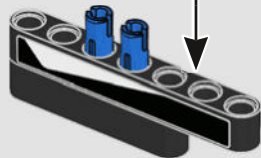
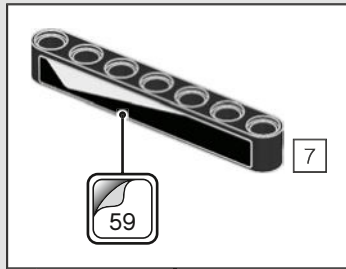

426

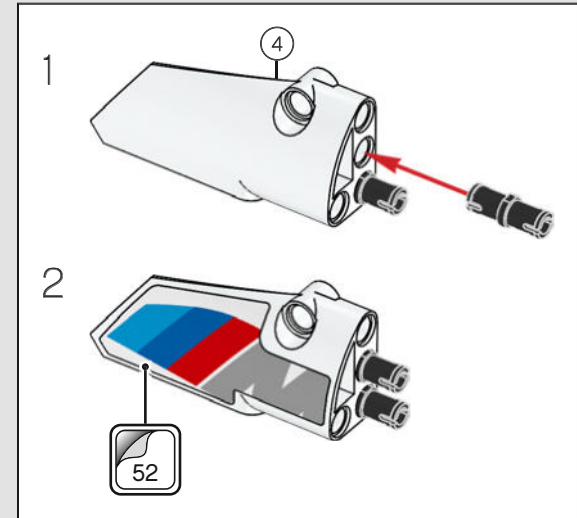

427

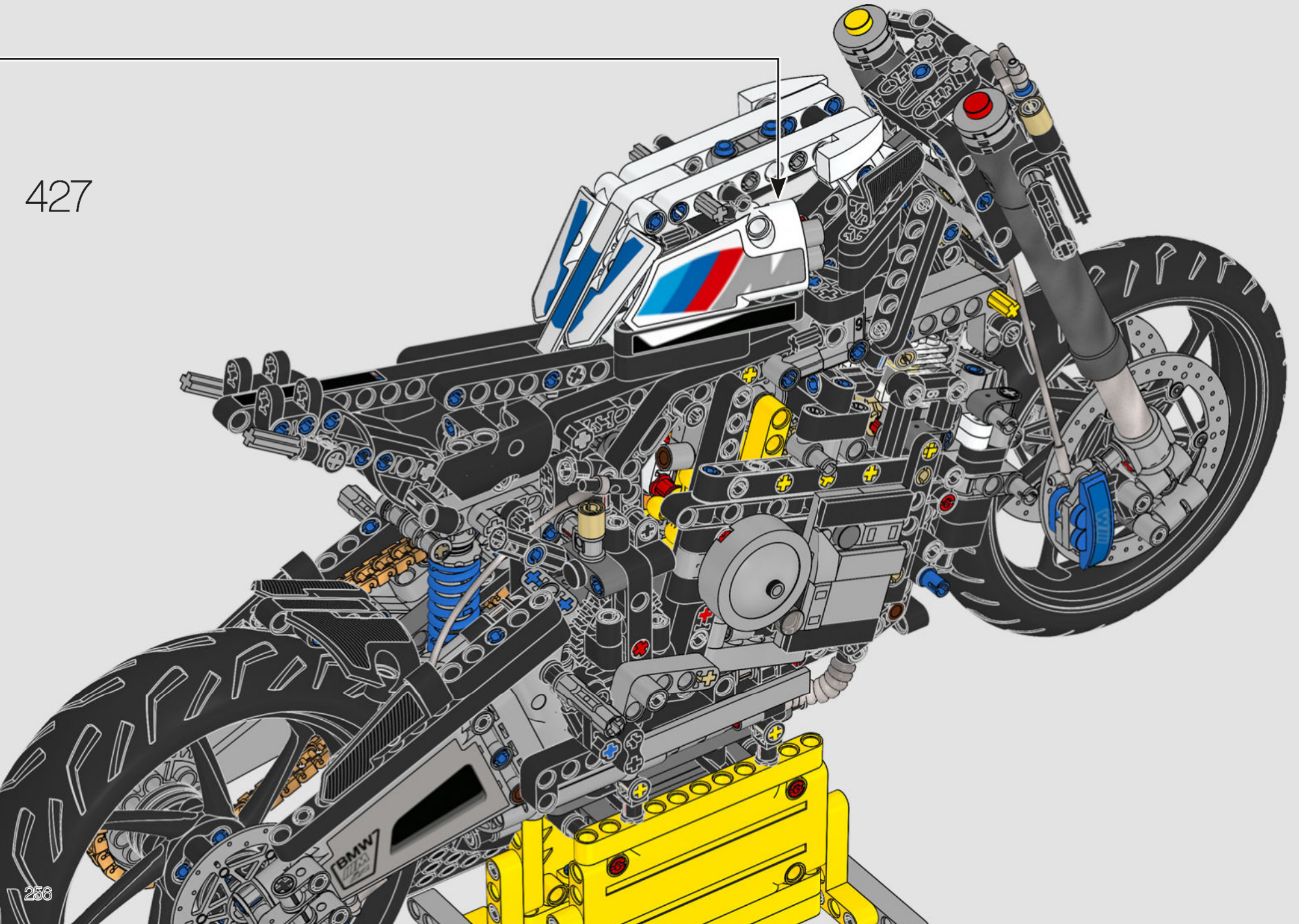

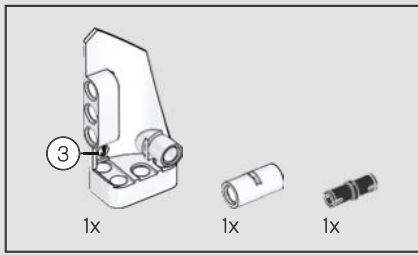

428

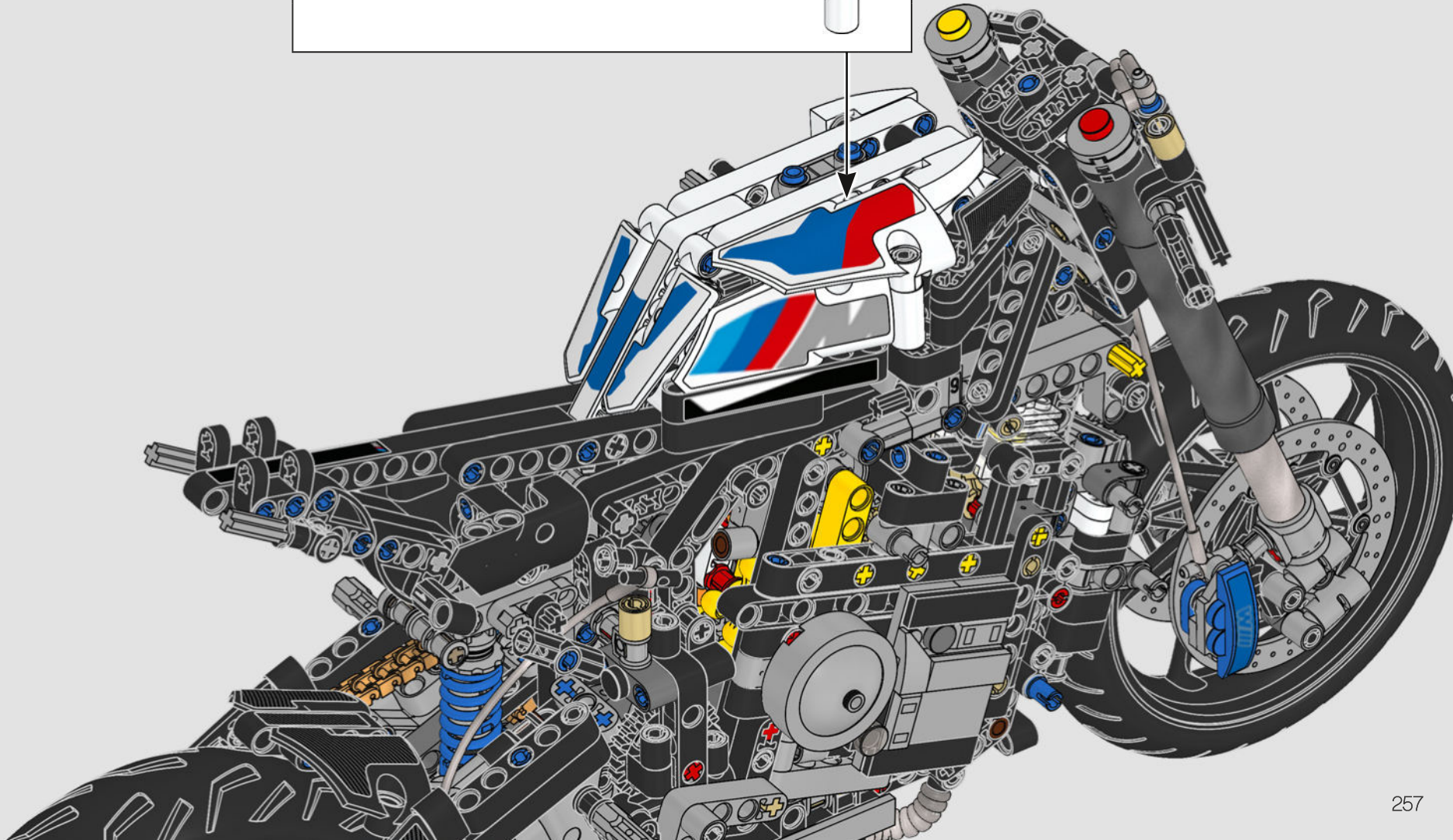
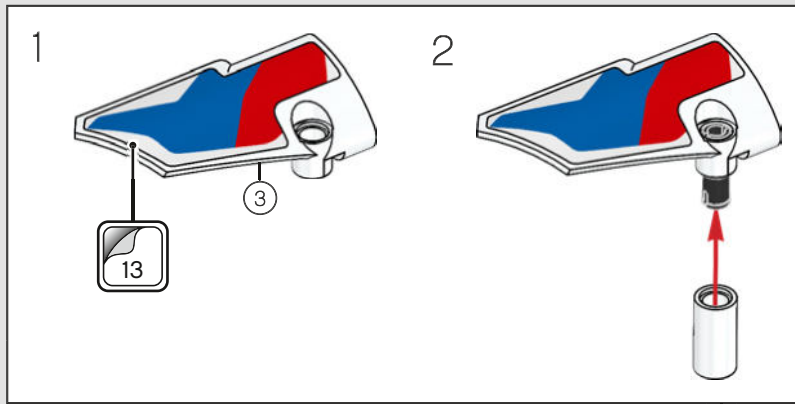

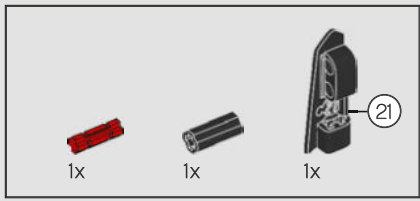

429

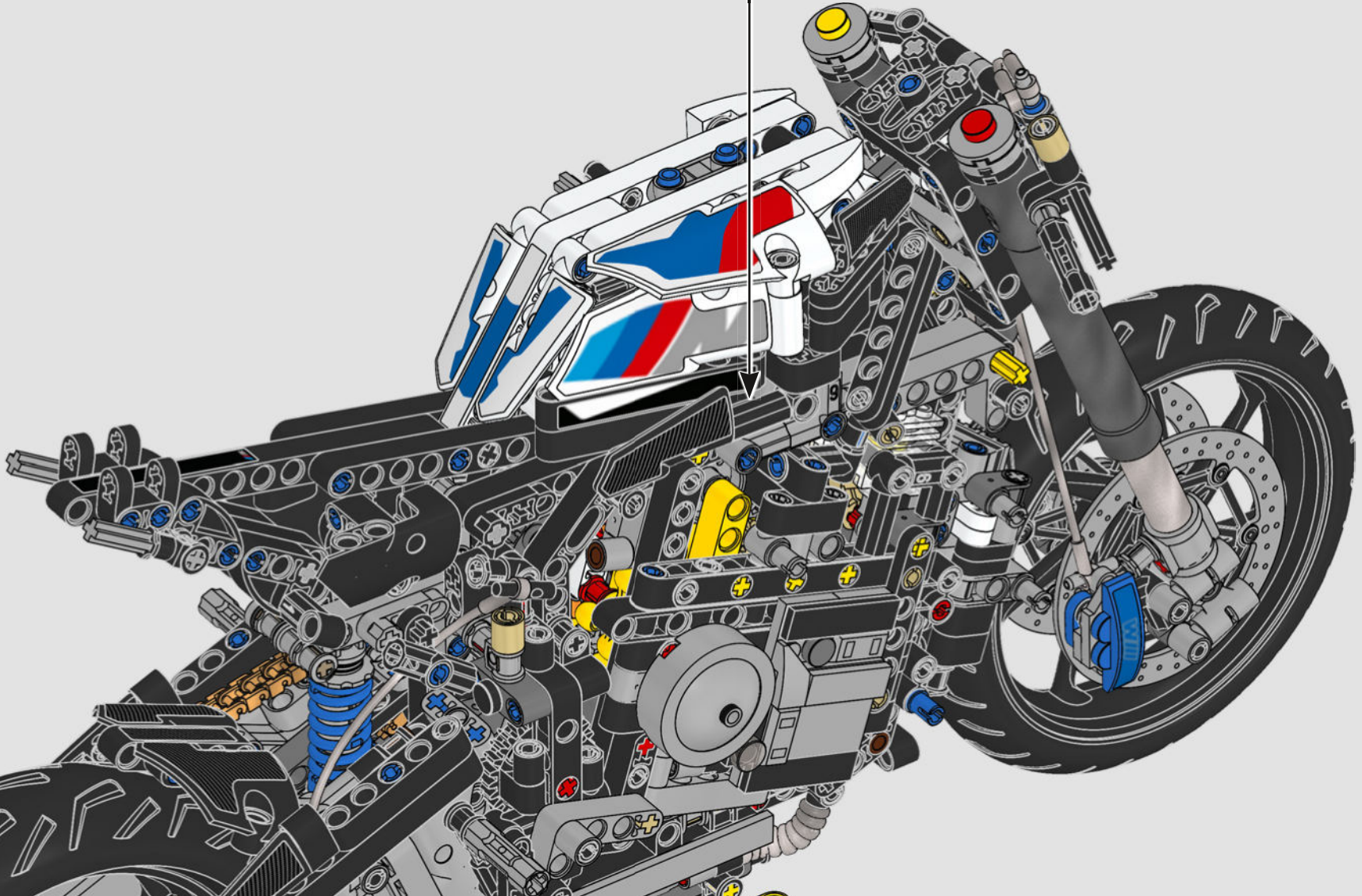
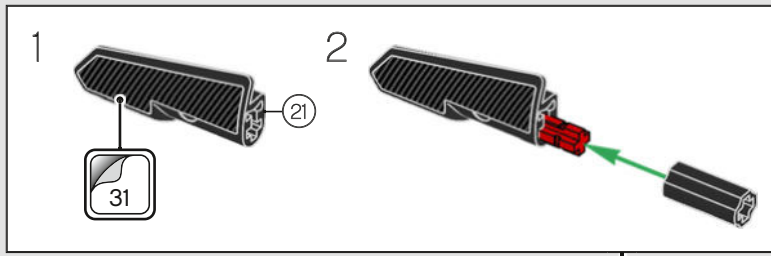

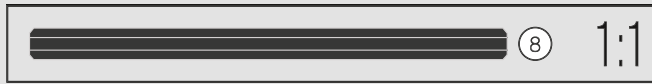
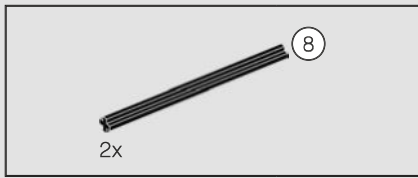

430

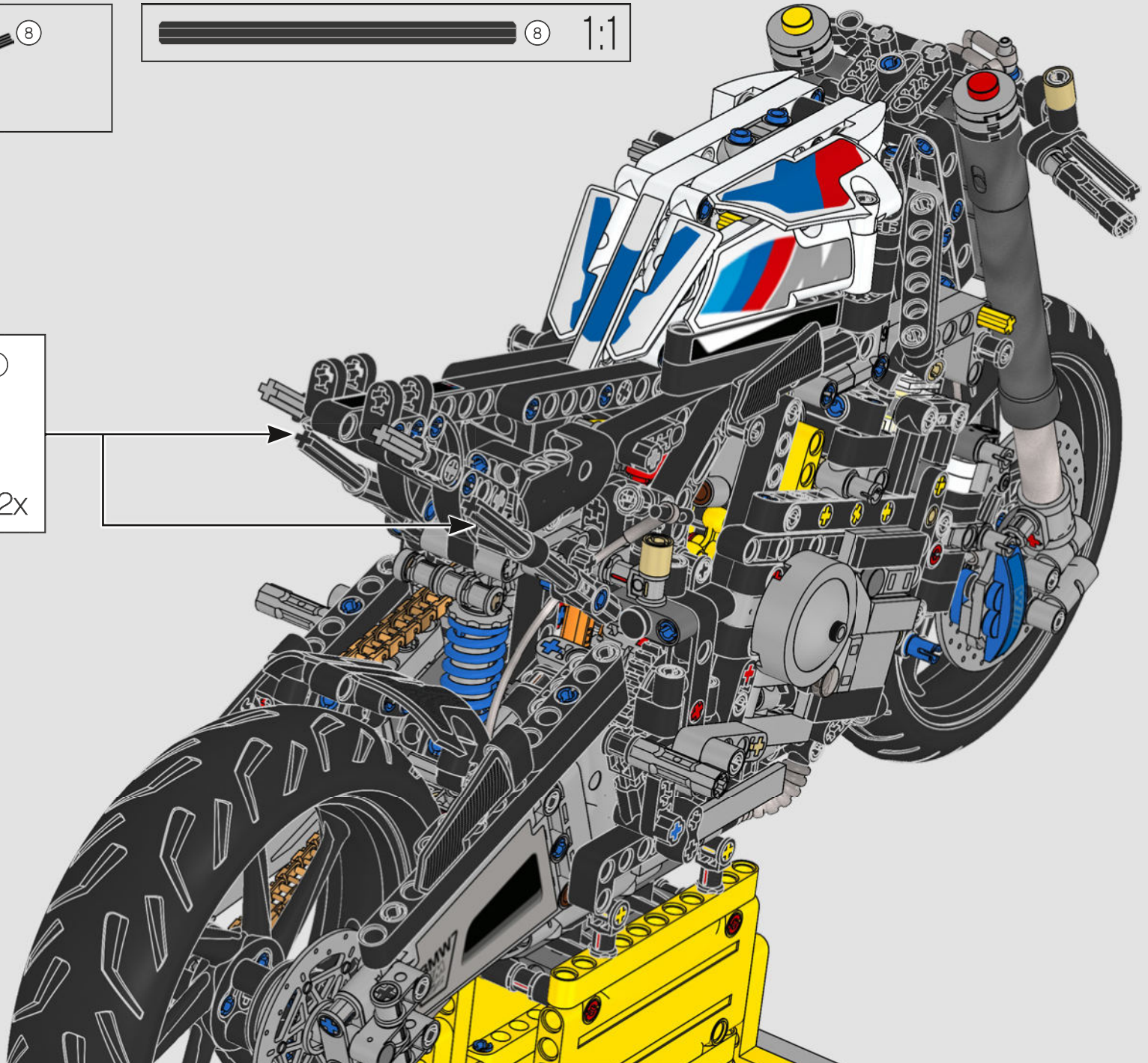
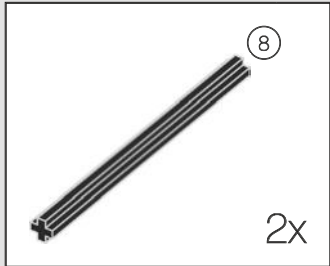

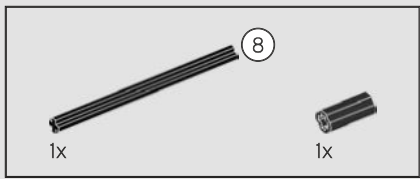

431

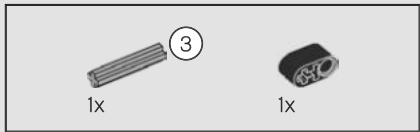
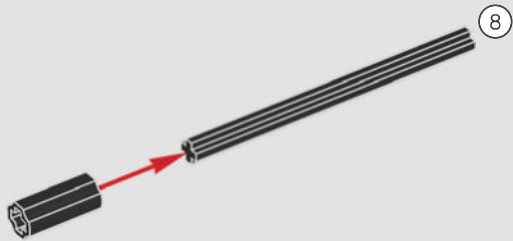

432

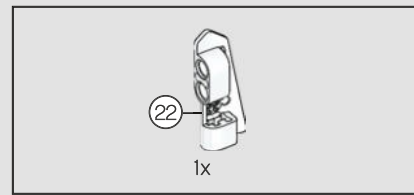
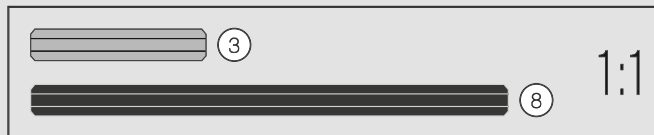
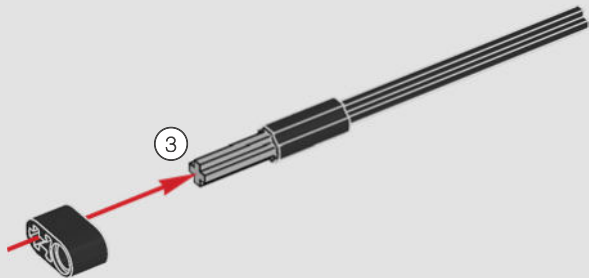

433

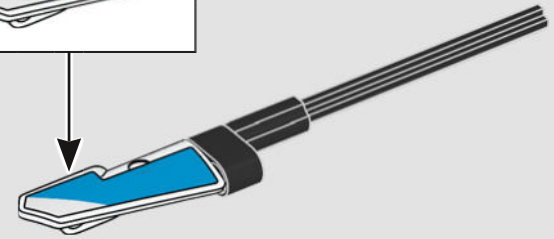
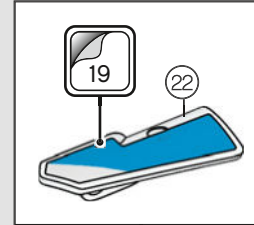

434

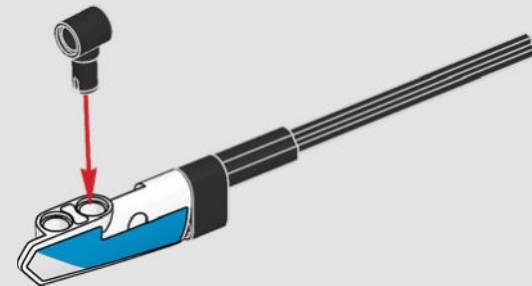

435

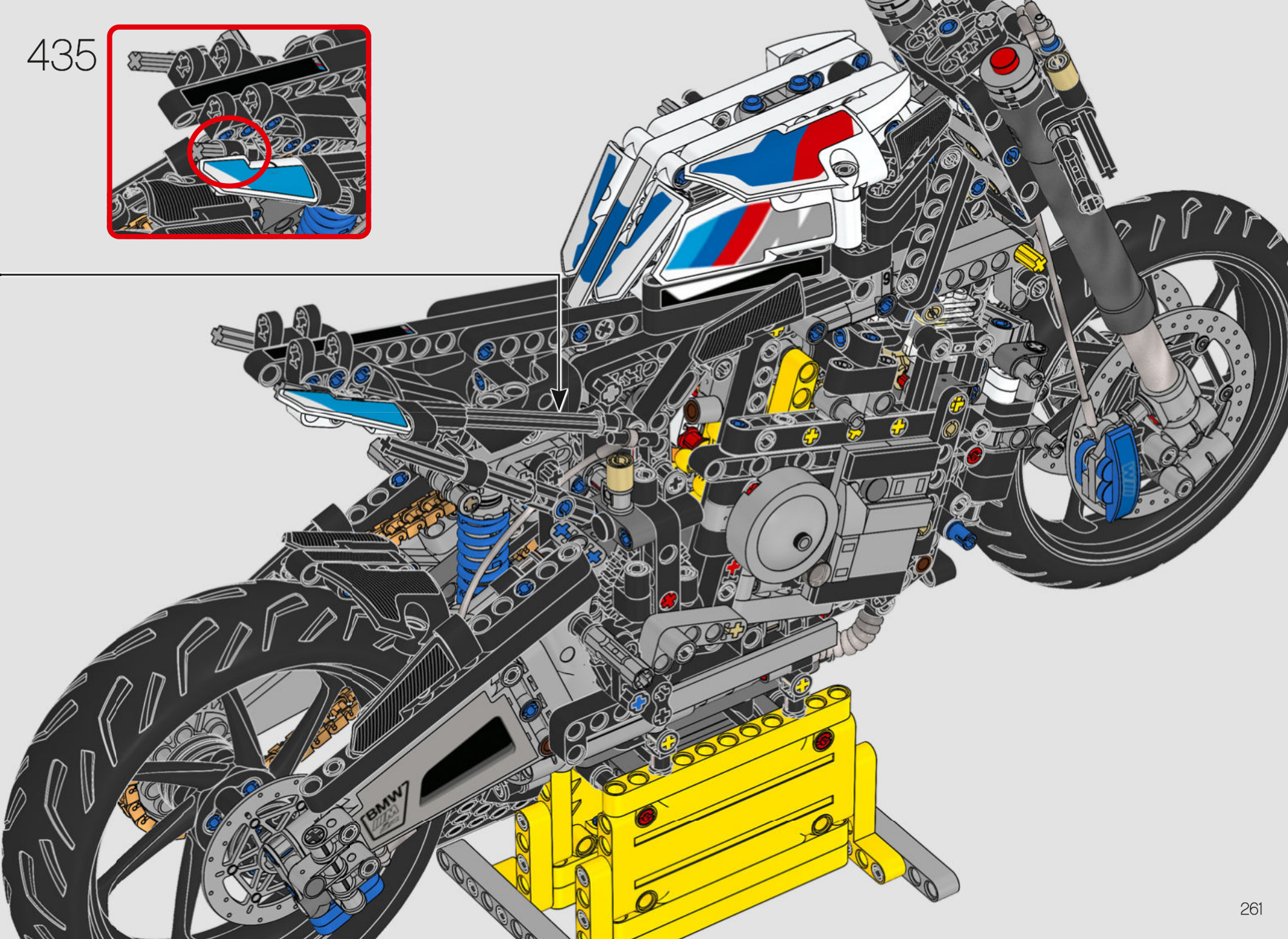
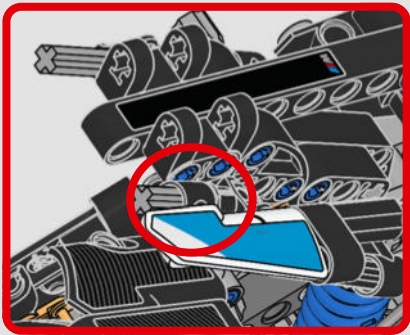

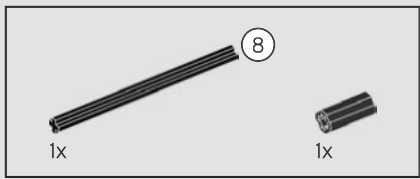

436

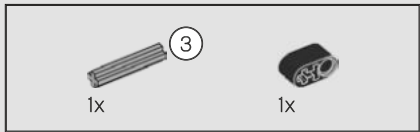
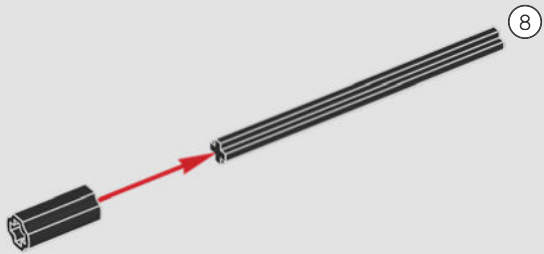

437

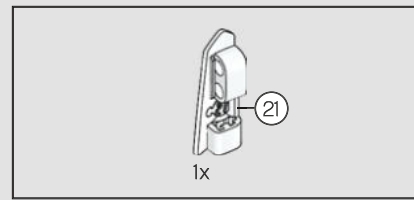
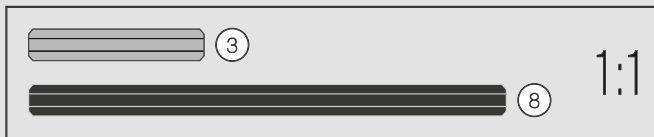
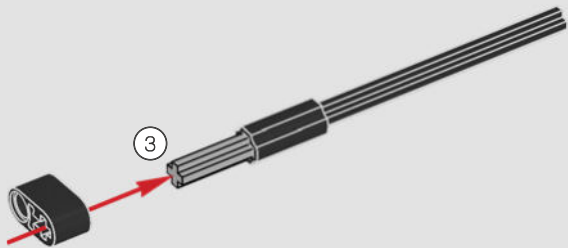

438

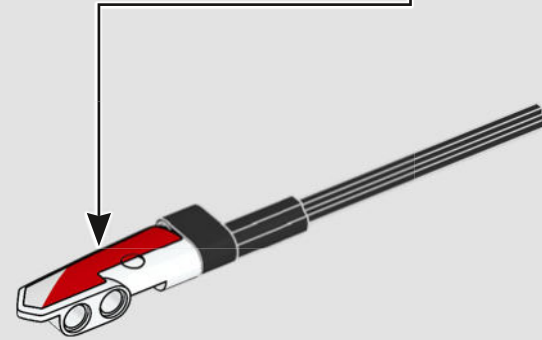
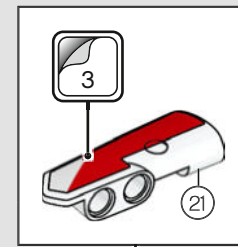

439

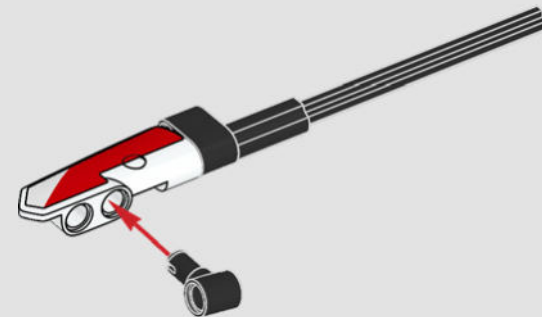

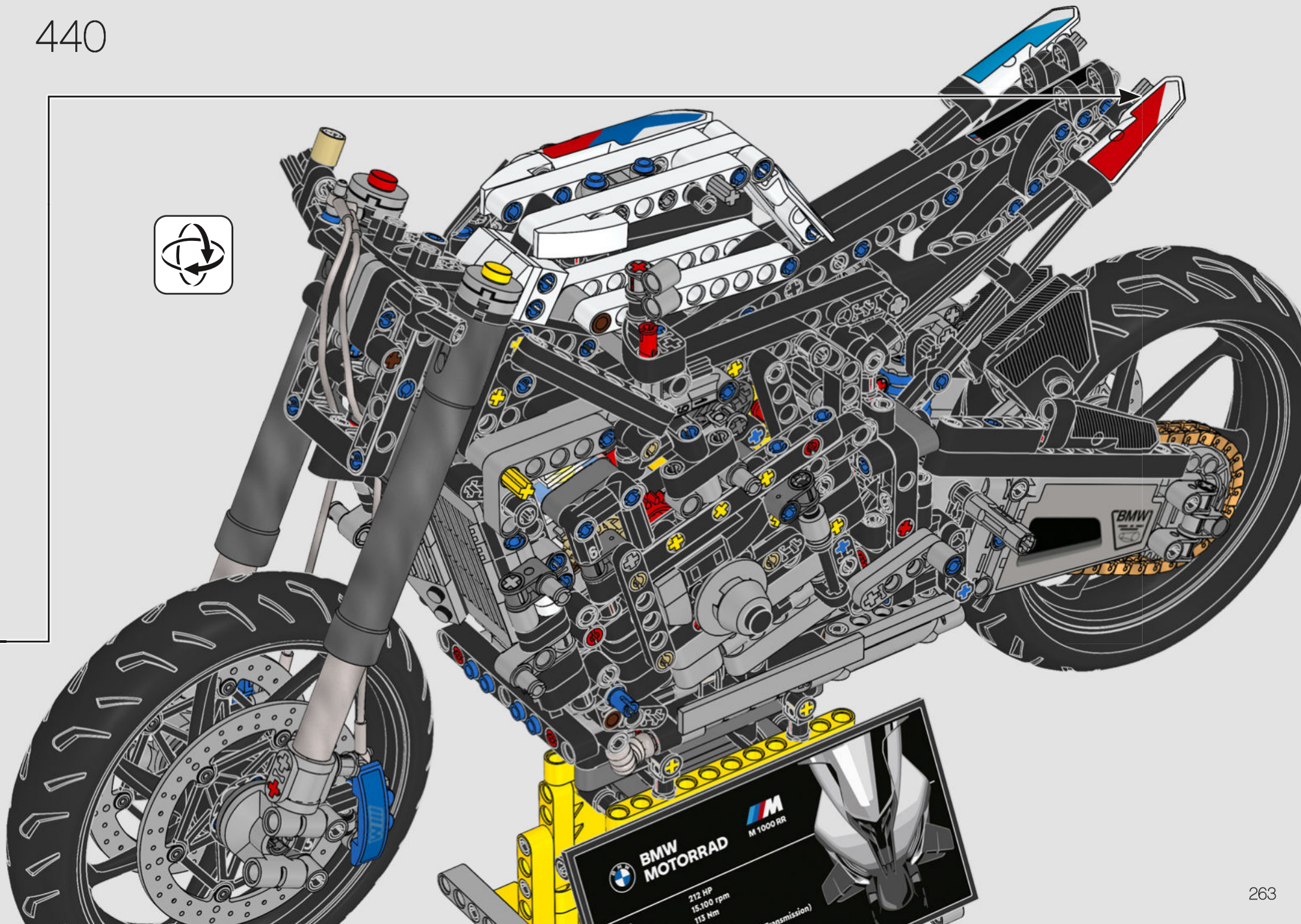

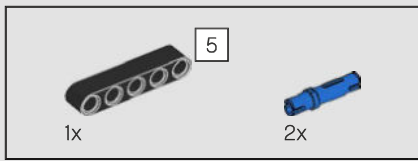

441

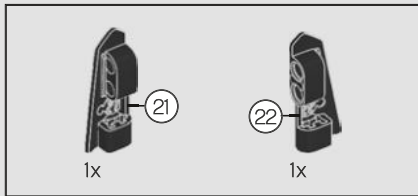
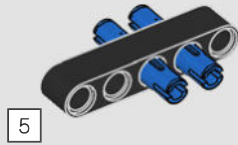

442

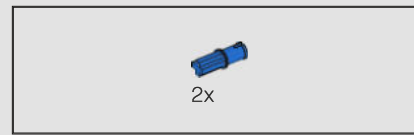
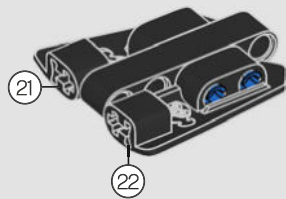

443

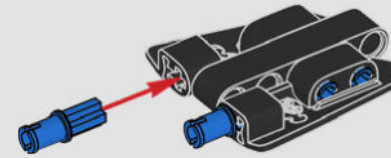

444

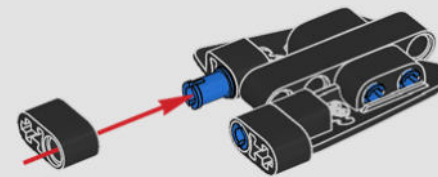

445

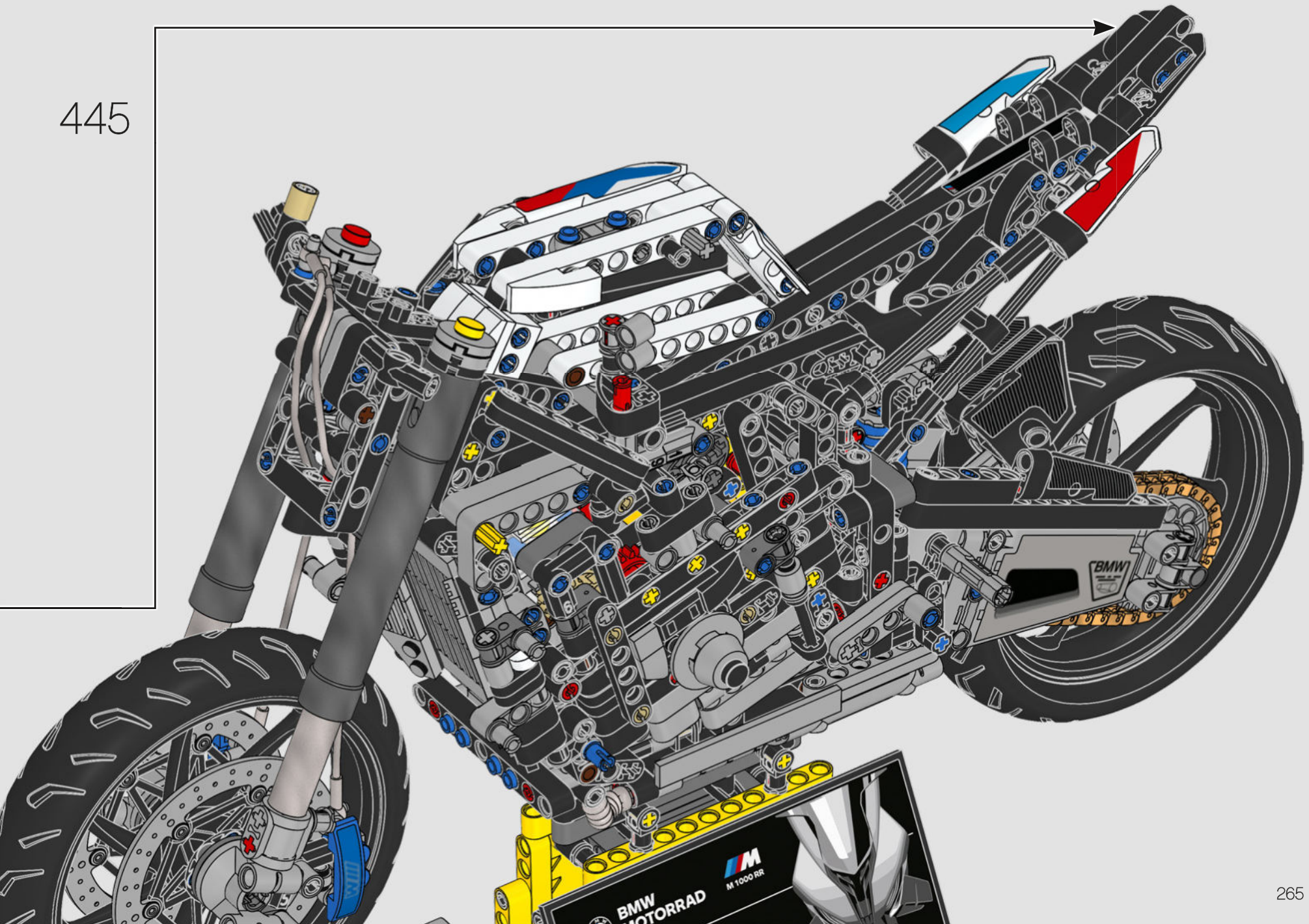



446

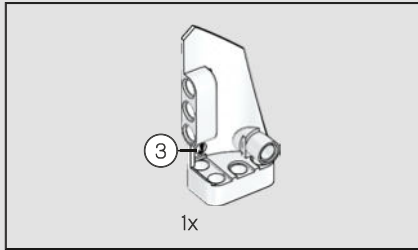
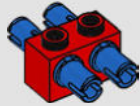

447

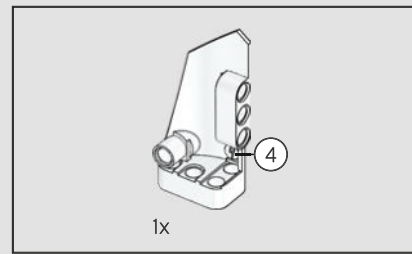
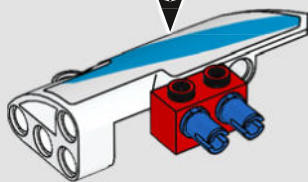
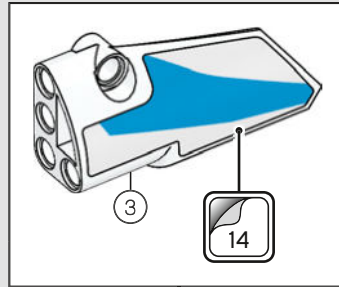

448

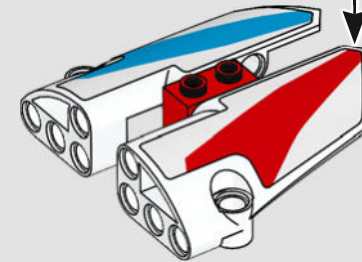
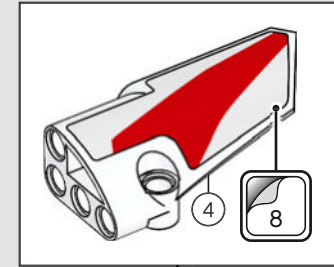

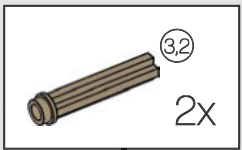
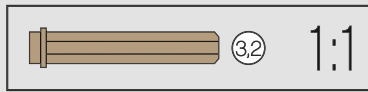
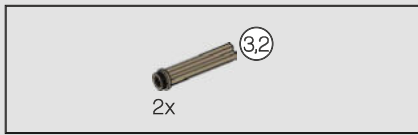

449

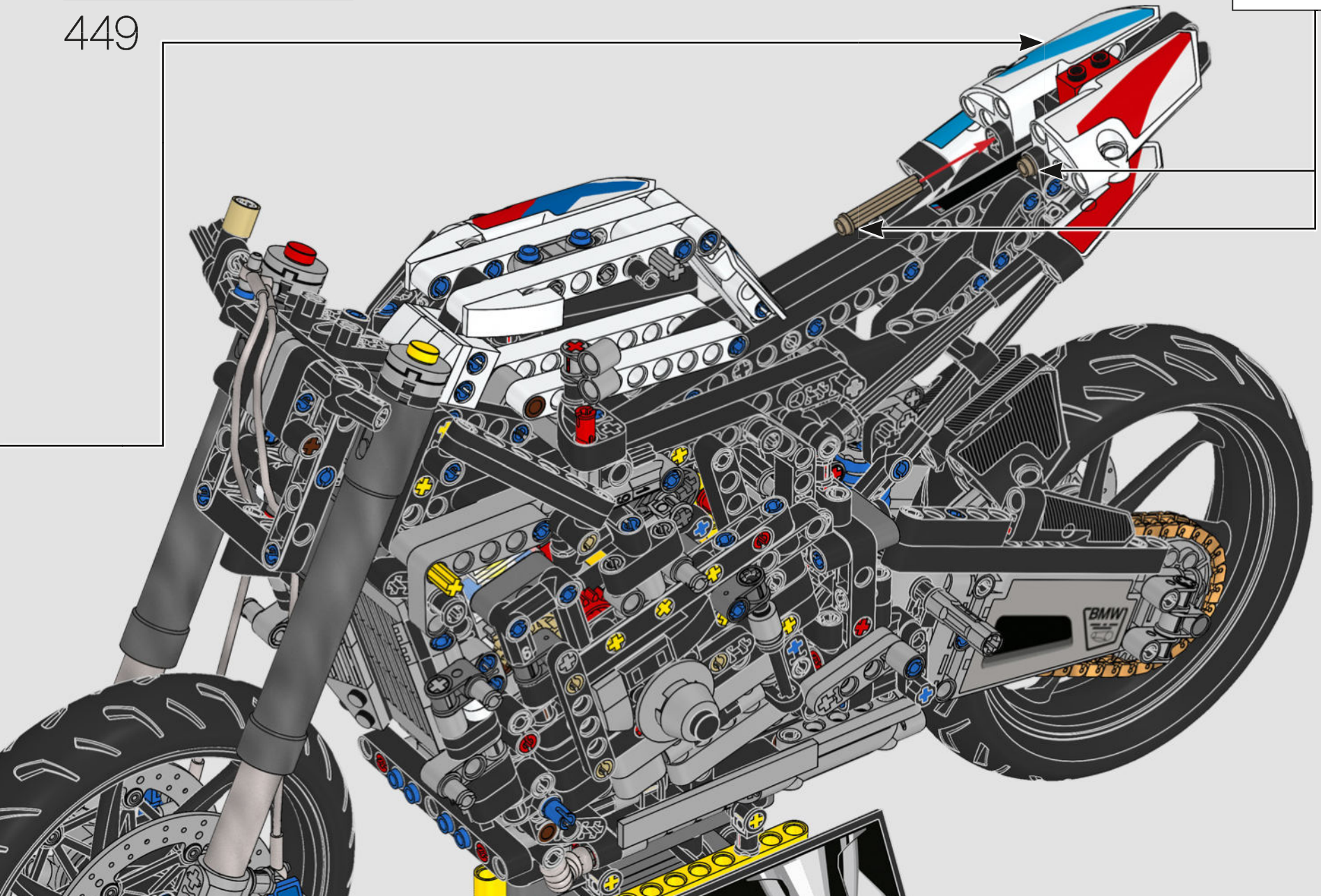

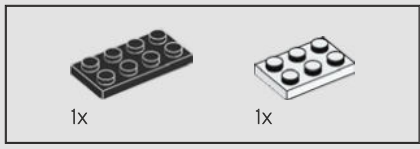

450

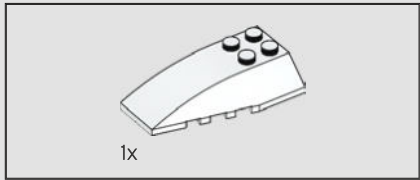
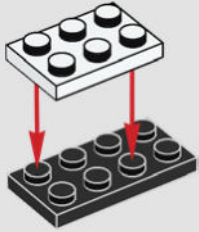

451

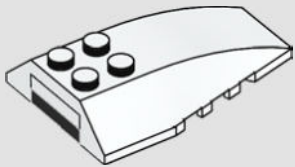

452

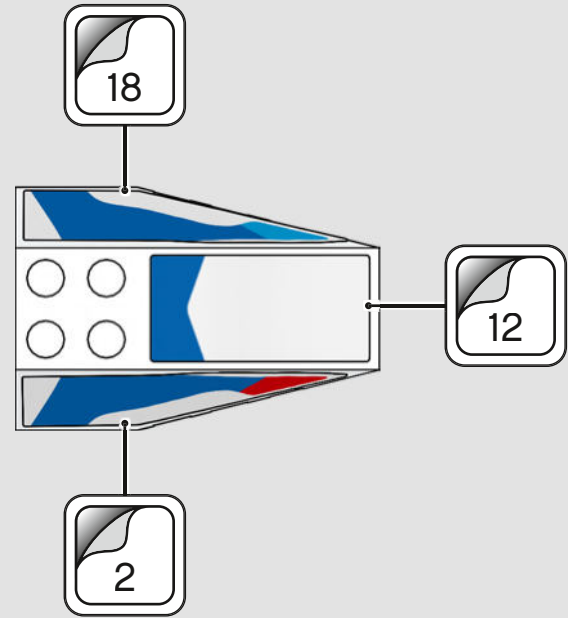

453

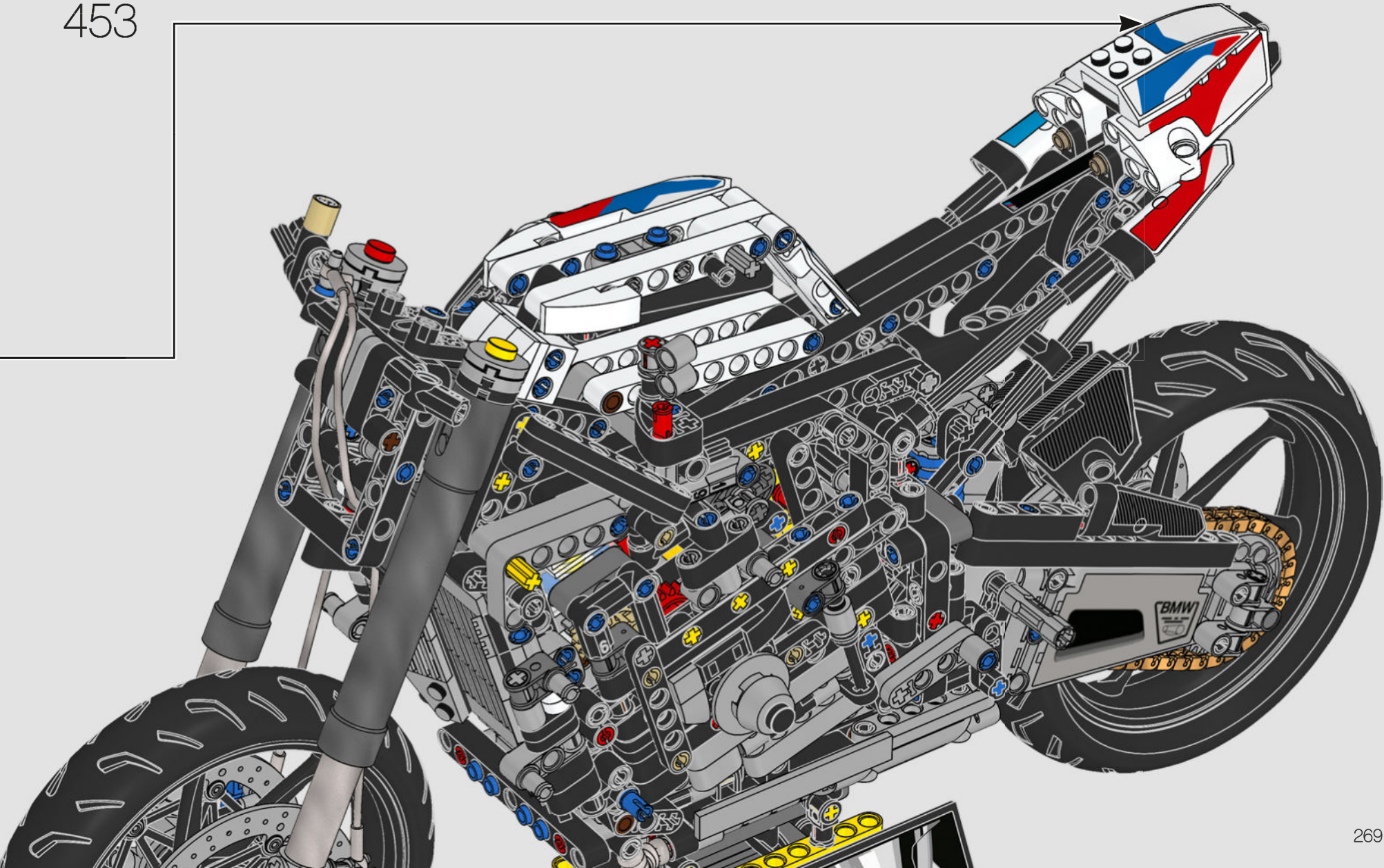



454

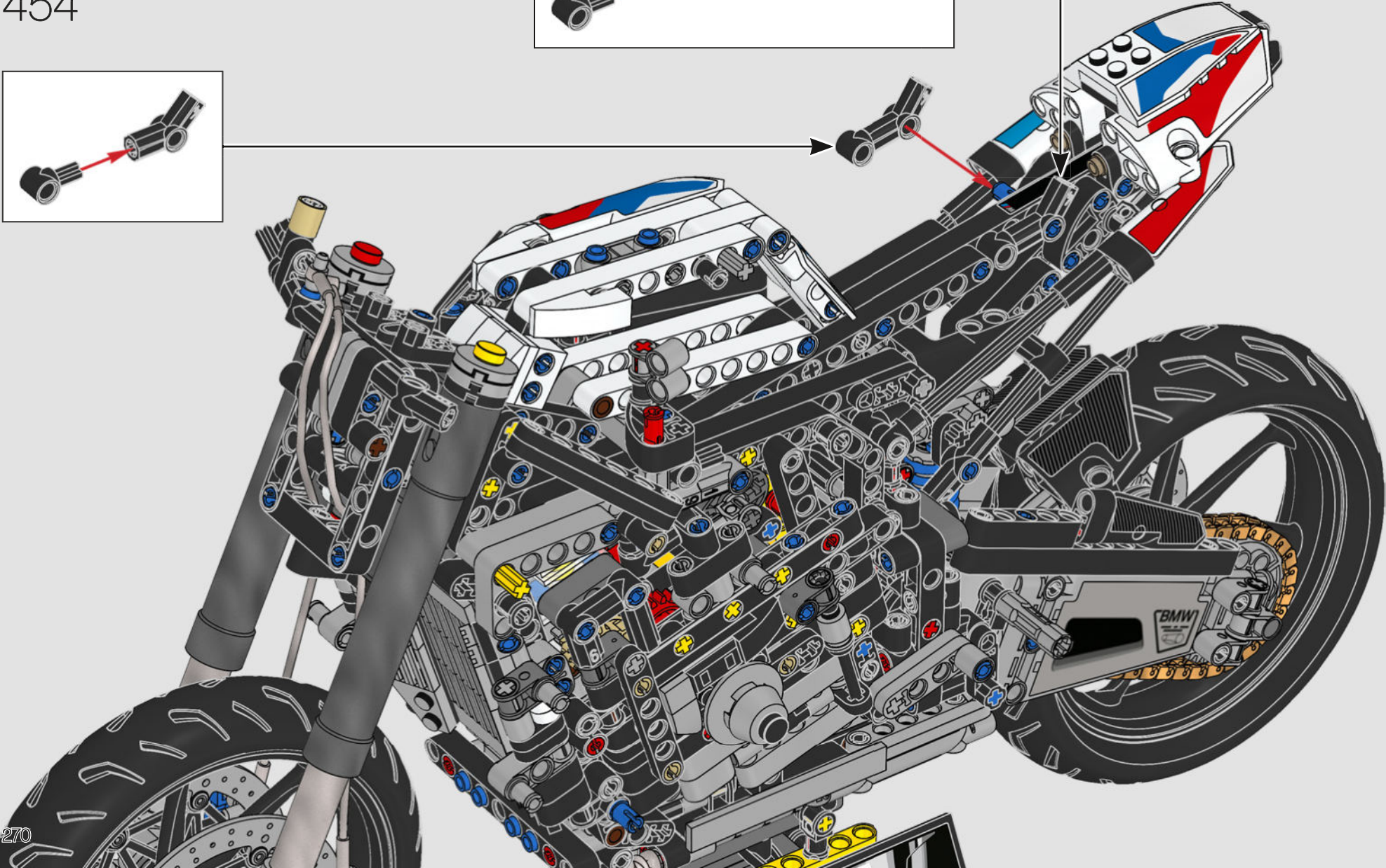
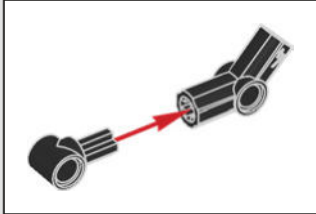
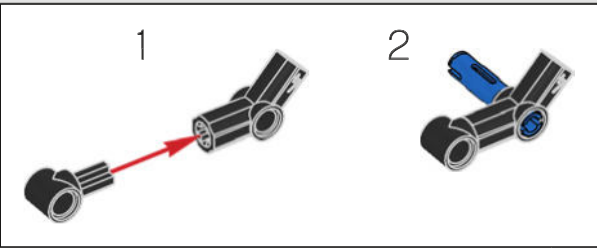

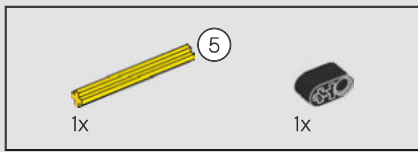

455



456

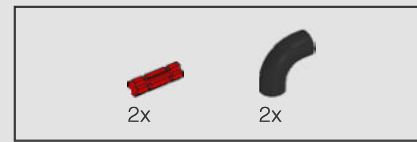
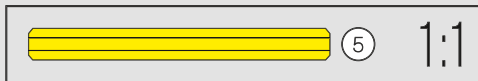
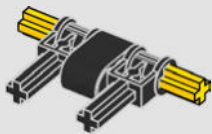

457

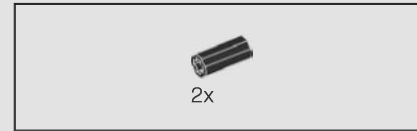
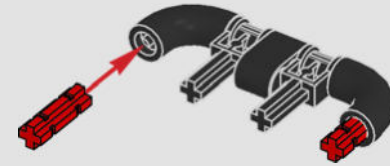

458

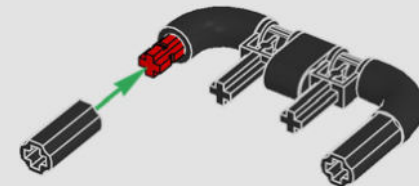

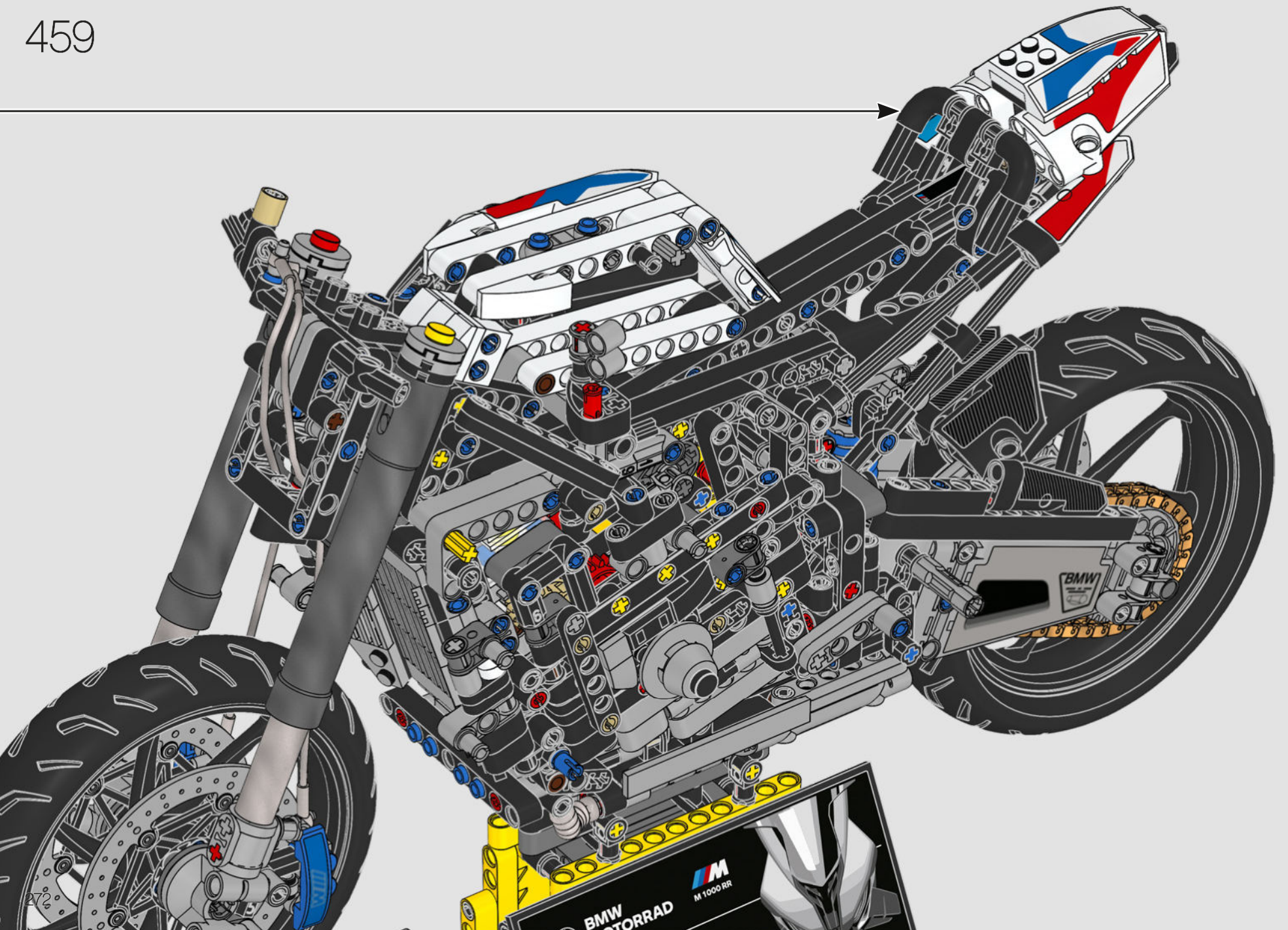

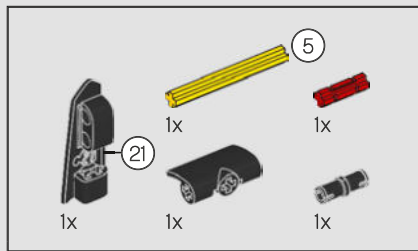

460

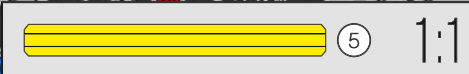
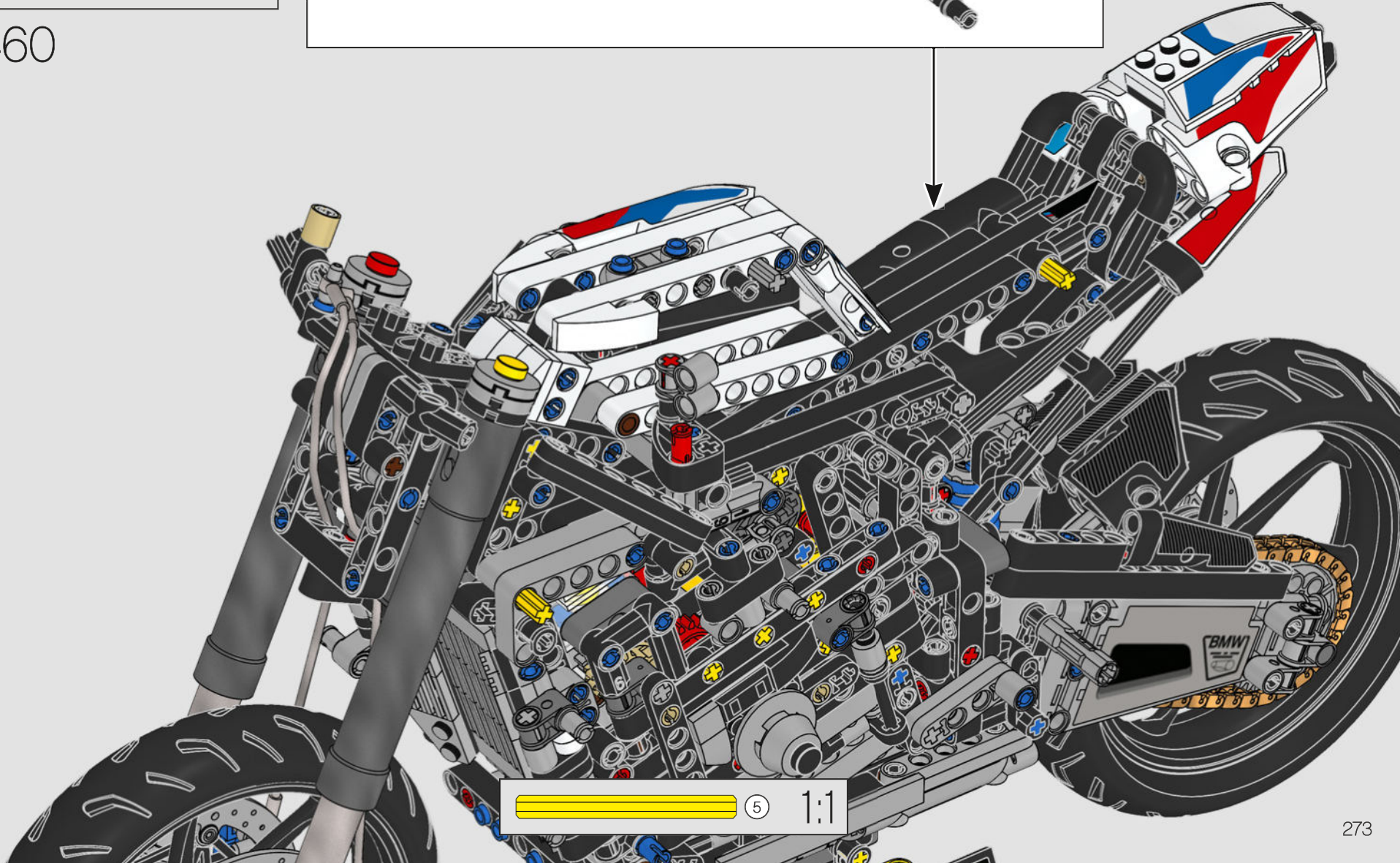
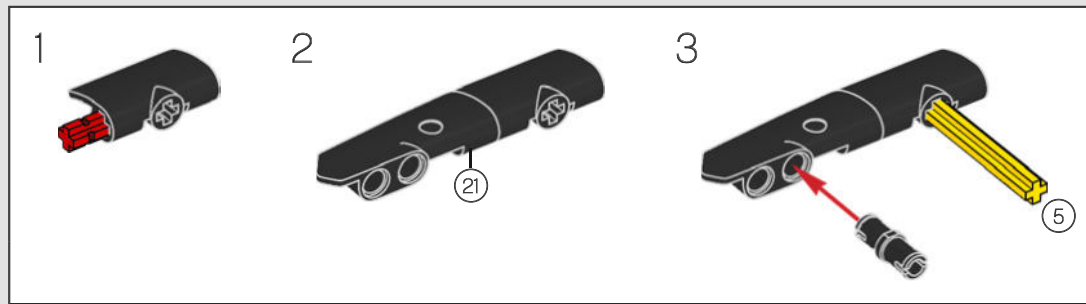

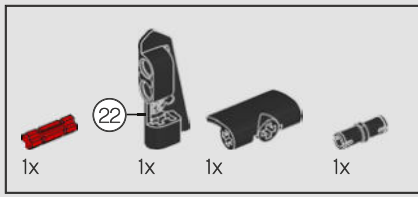

461

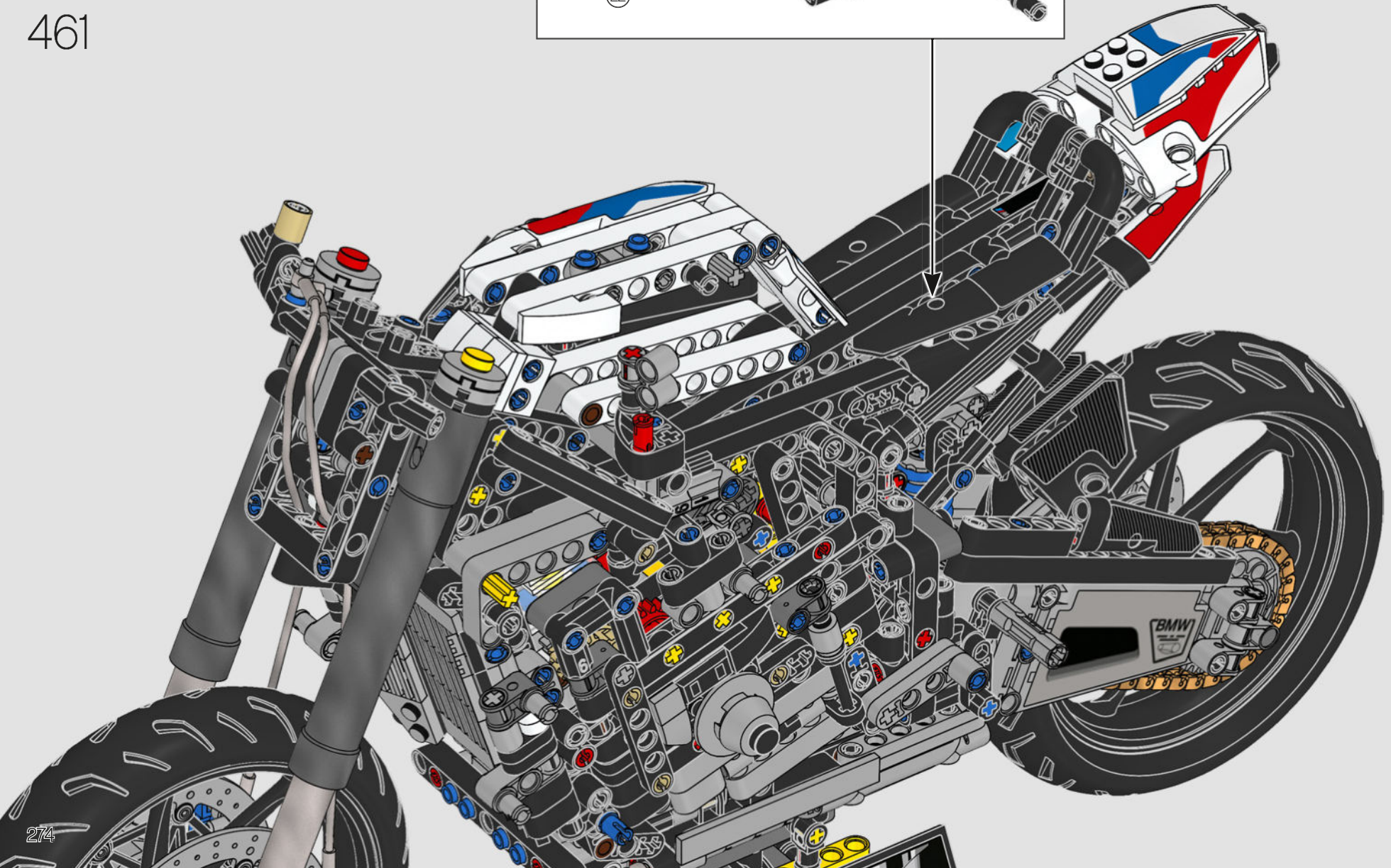
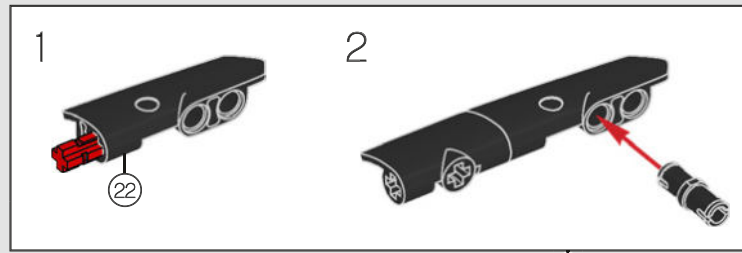

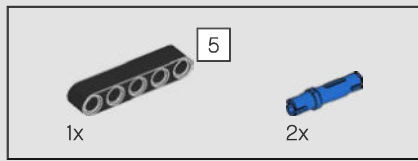

462

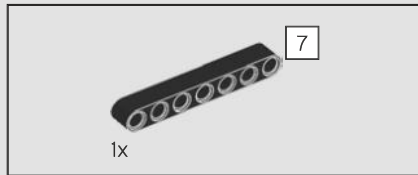
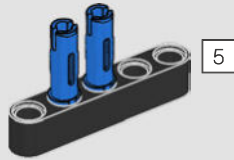

463

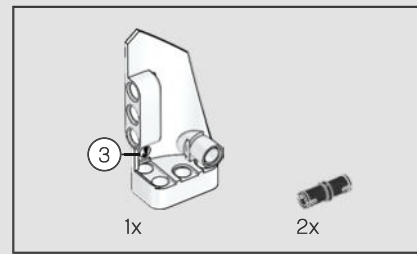
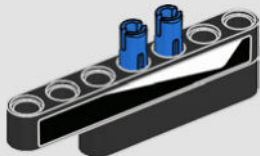
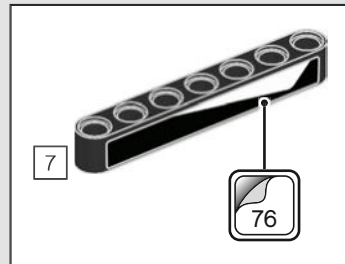

464

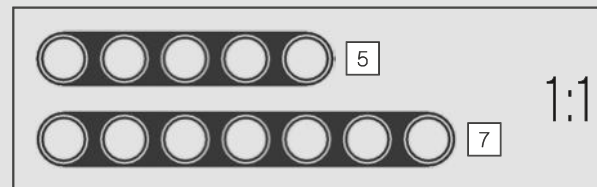
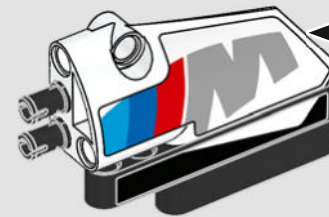
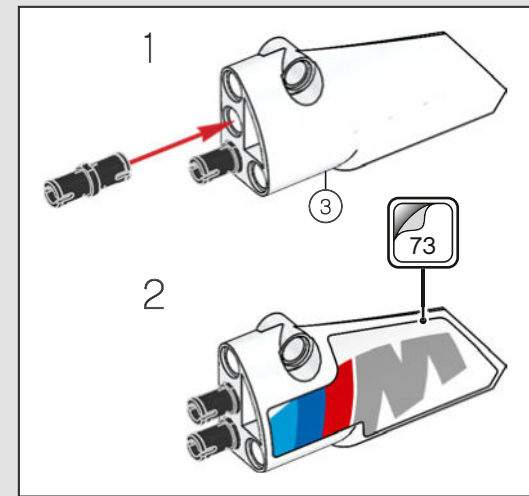

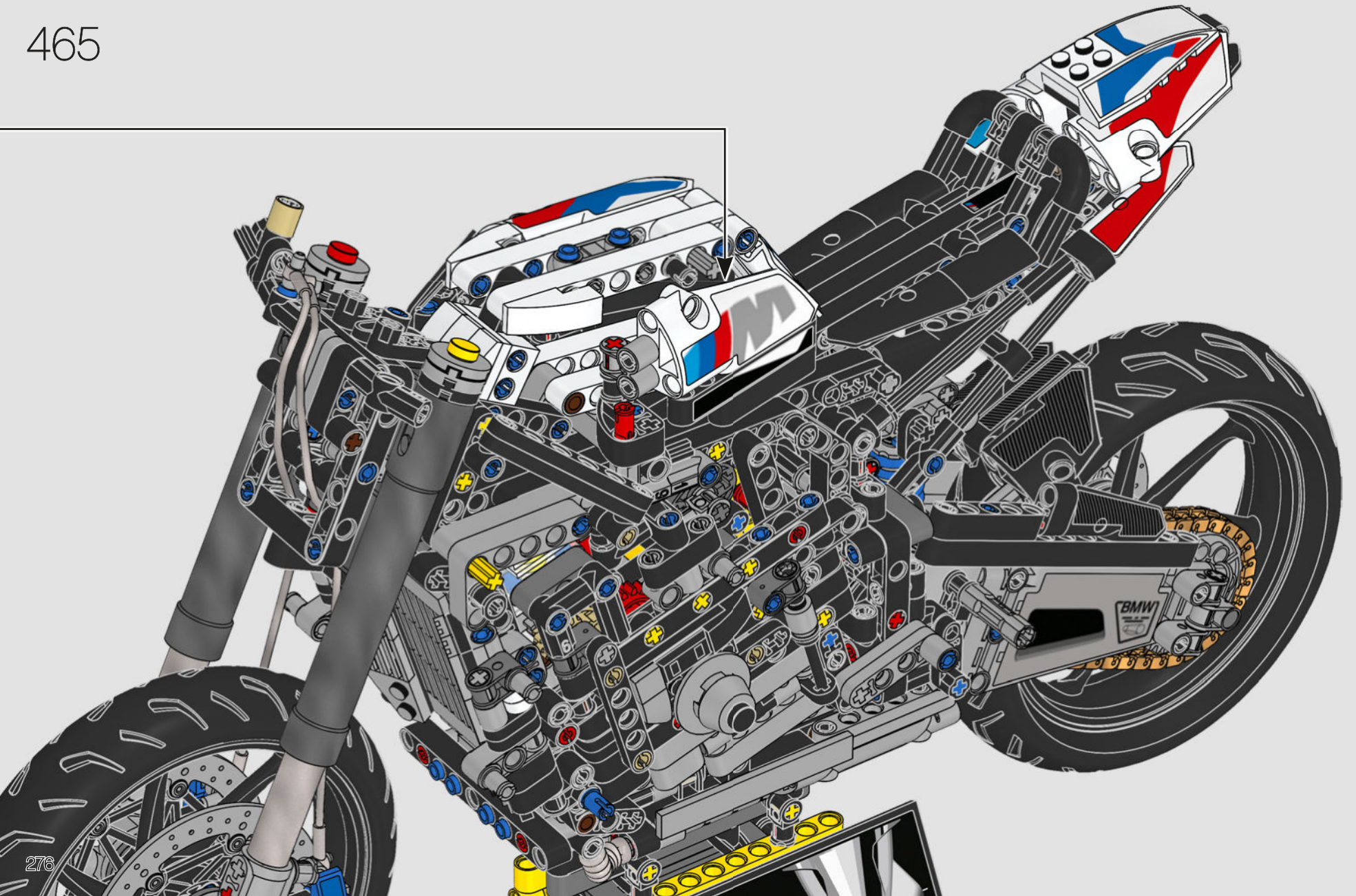



466

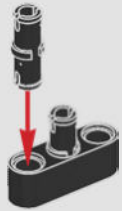

467

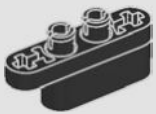

468

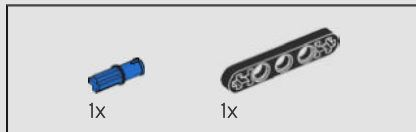
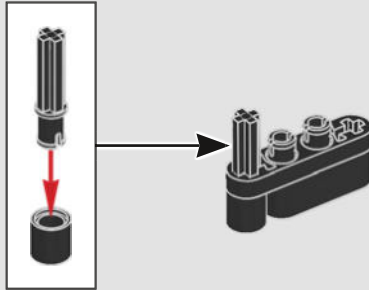

469

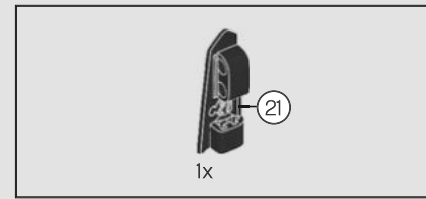
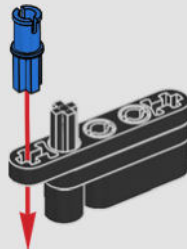

470

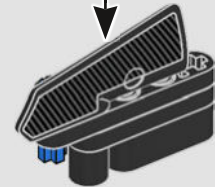
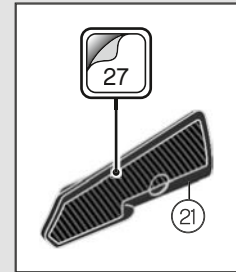

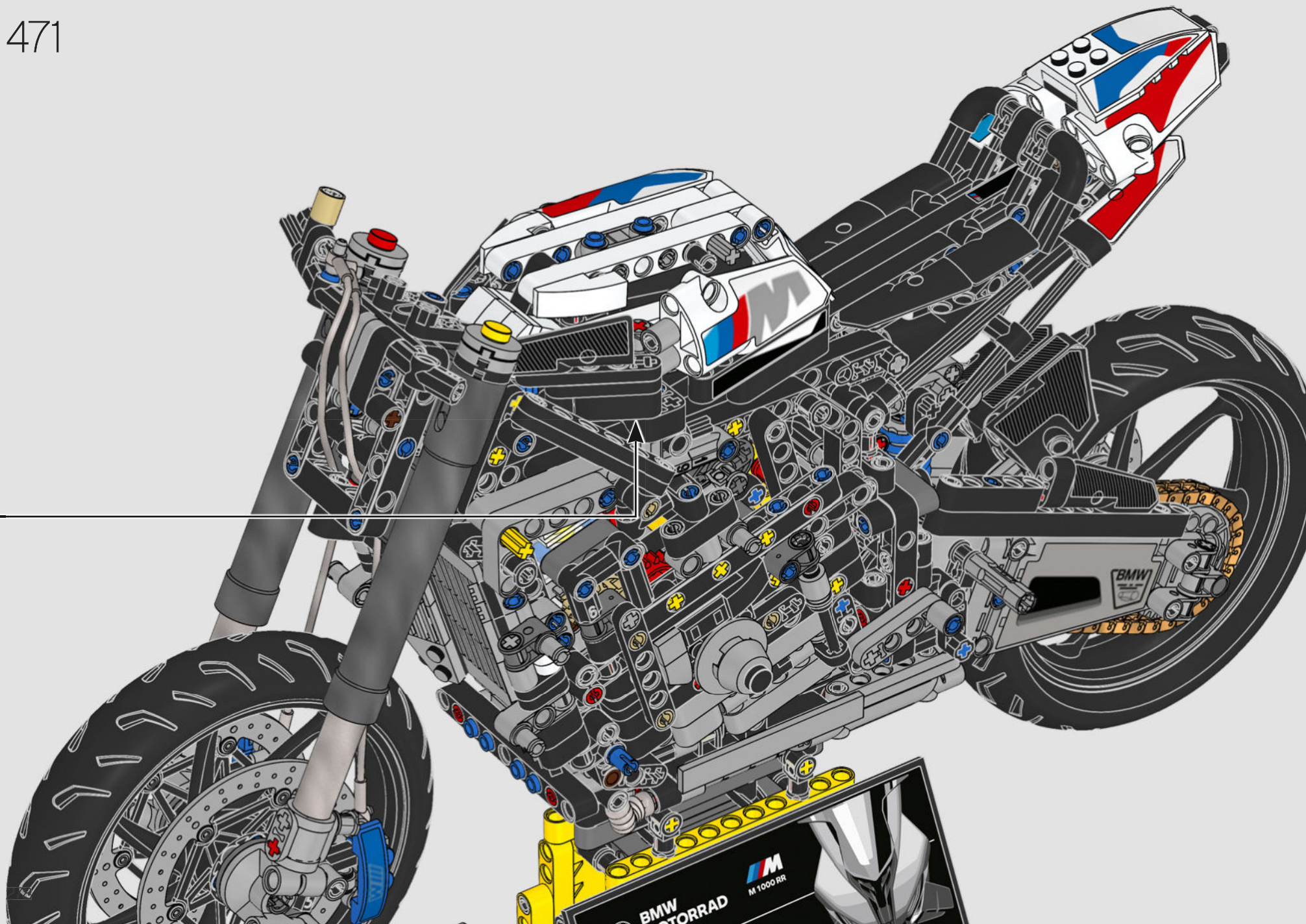

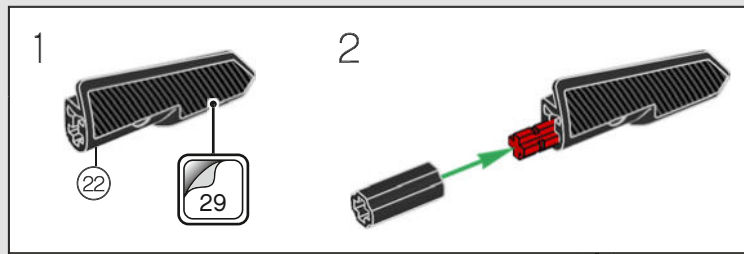
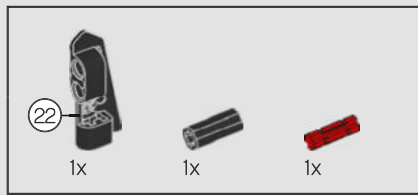

472

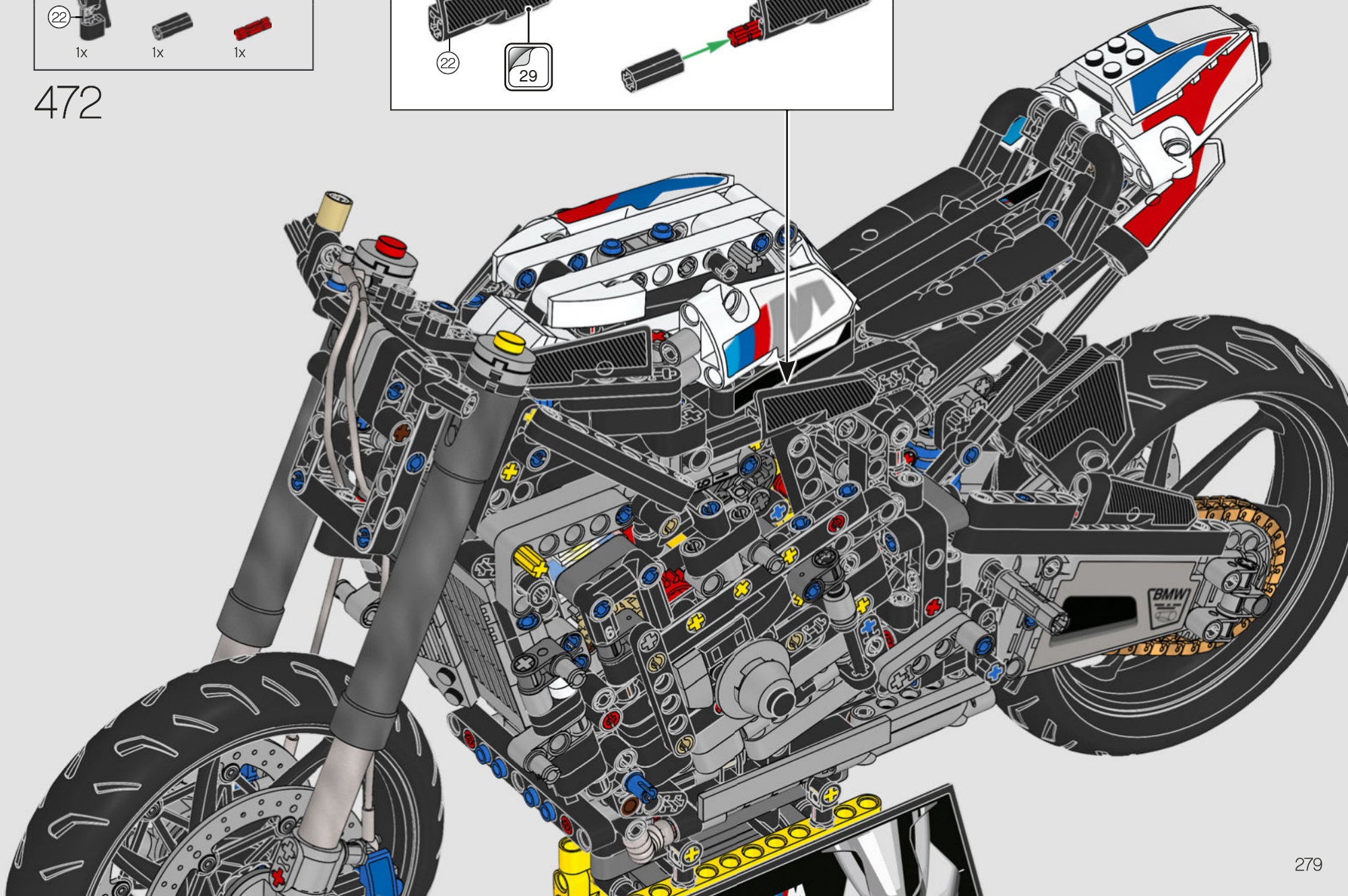

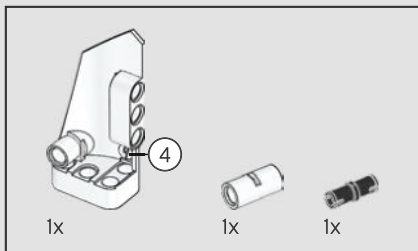

473

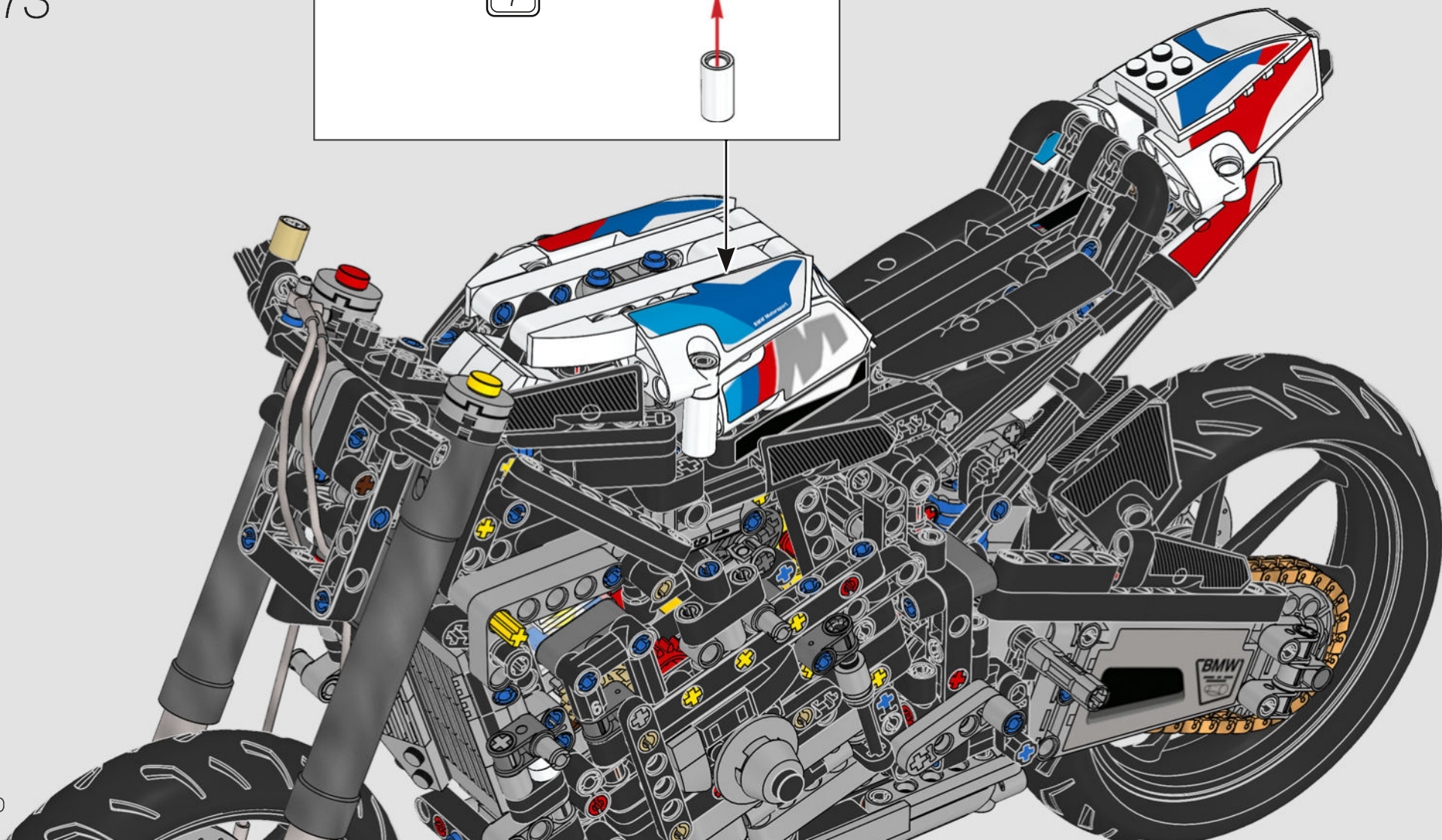
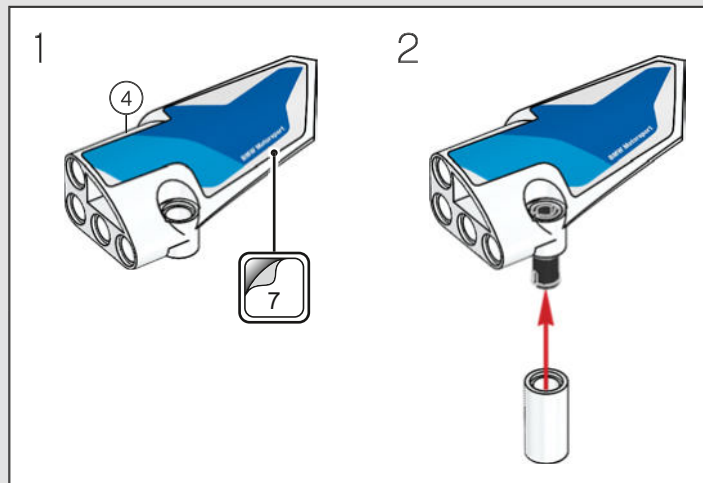

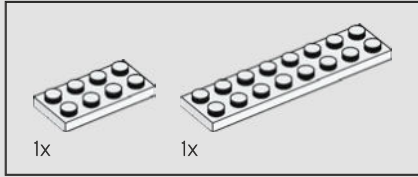
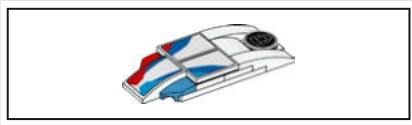

474

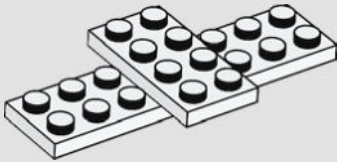

475

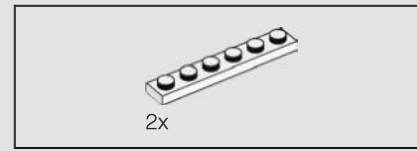
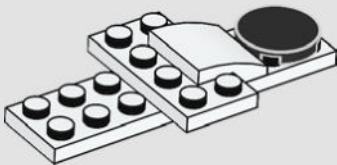

476

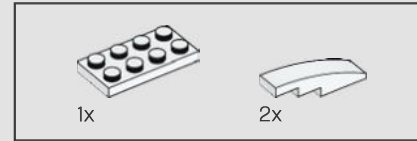
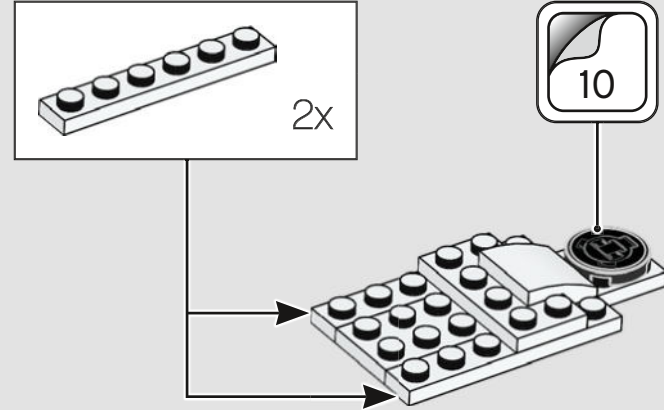
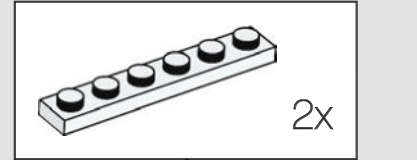

477

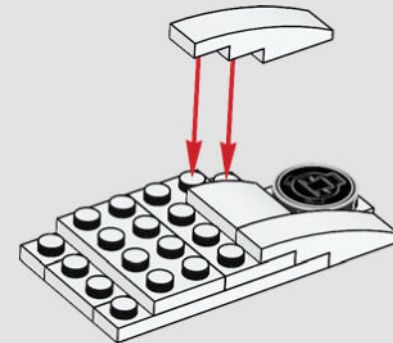

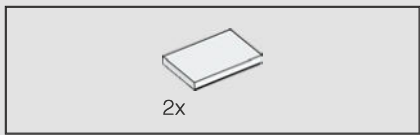

478

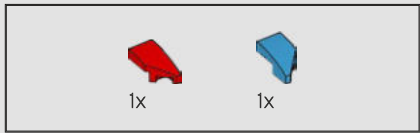
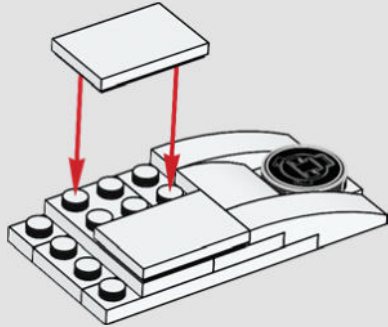

479

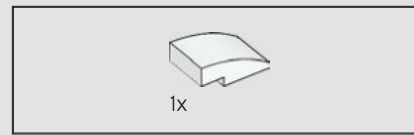
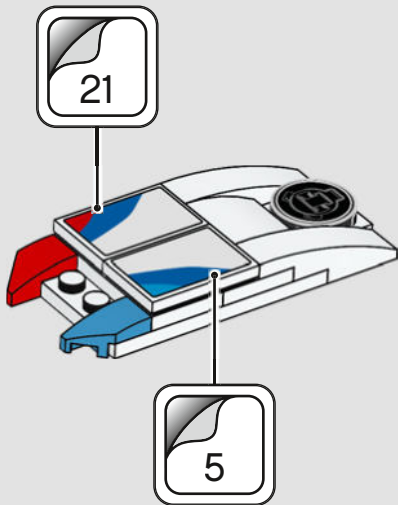

480

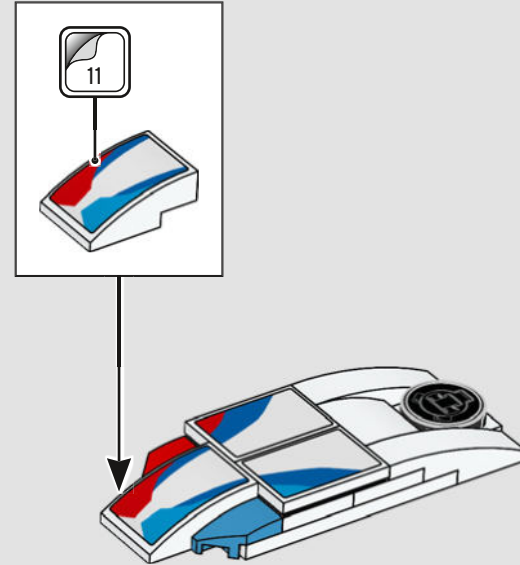

481

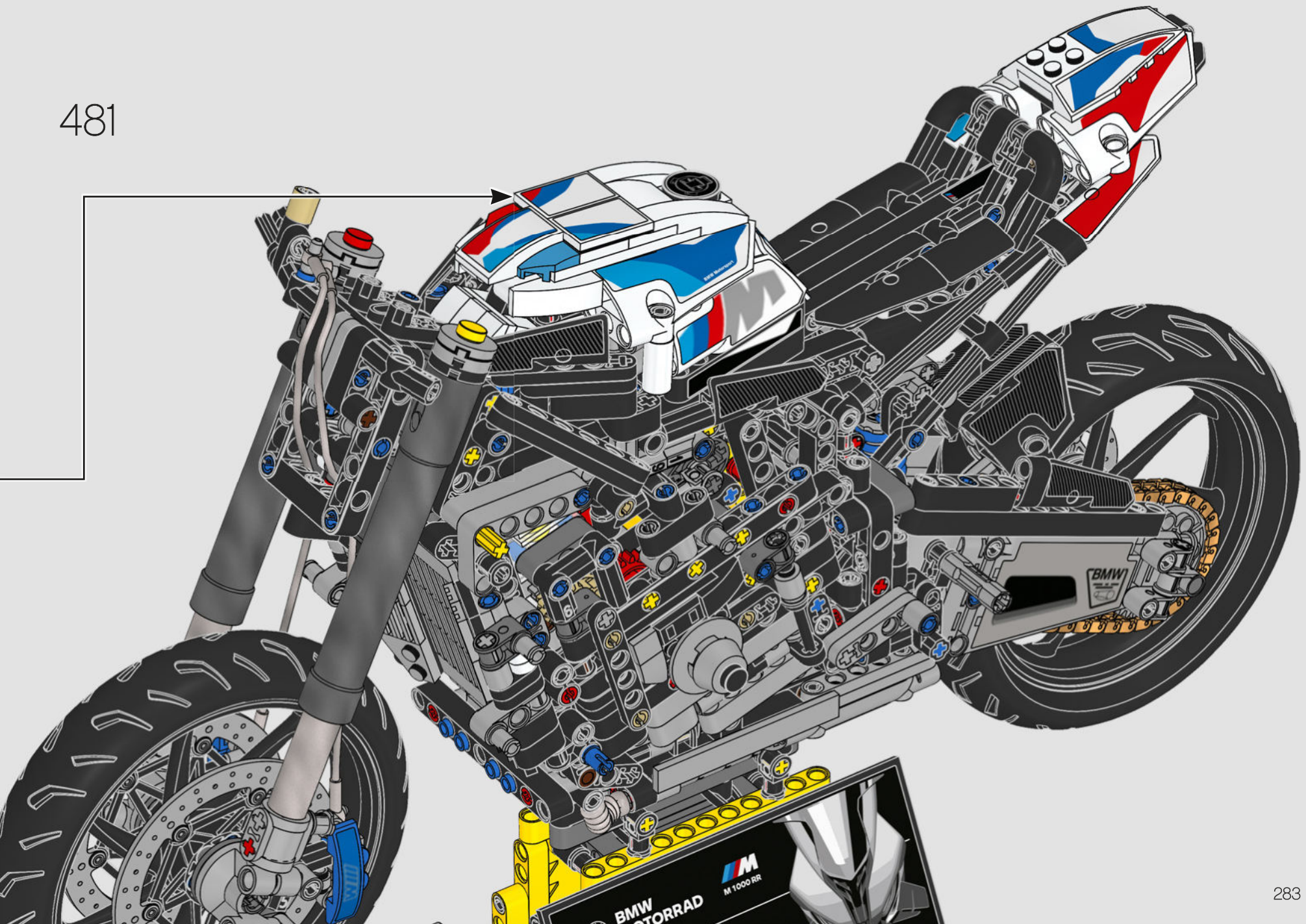

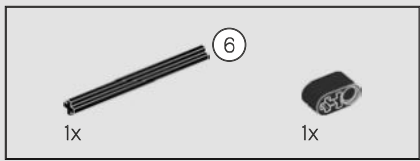

482

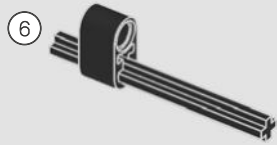

483

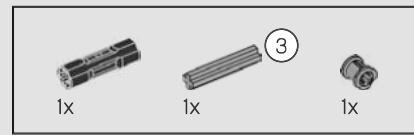
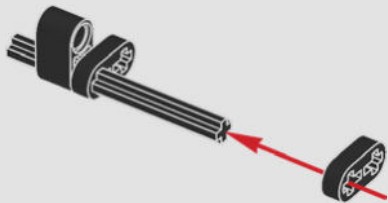

484

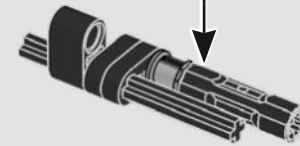
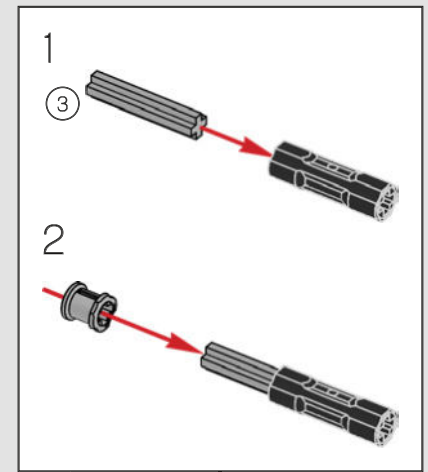

485

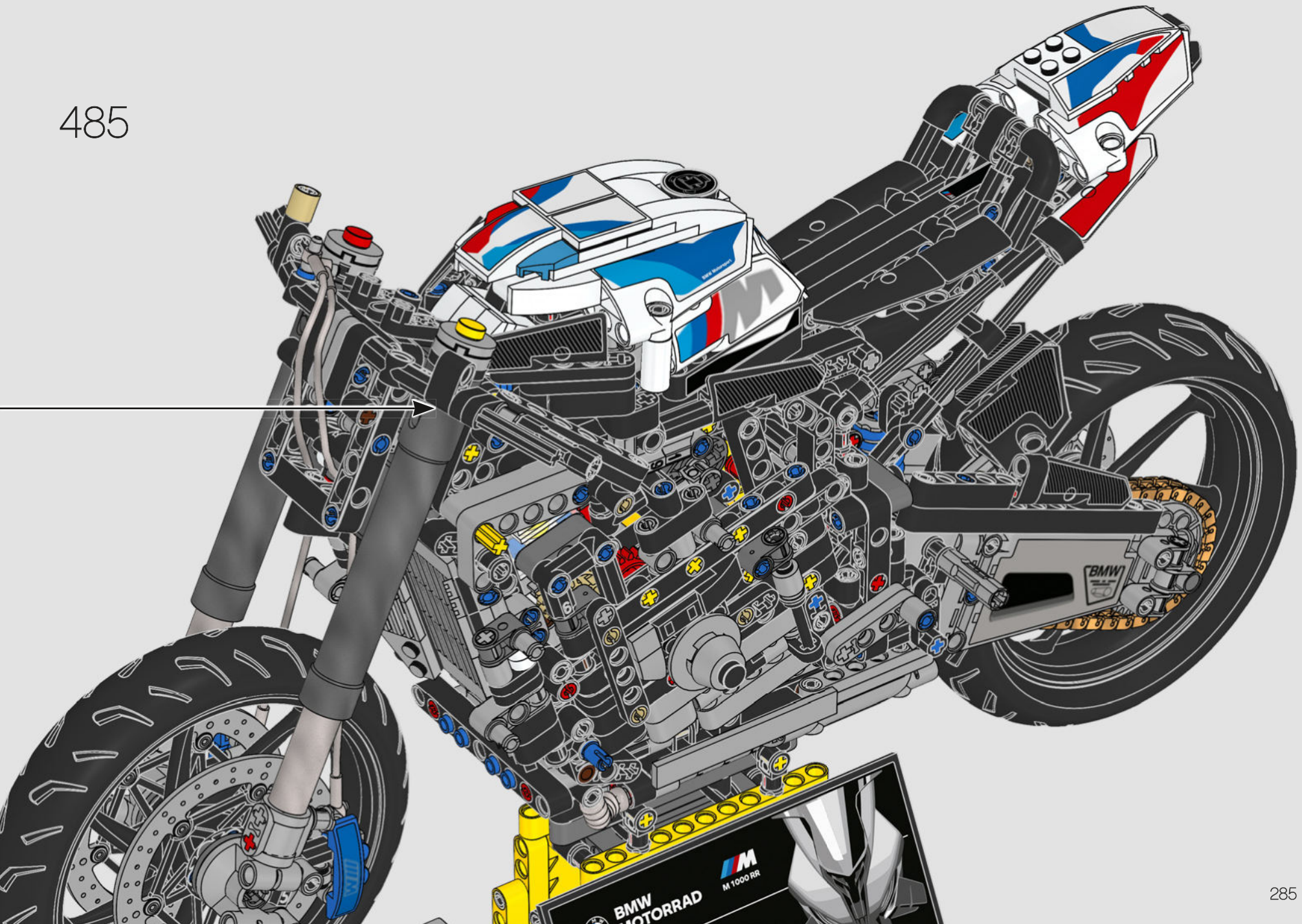

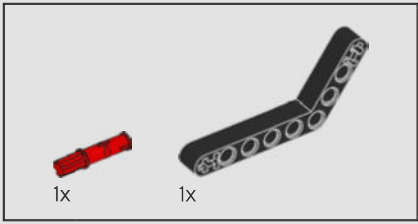

486

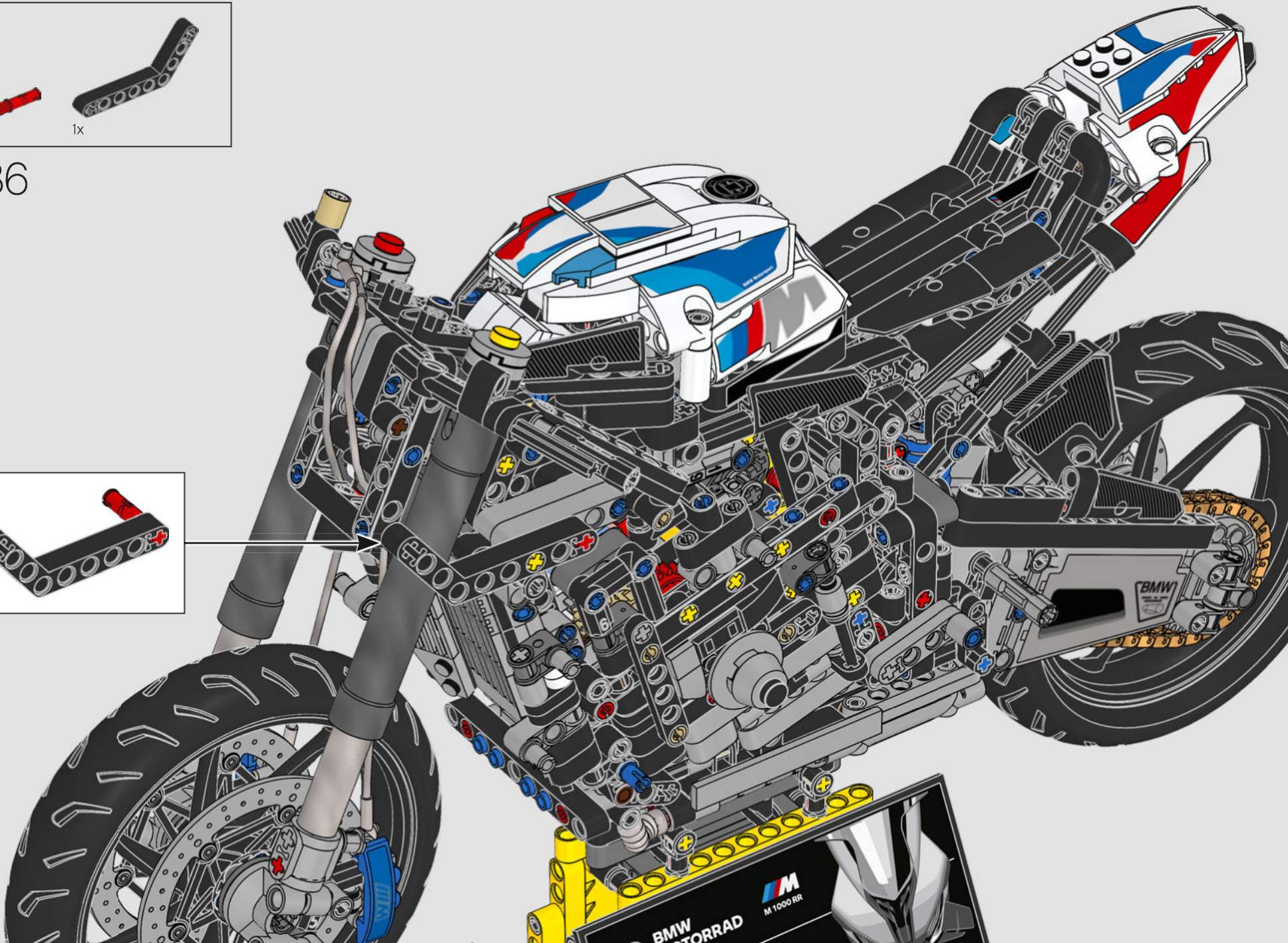
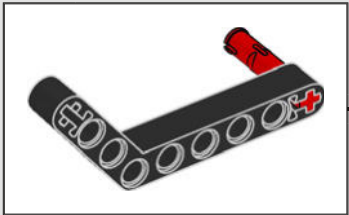

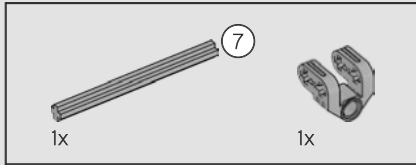
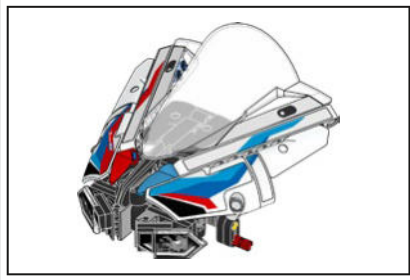

487

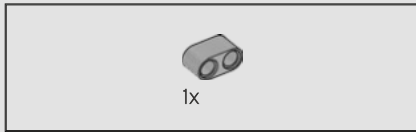
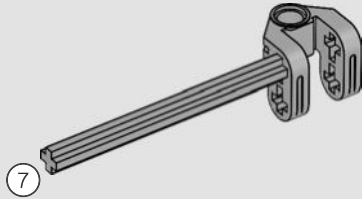

488

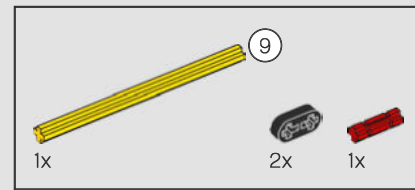
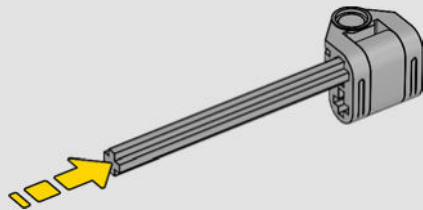

489

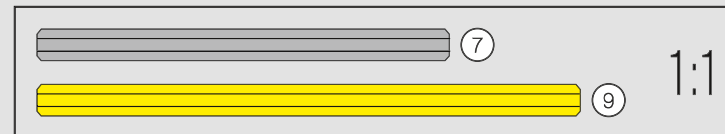
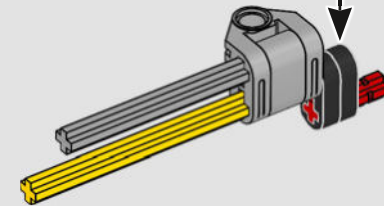
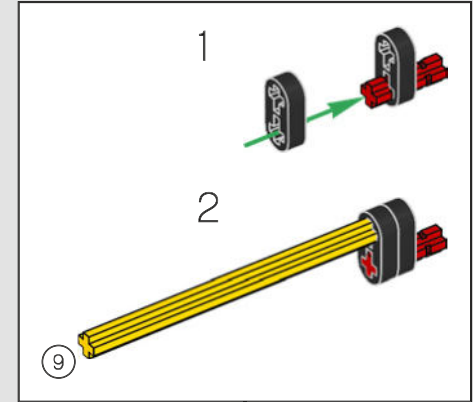

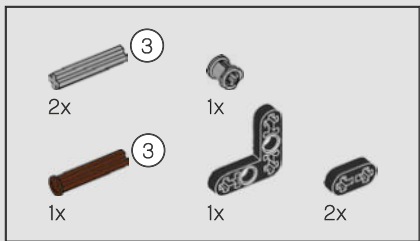

490

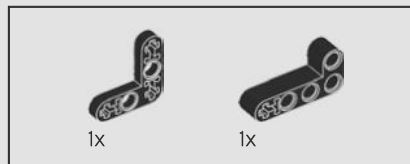
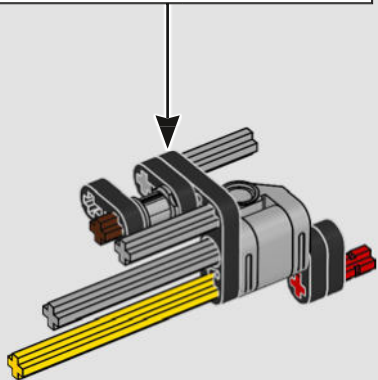
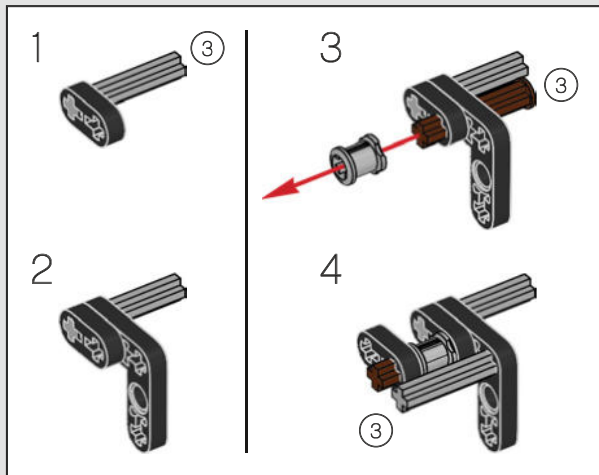

491

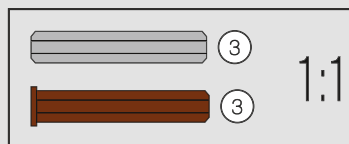
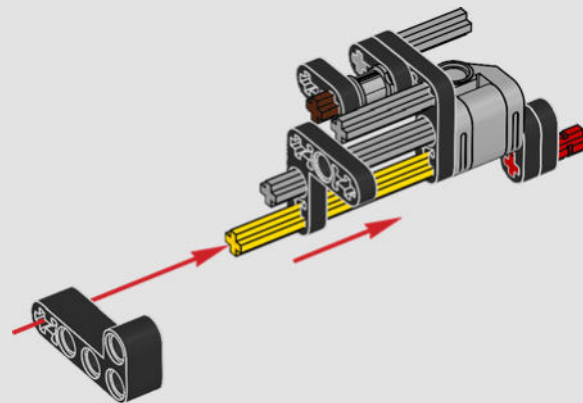

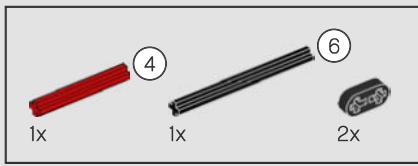

492

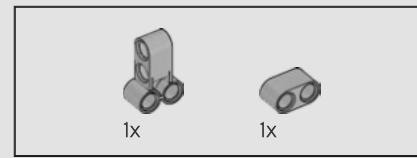
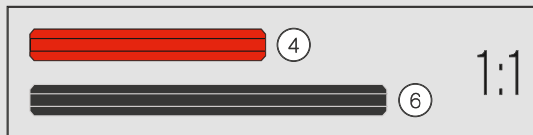
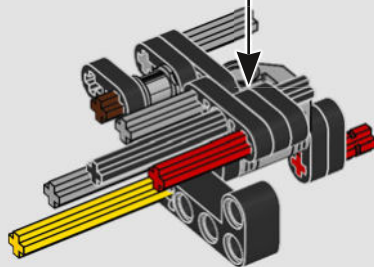
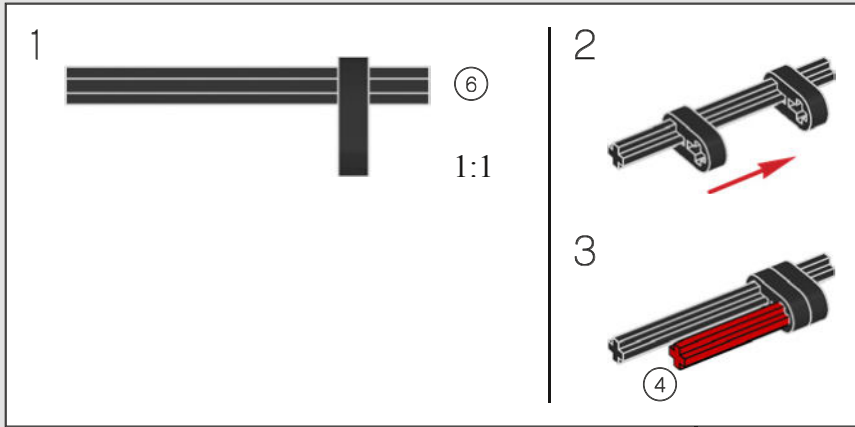

493

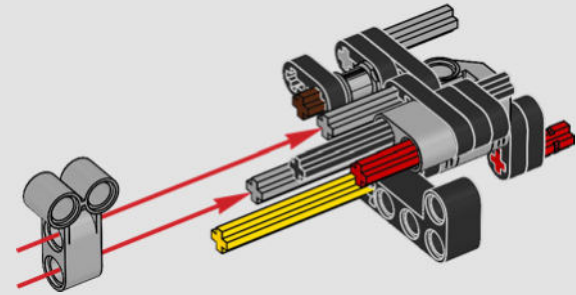

494

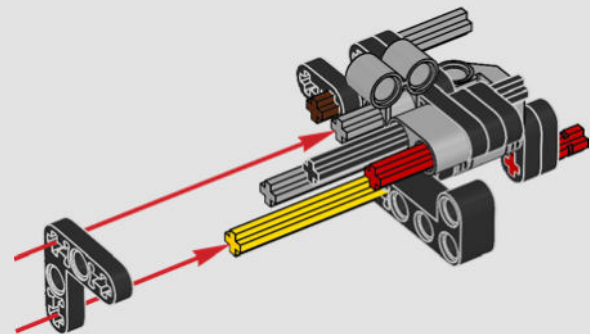

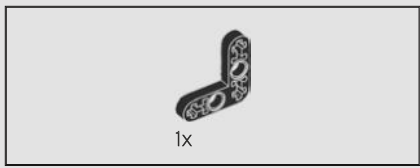

495

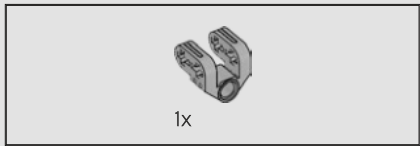
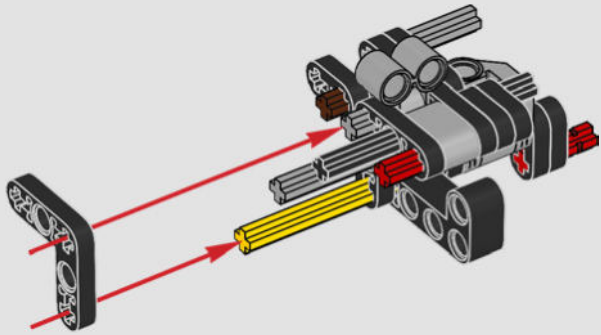

496

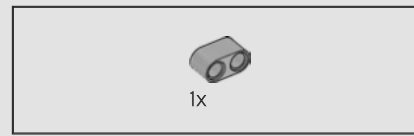
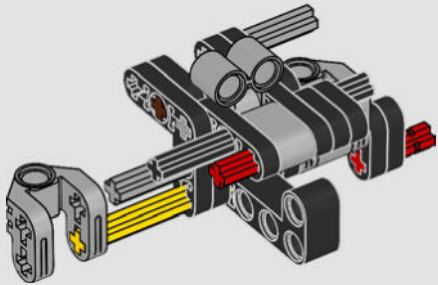

497

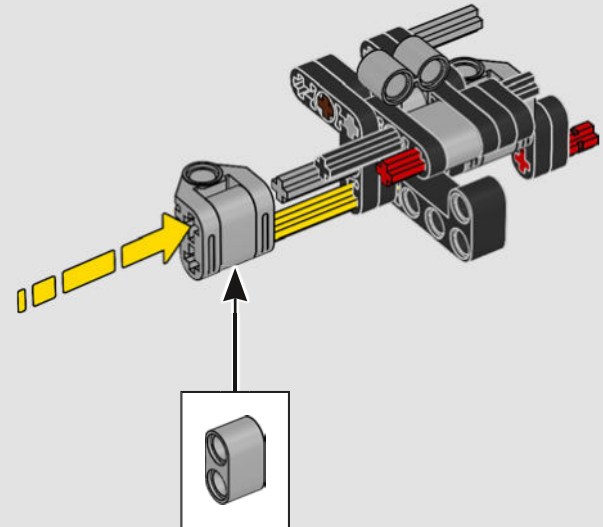

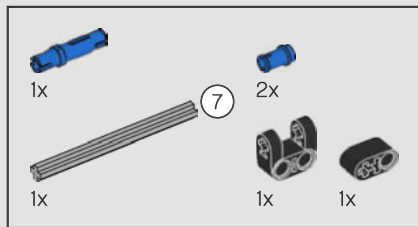

498

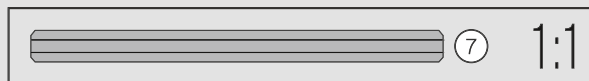
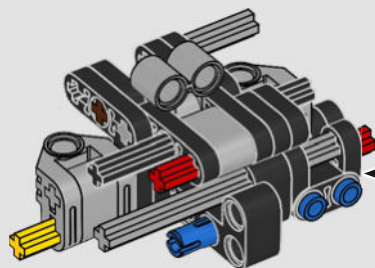
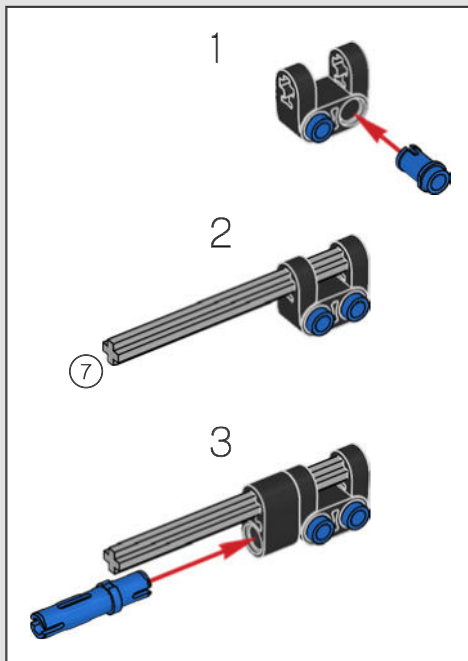

499

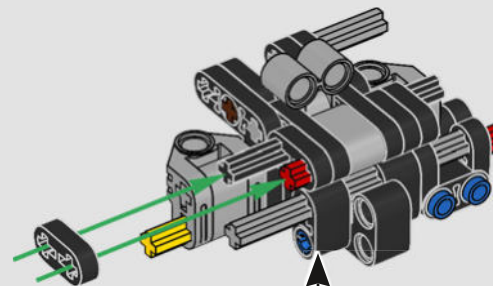

500

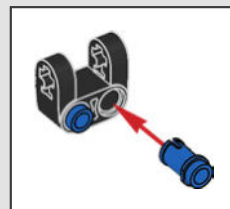
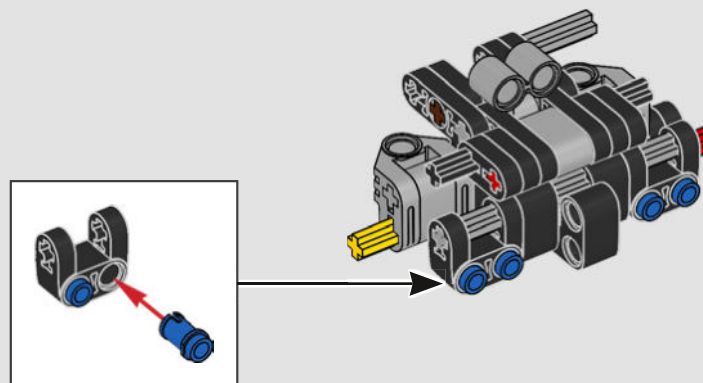



501

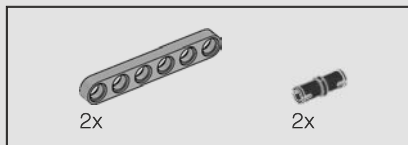
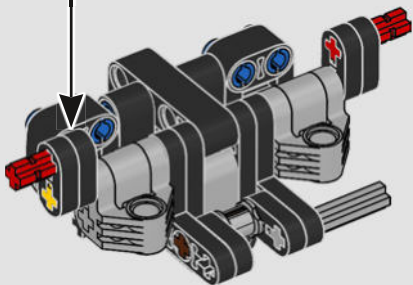
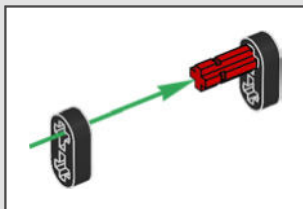

502

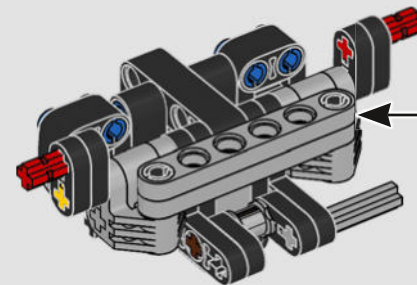
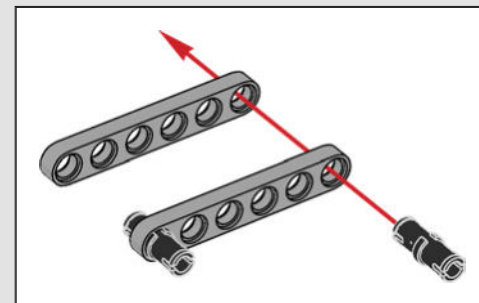

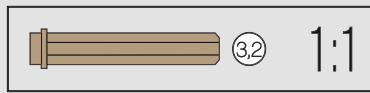

503

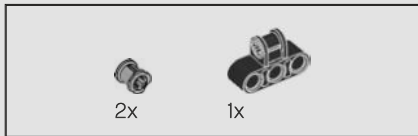
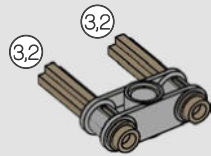

504

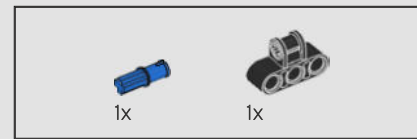
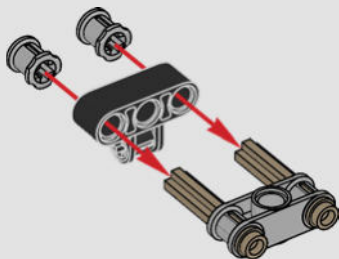

505

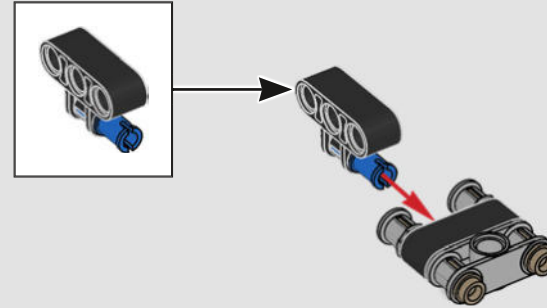

506

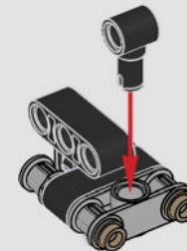

507

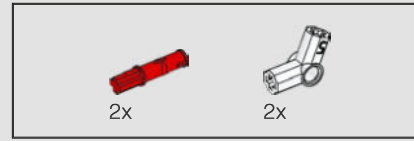
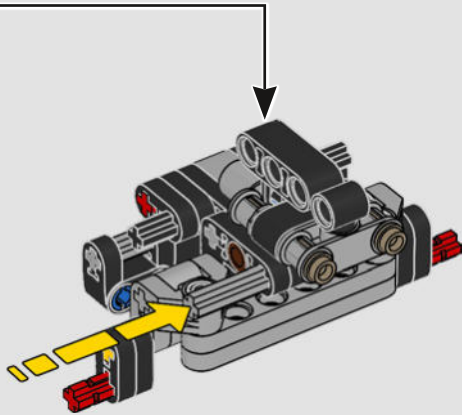

508

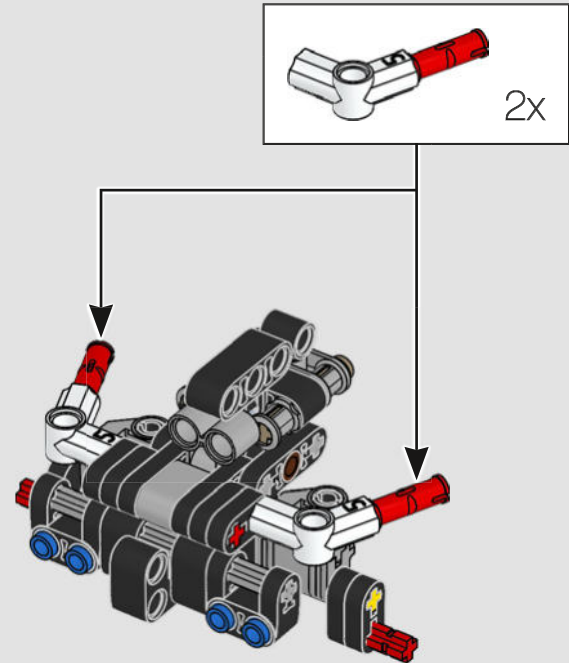

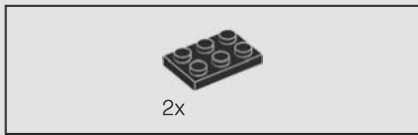

509

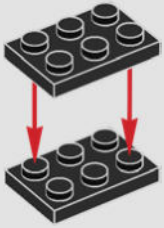

510

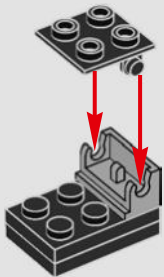

511

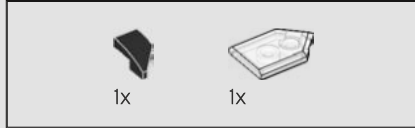

512

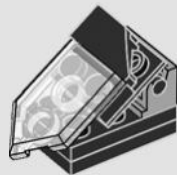

513

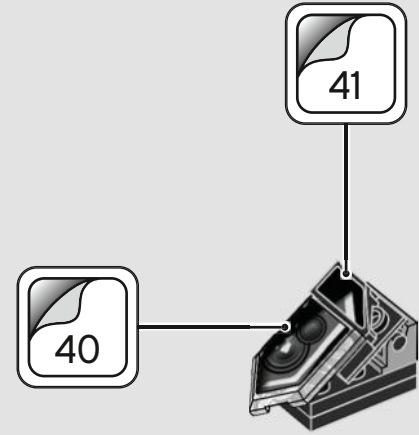

514

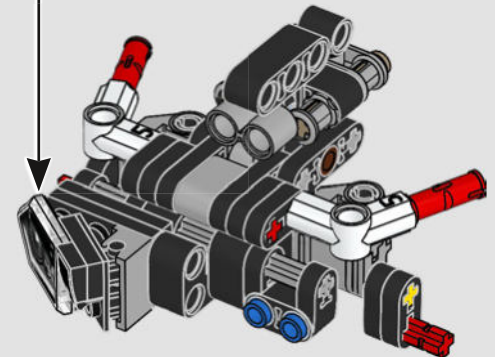

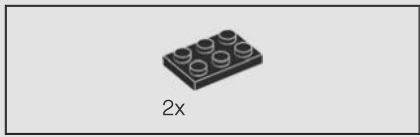

515

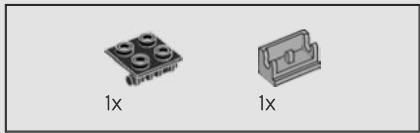
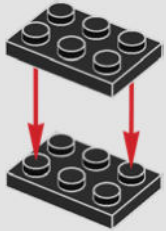

516

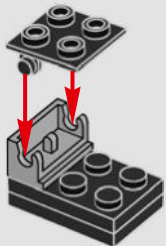

517

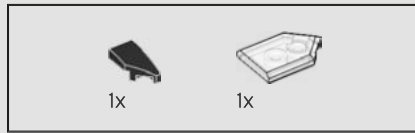
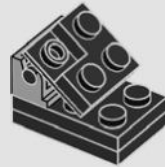

518

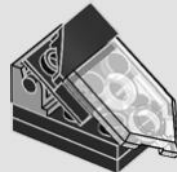

519

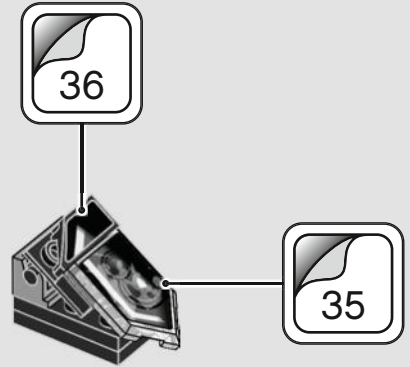

520

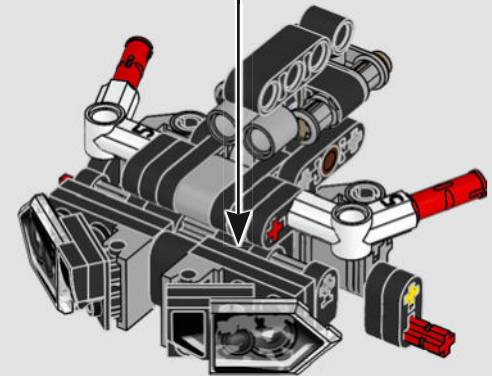

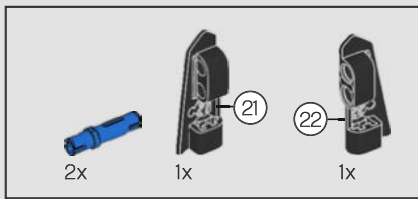

521

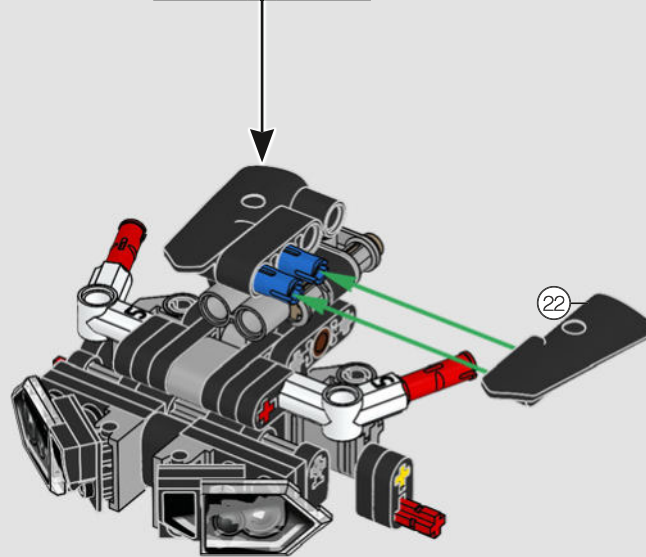
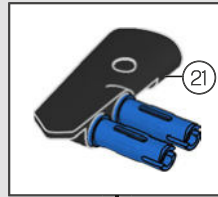

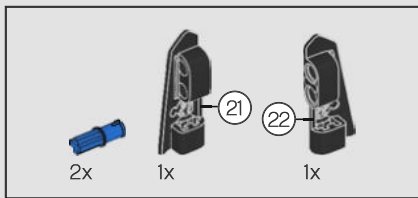

522

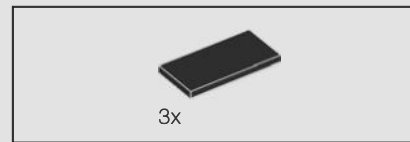
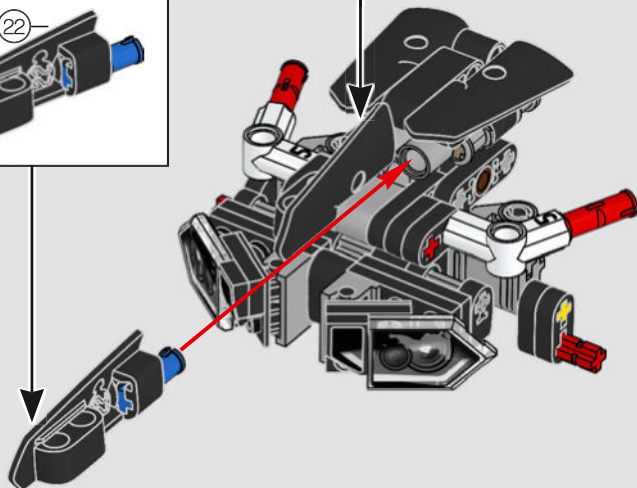
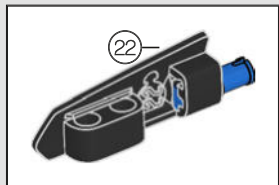
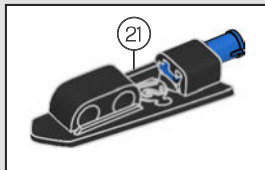

523

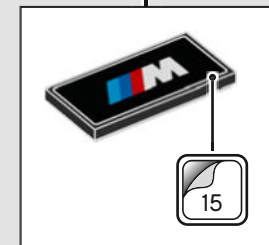
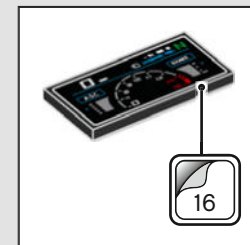
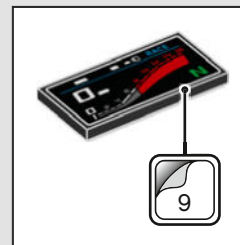
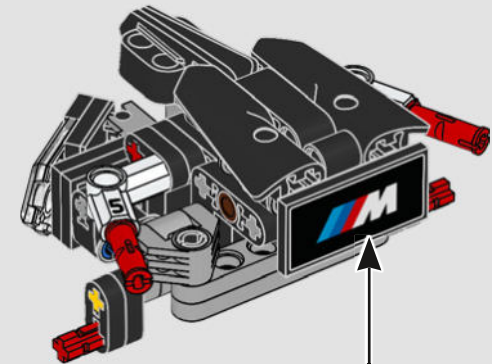
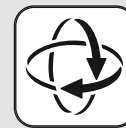

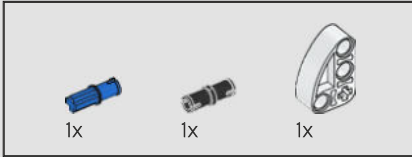
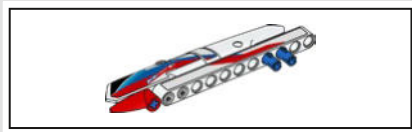

524

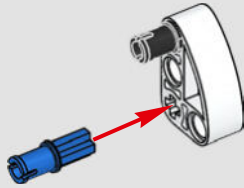

525

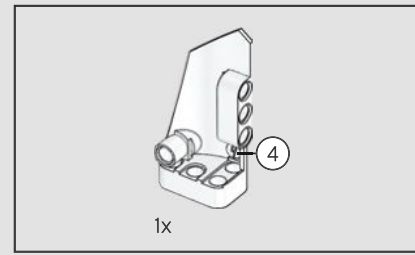
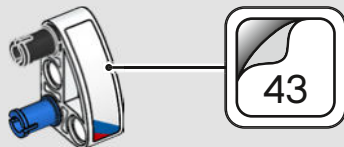

526

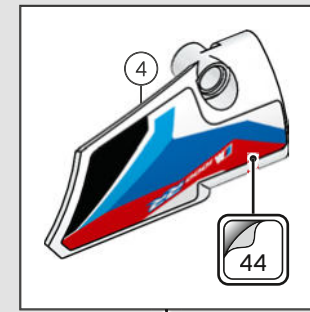

527

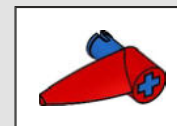
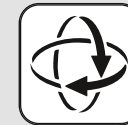

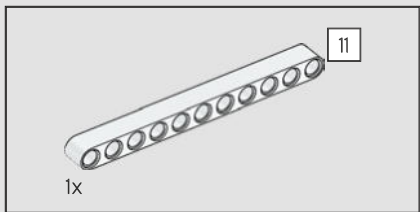

528

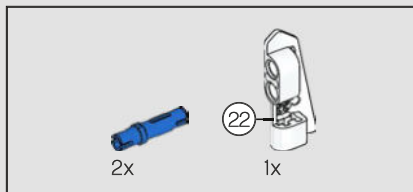
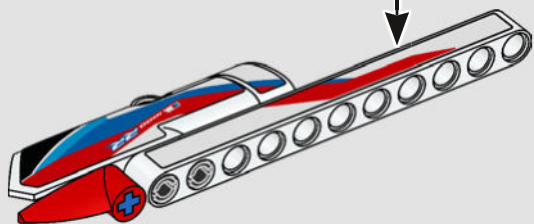
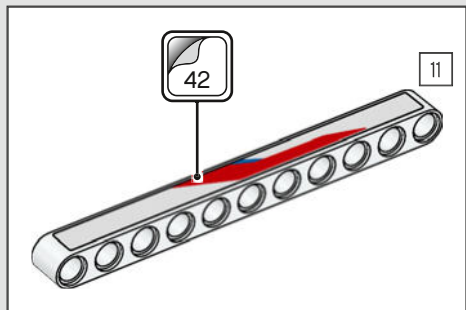

529

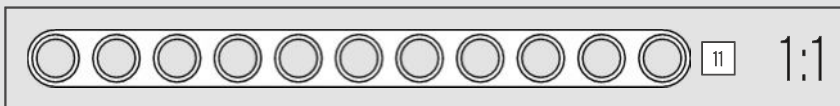
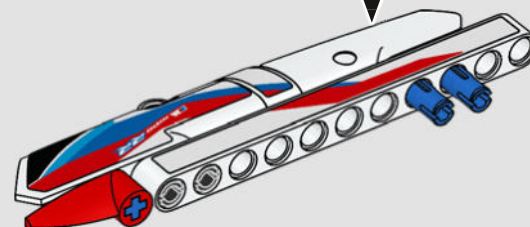
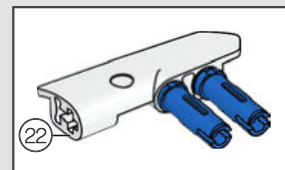

530

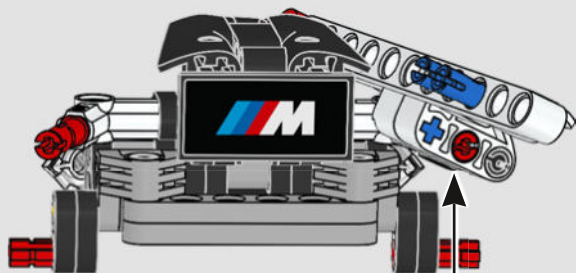

531

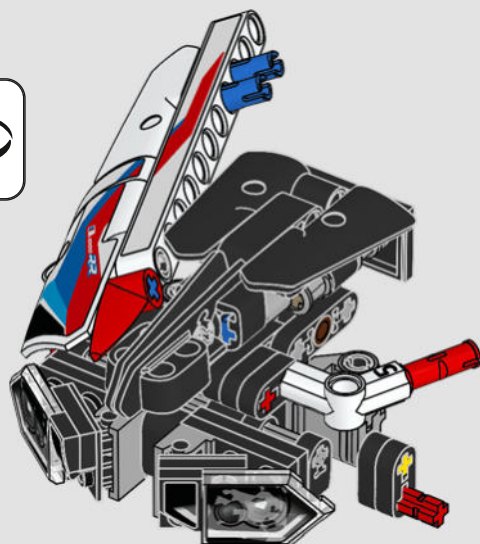

532

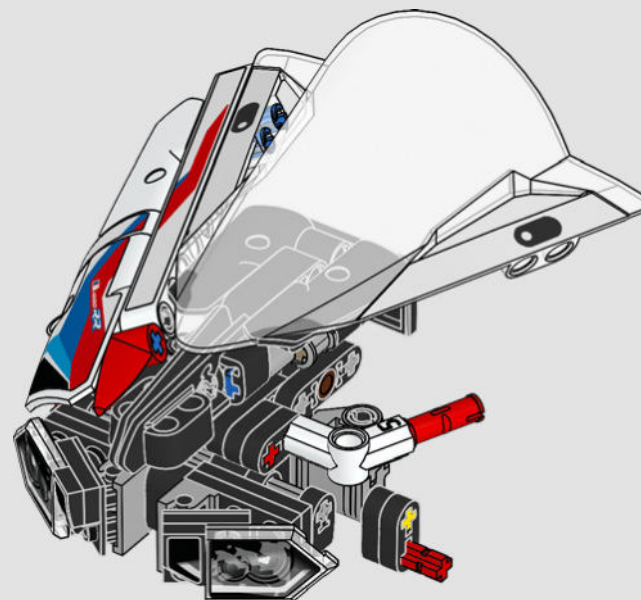
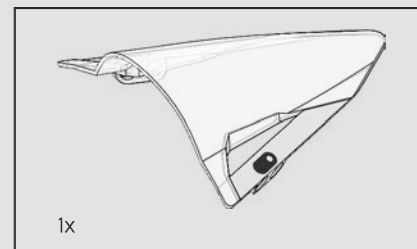

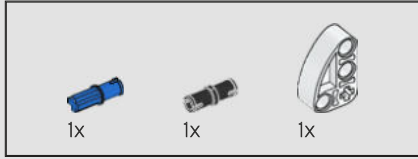
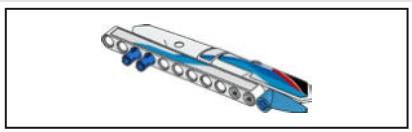

533

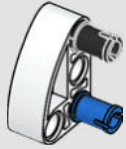

534

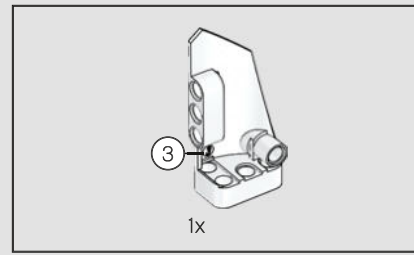
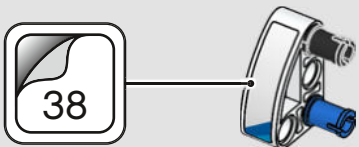

535

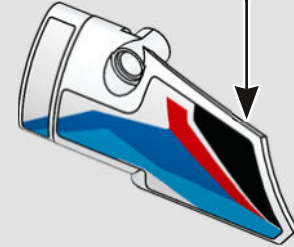
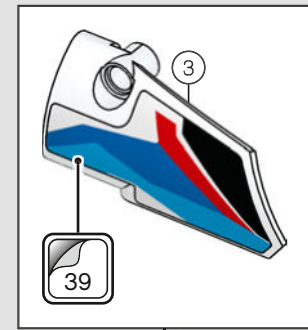

536

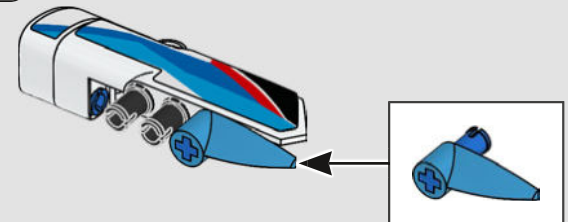

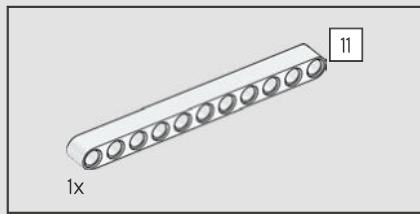

537

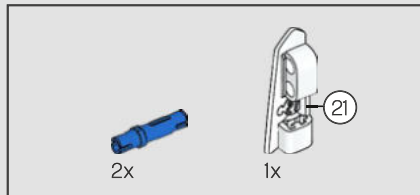
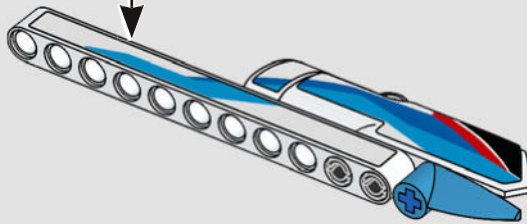
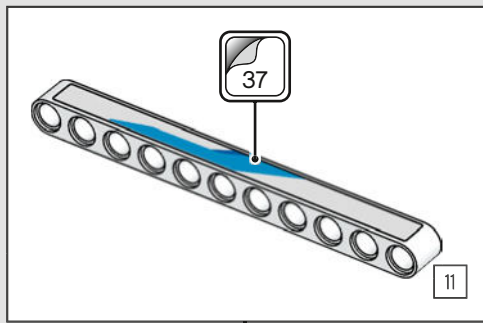

538

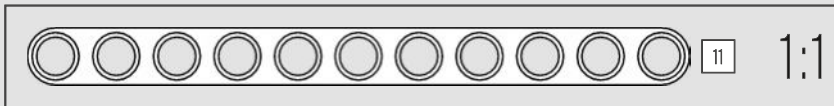
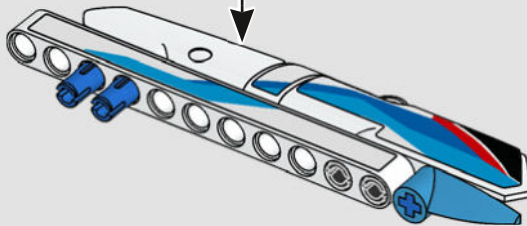
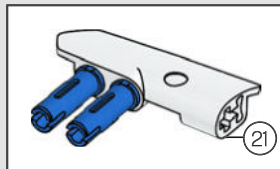

539

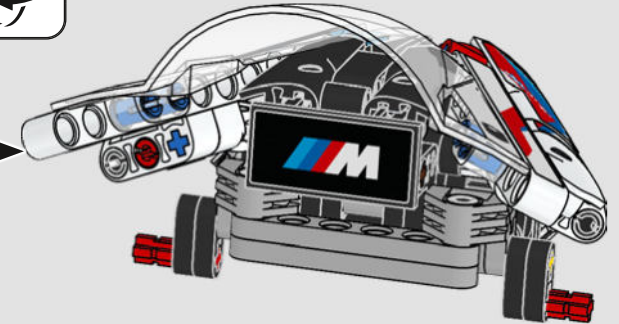

540

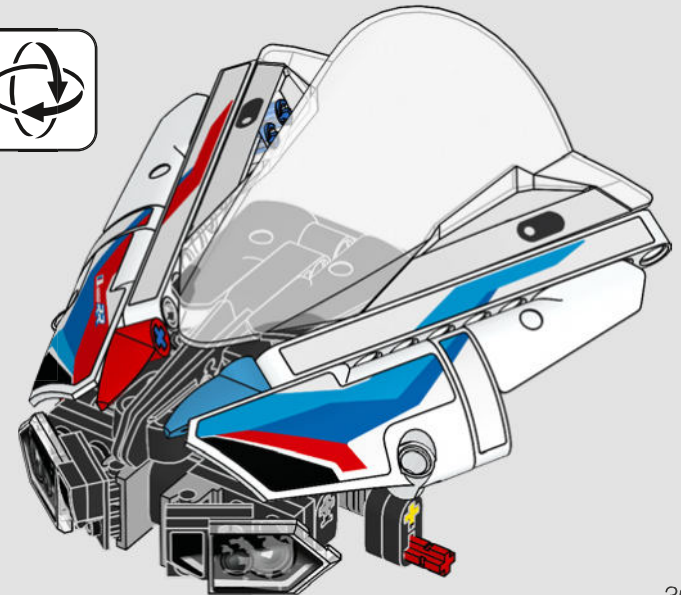

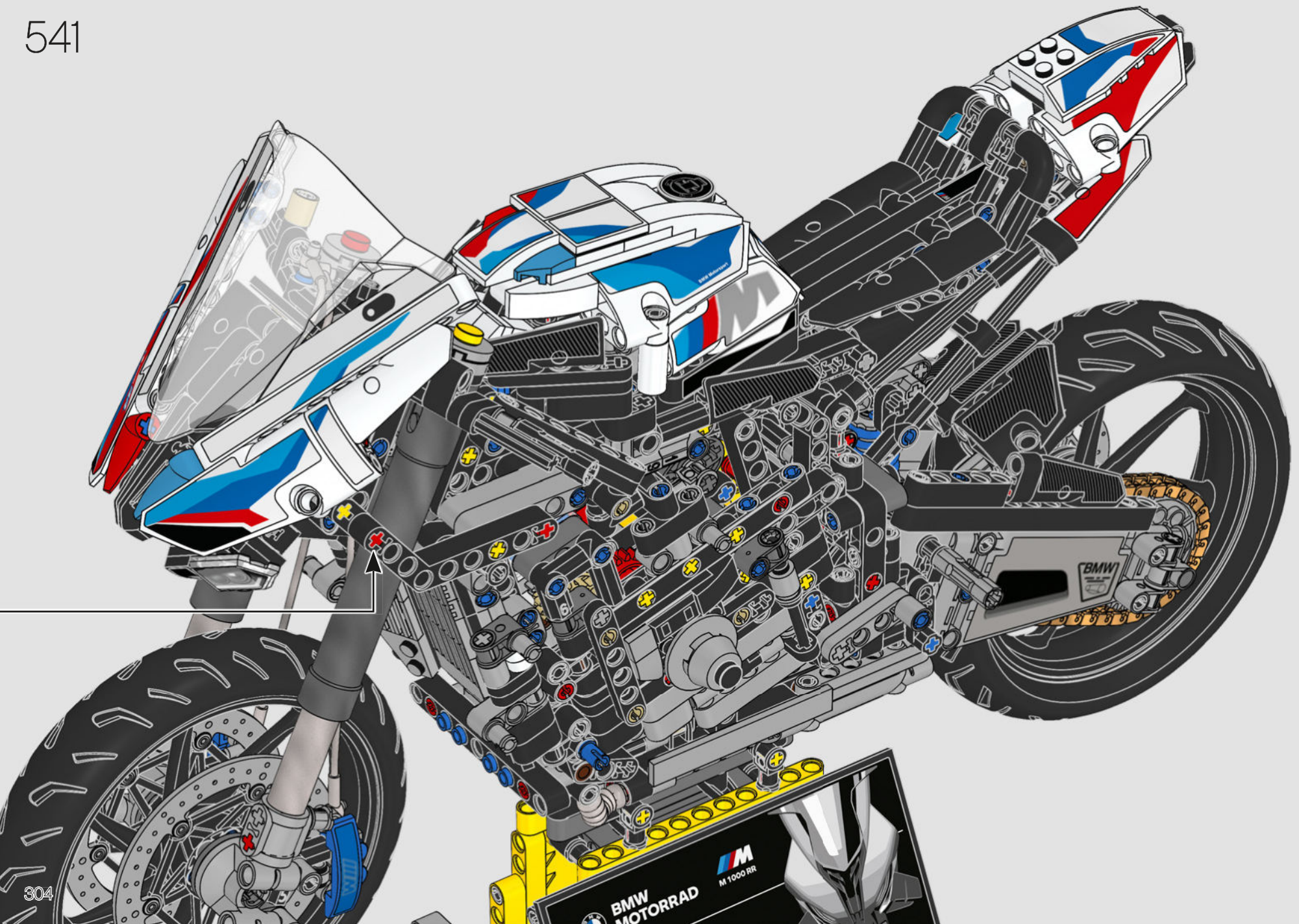

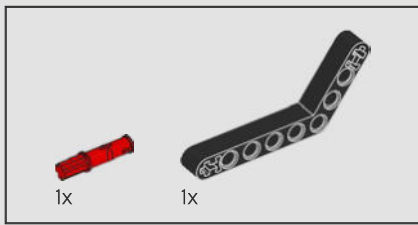

542

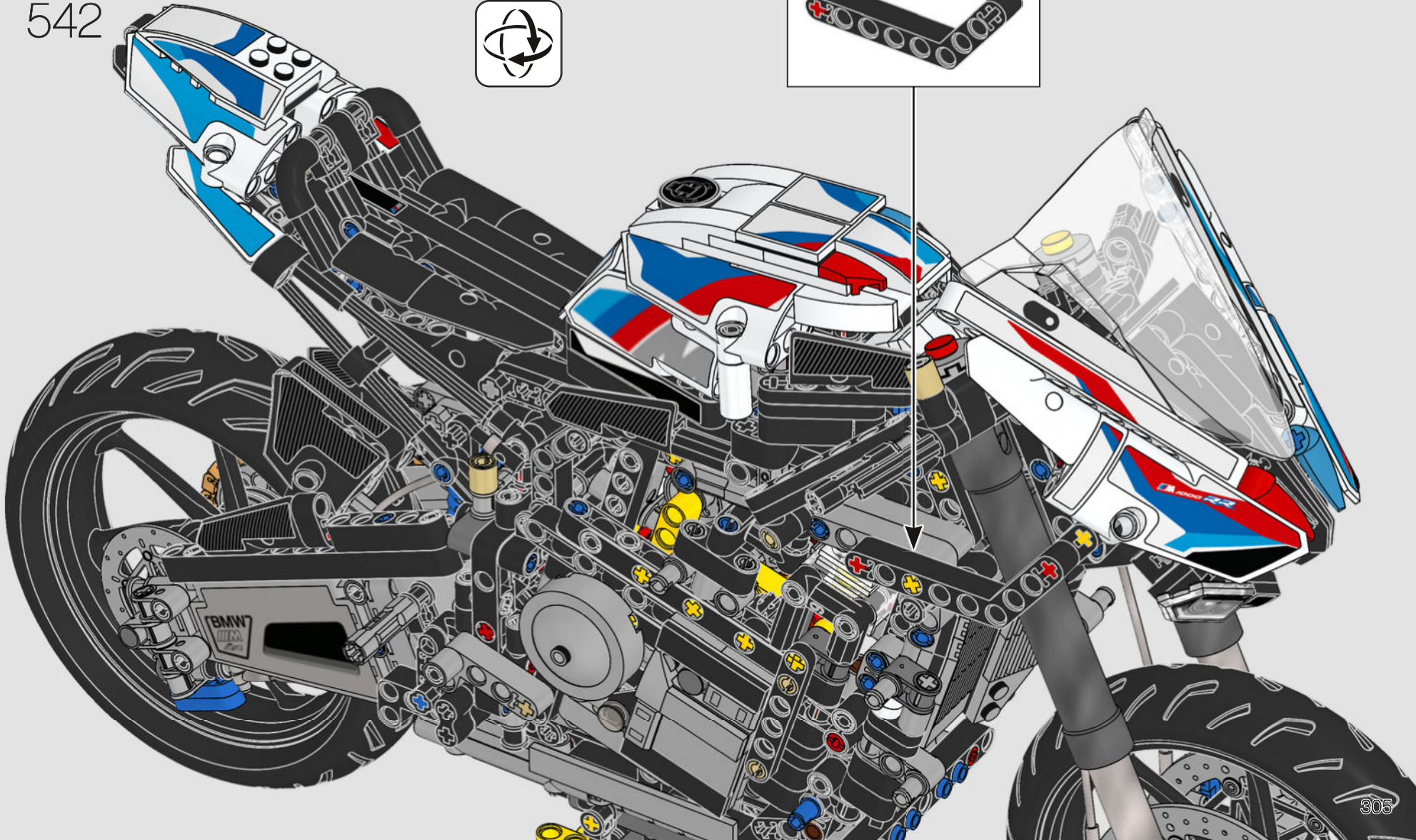
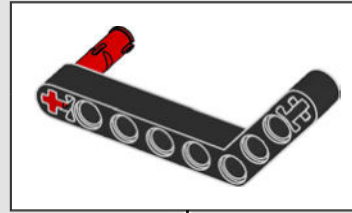

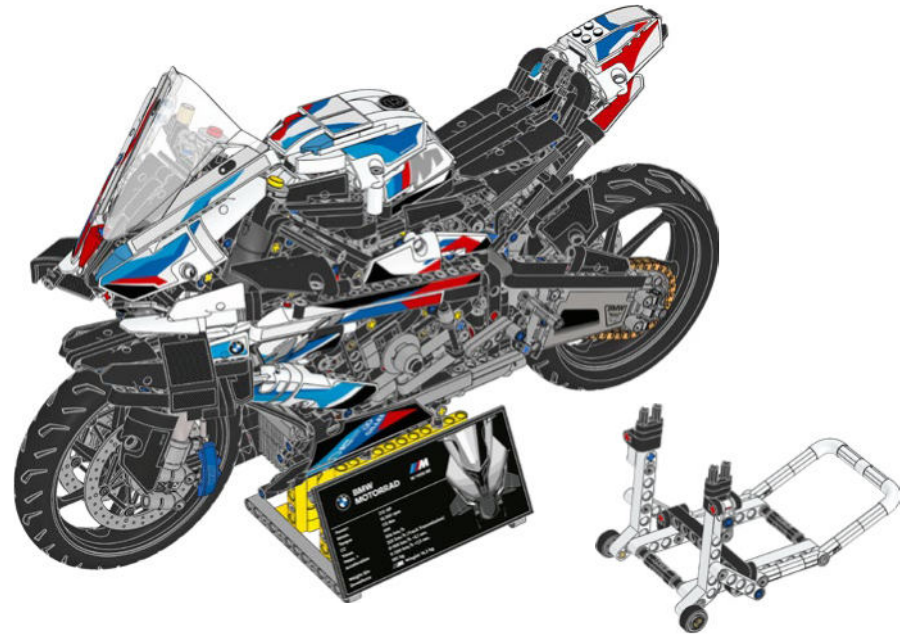
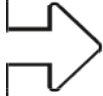

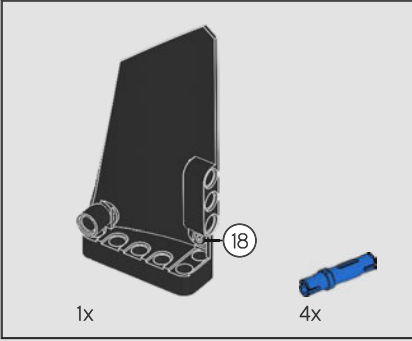
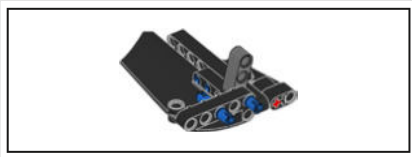

543

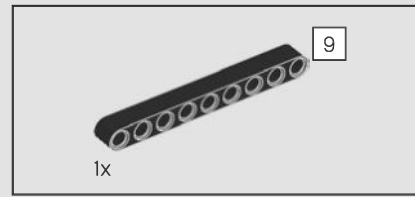
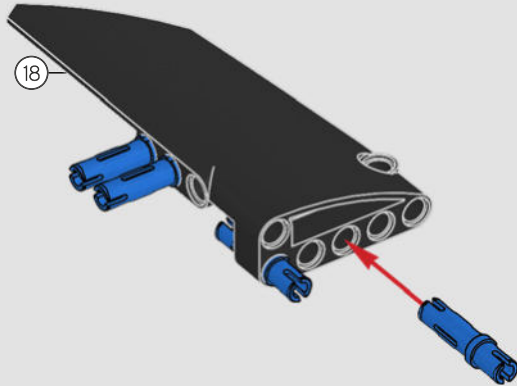

544

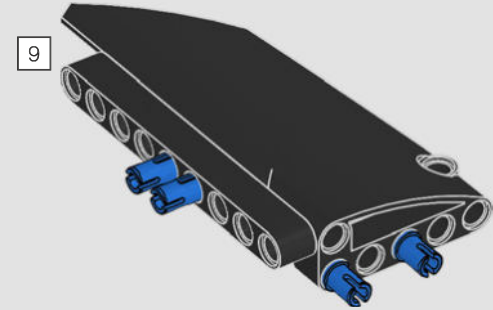

545

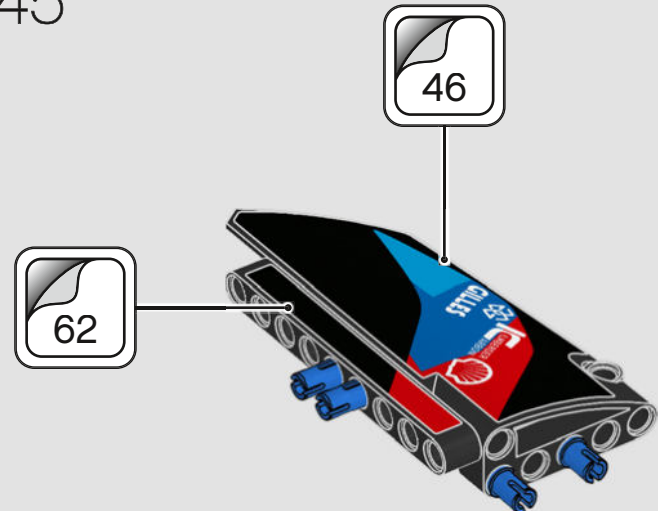

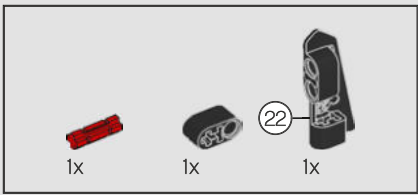

546

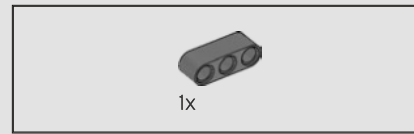
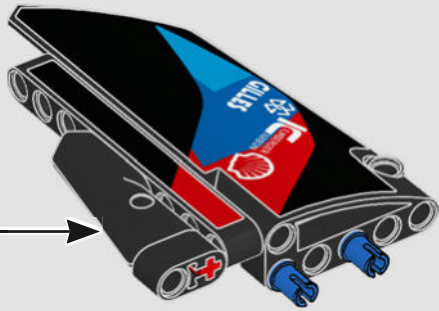
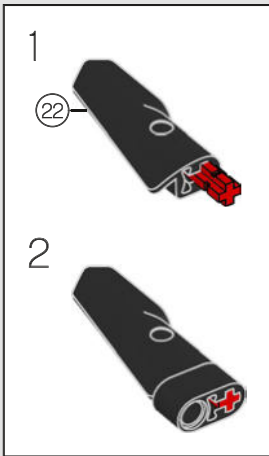

547

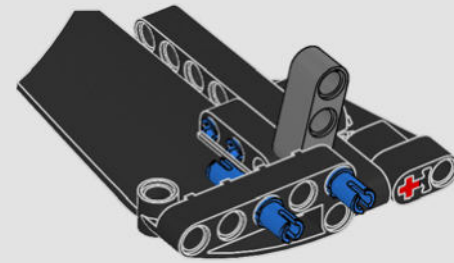

548

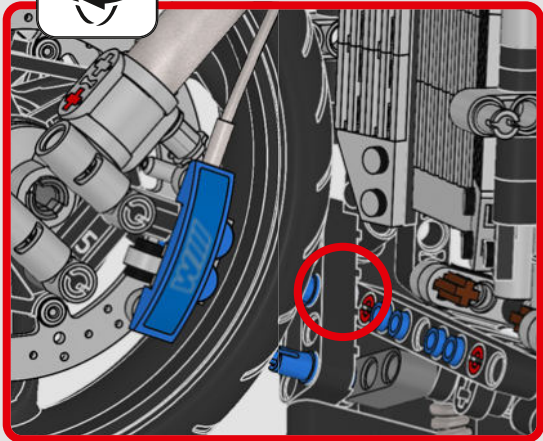
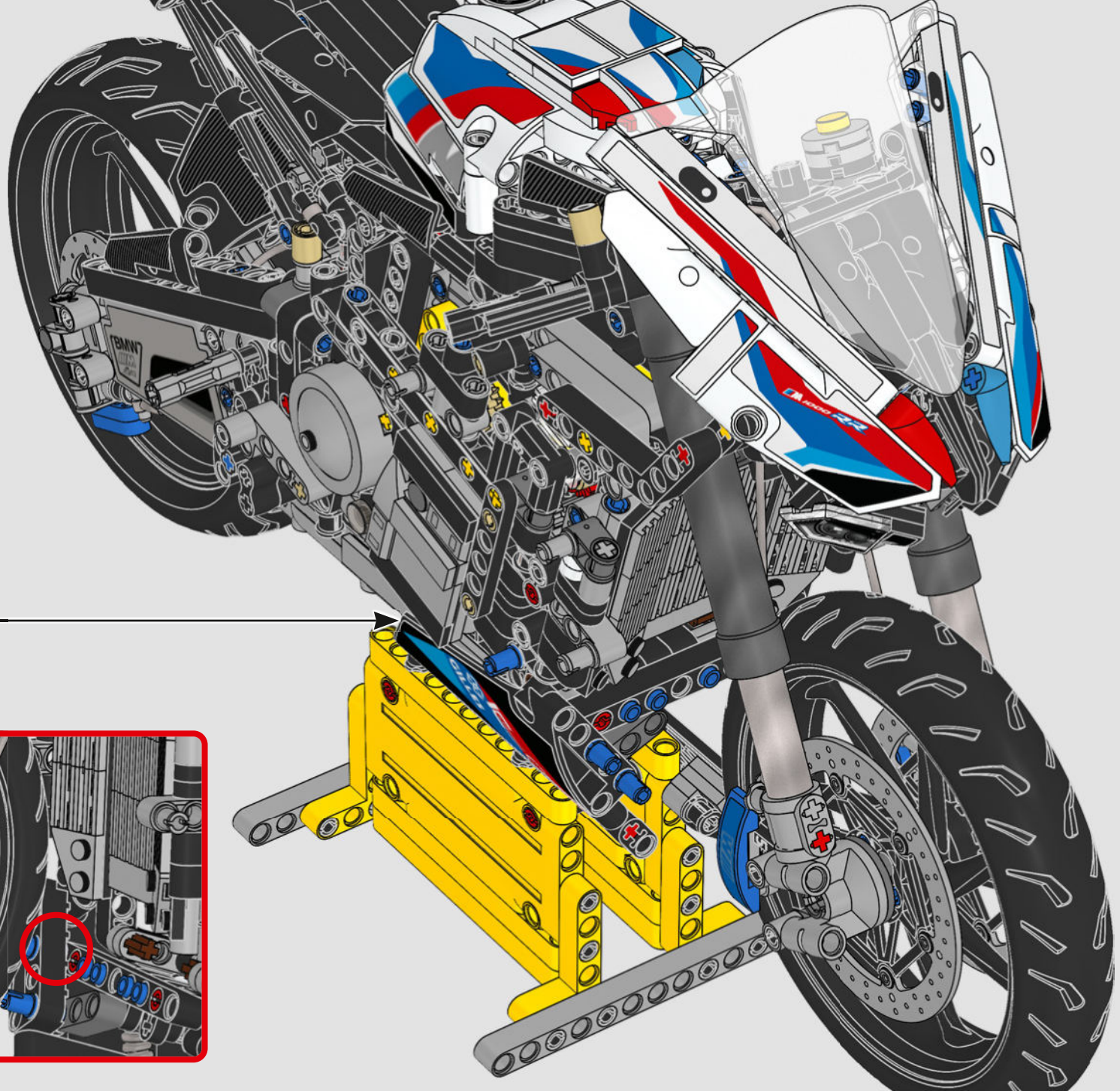

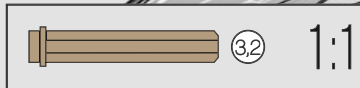
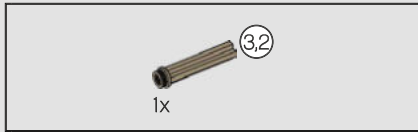

549

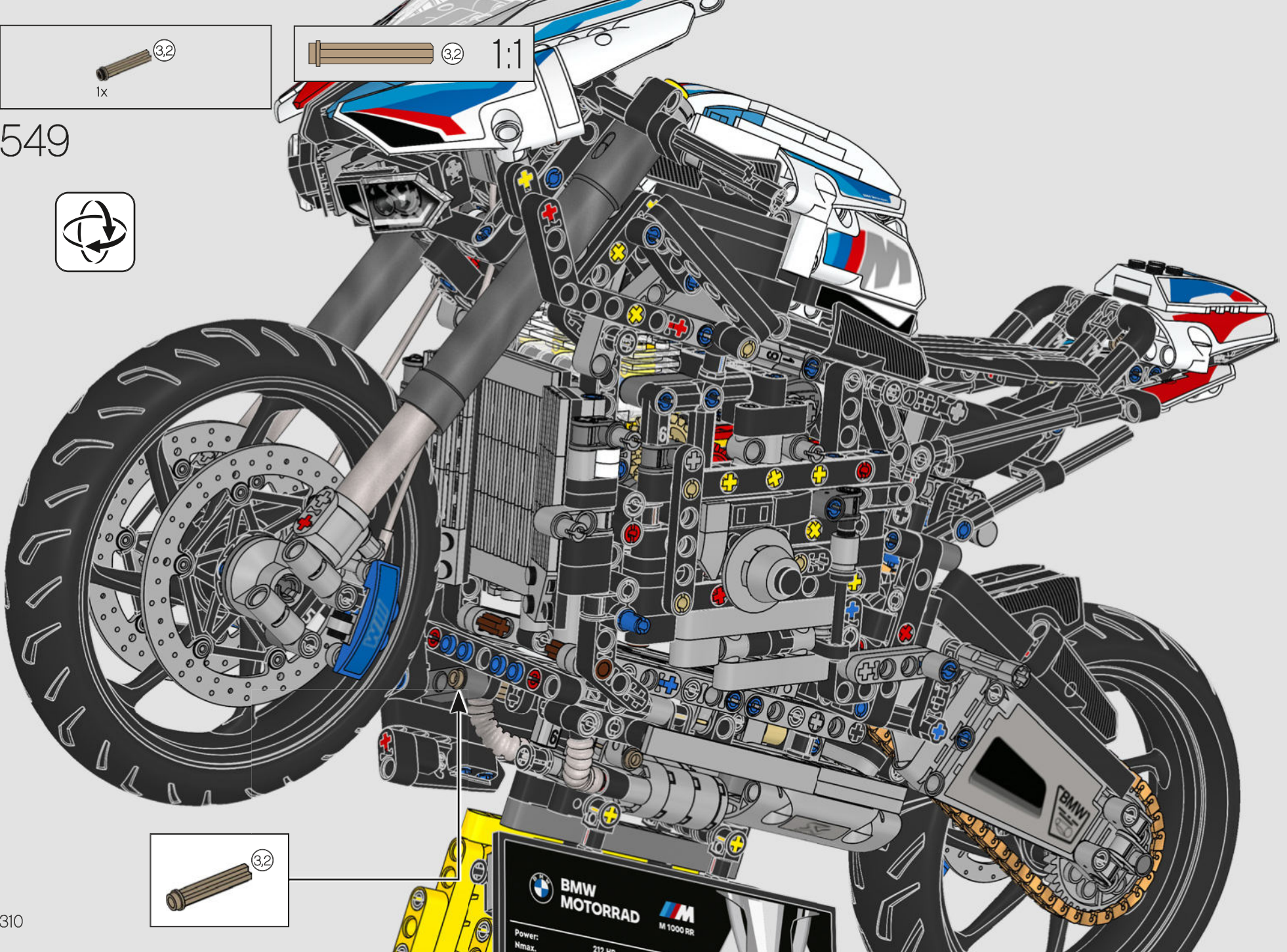
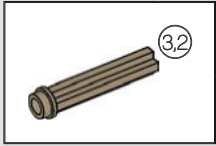

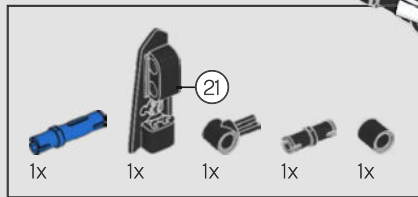

550

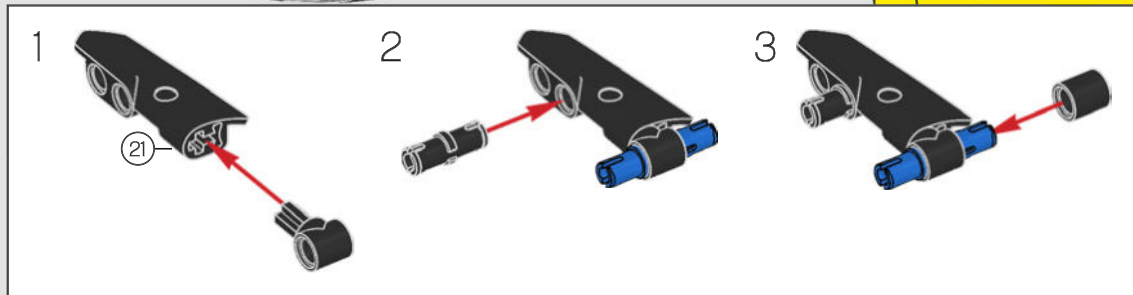
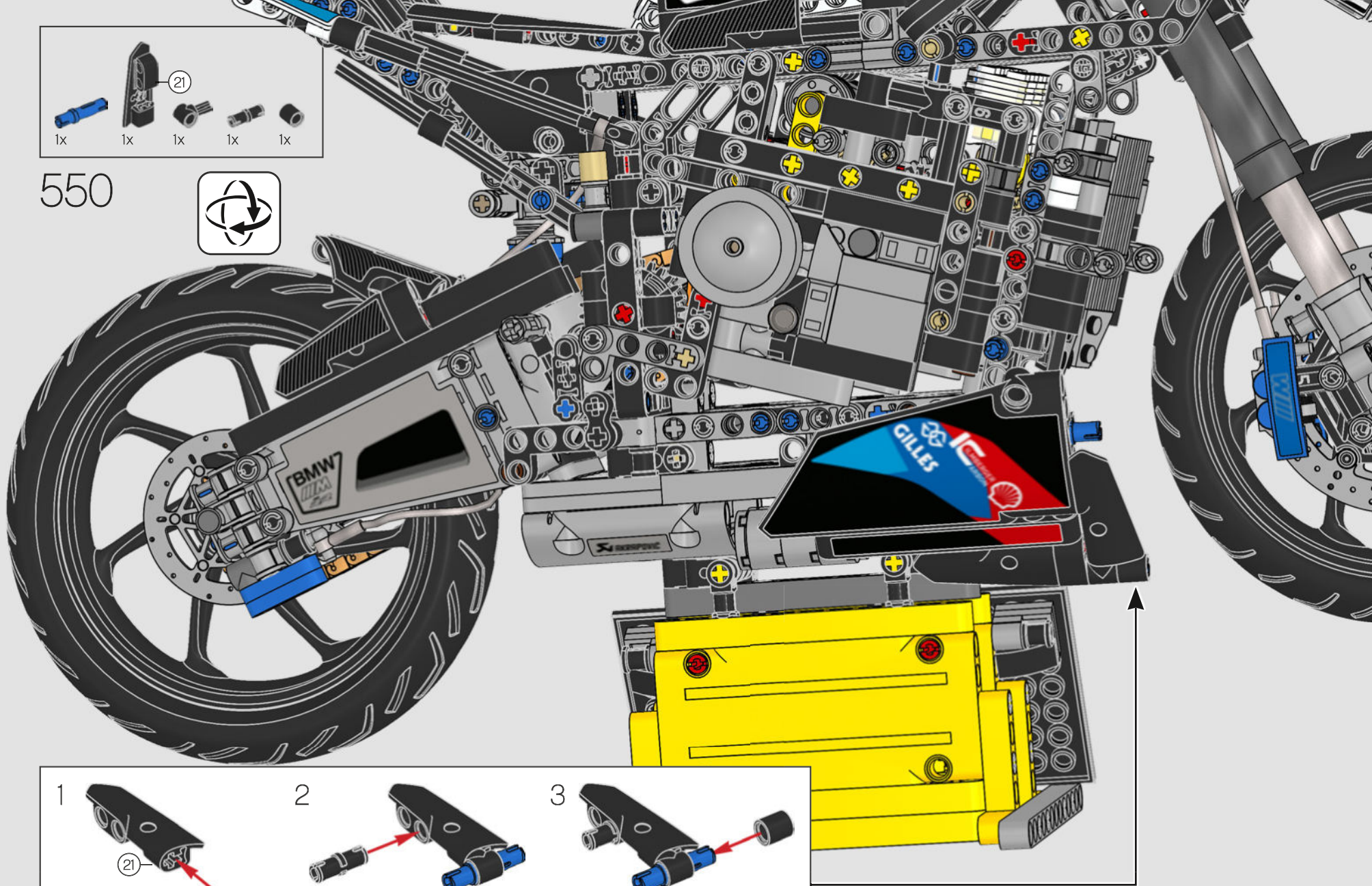

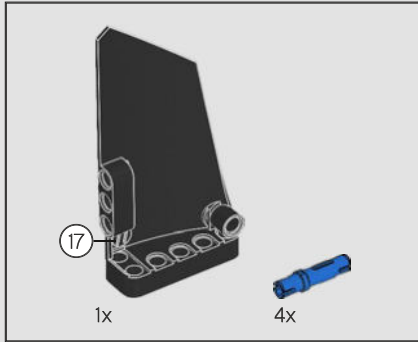
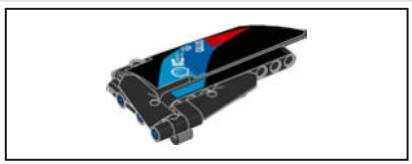

551

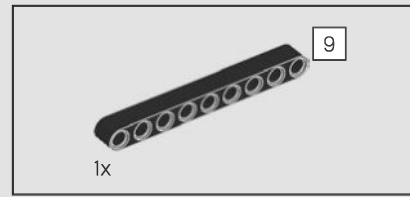
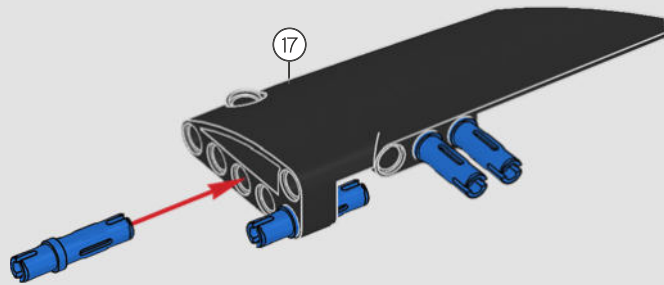

552

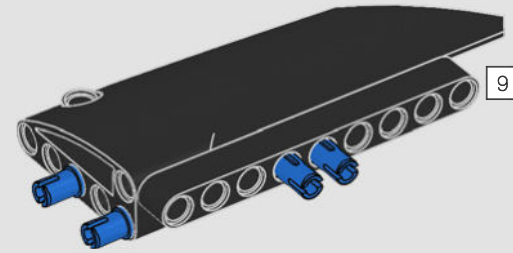

553

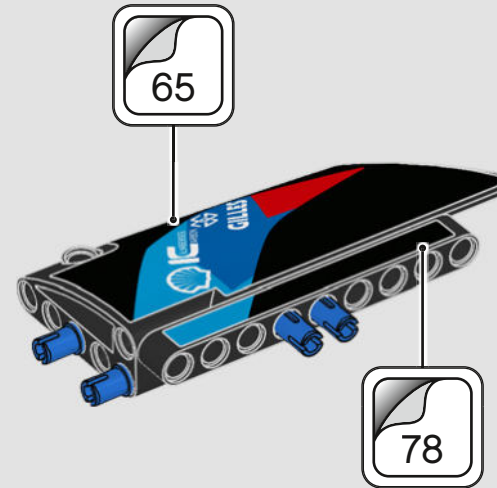

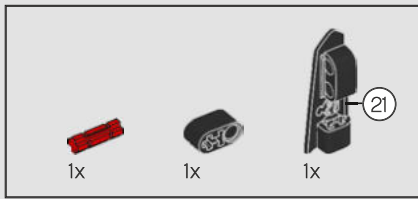

554

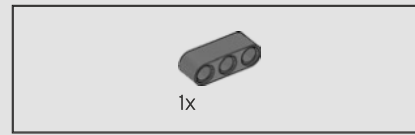
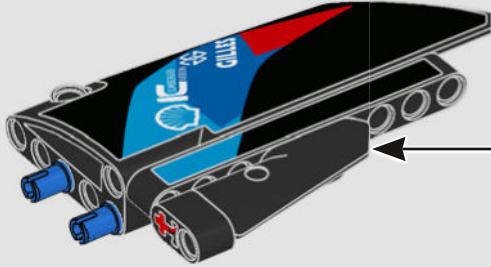
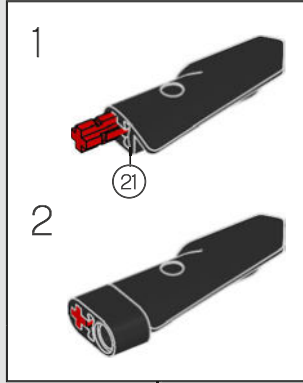

555

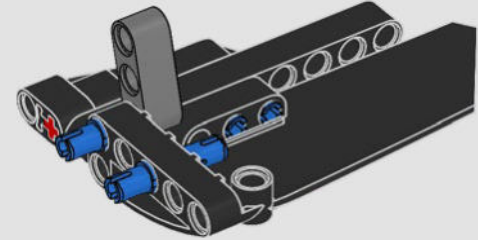
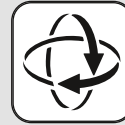

556

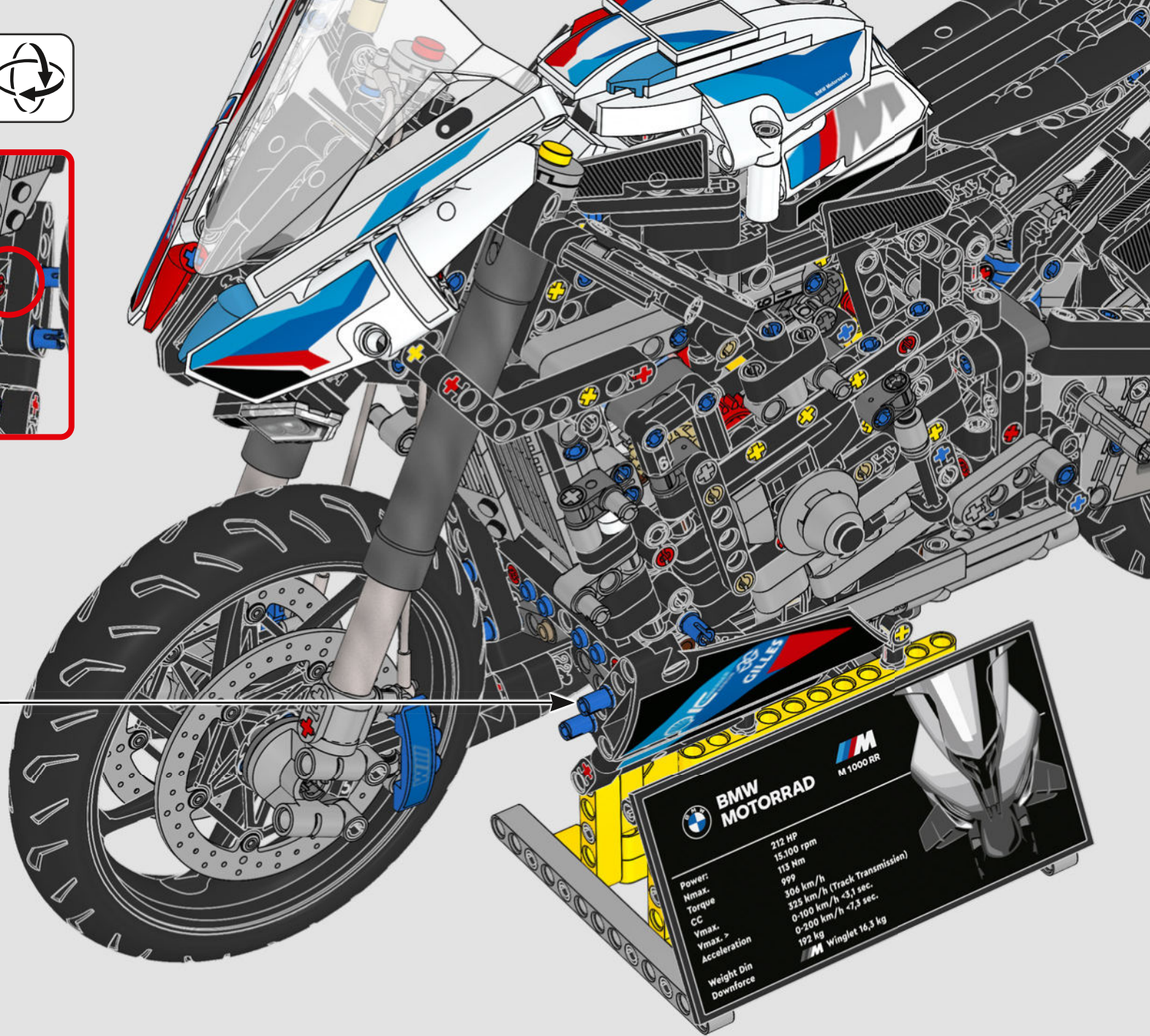
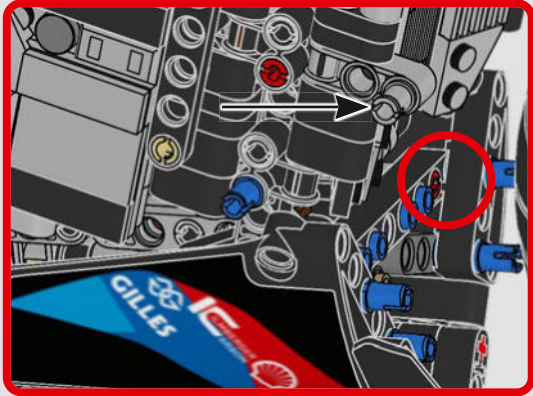

BMW MOTORRAD  **M 1000 RR**

Power:	212 HP
Nmax:	15,100 rpm
Torque:	113 Nm
CC	999
Vmax:	306 km/h
Acceleration	0-100 km/h <3,1 sec.
Weight Din	0-200 km/h <7,3 sec.
Downforce	192 kg
	Winglet 16,3 kg



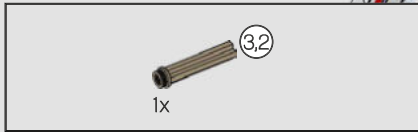

557

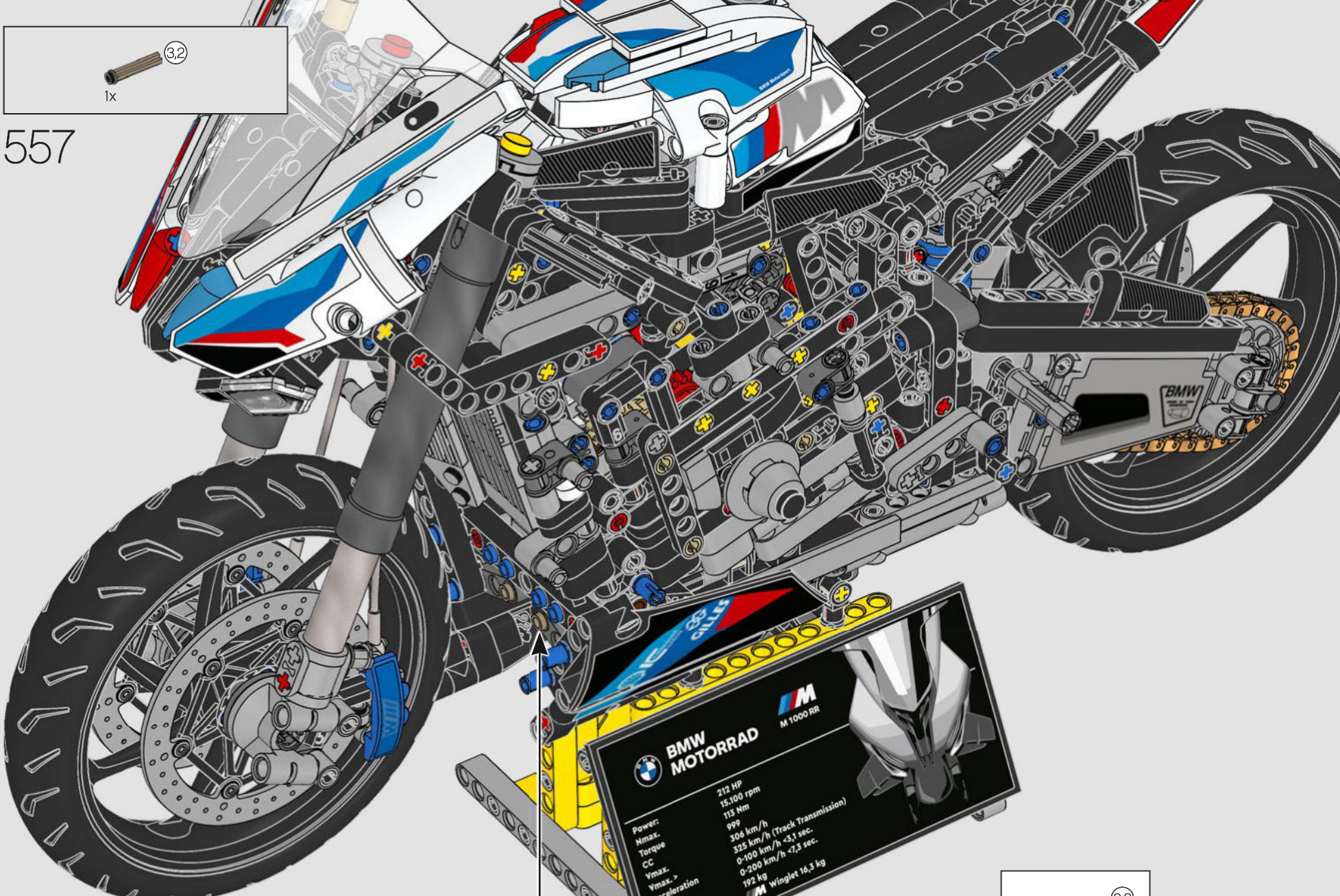

BMW MOTORRAD M 1000 RR

Power:	212 HP
Nmax:	15,100 rpm
Torque:	113 Nm
CC:	999
Ymax:	306 km/h (Track Transmission)
Acceleration:	0-100 km/h <3,1 sec.
Weight Din:	0-200 km/h <7,3 sec.
Download:	192 kg
	Winglet 16,3 kg

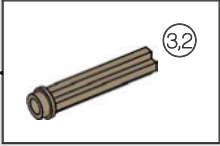

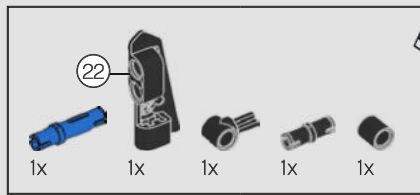

558

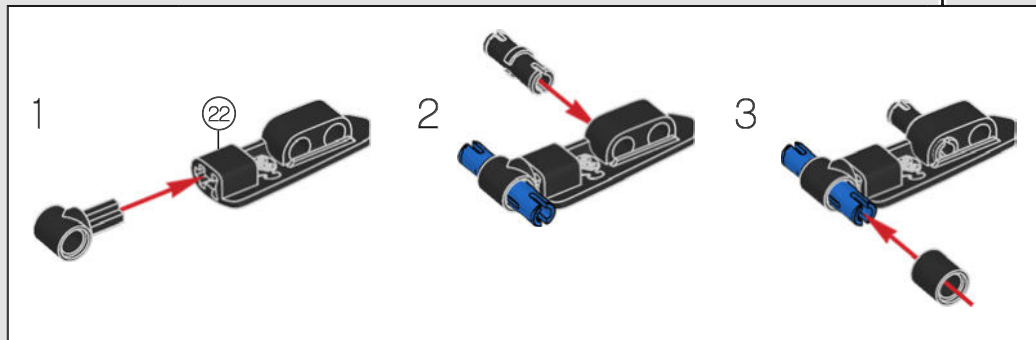
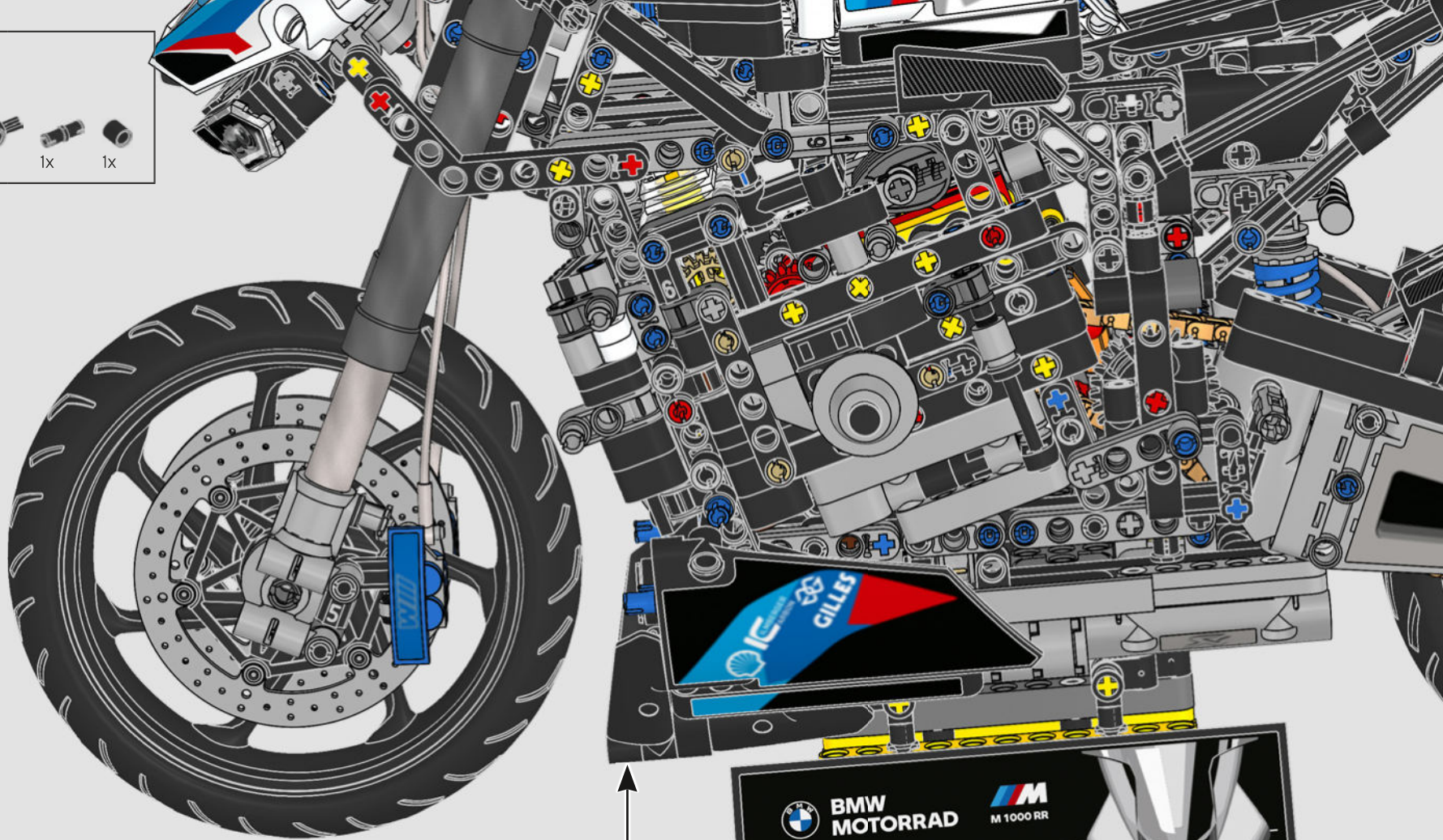

BMW MOTORRAD	M 1000 RR	
Power:	212 HP	
Nmax:	15.100 rpm	
Torque	113 Nm	
CC	999	
Vmax.	306 km/h	
Vmax. >	325 km/h (Track Transmission)	
Acceleration	0-100 km/h <3,1 sec.	
	0-200 km/h <7,3 sec.	
Weight Din	192 kg	
Downforce	Winglet 16,3 kg	

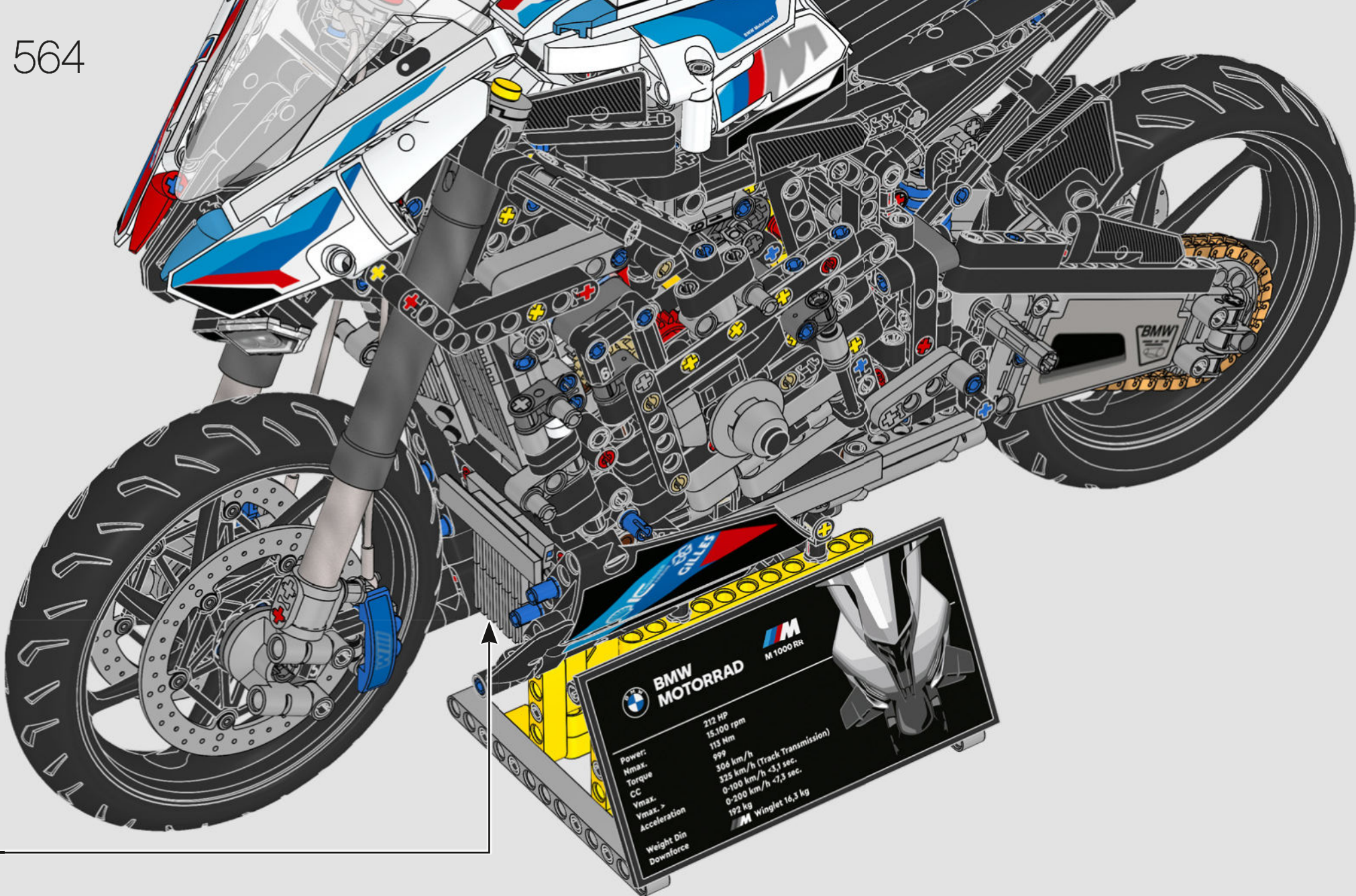

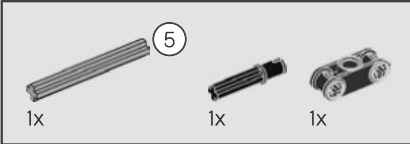
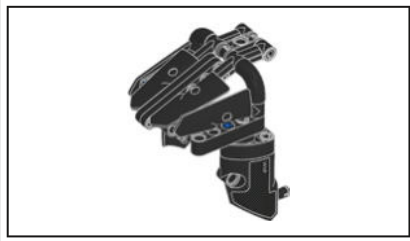

565

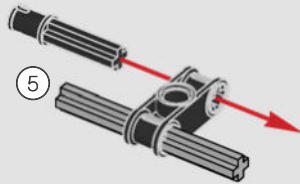

566

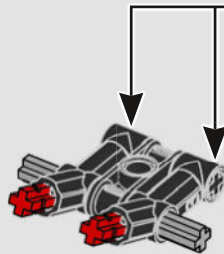
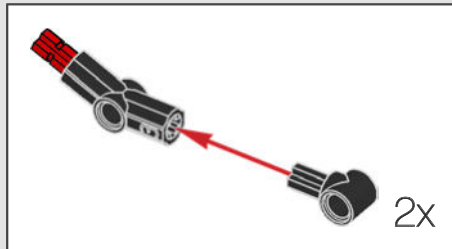

567

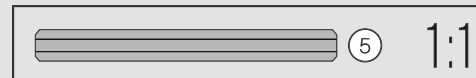
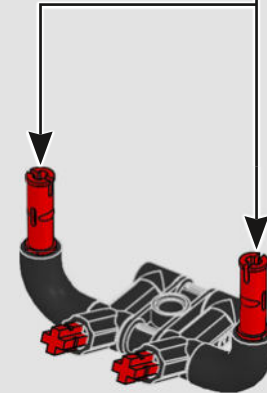

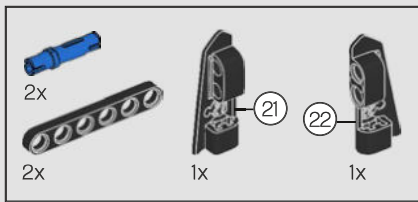

568

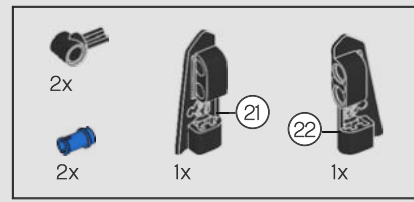
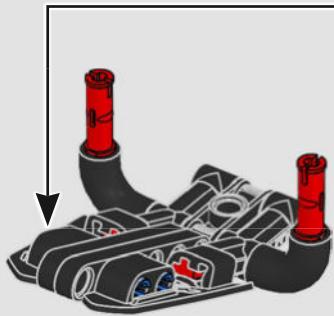
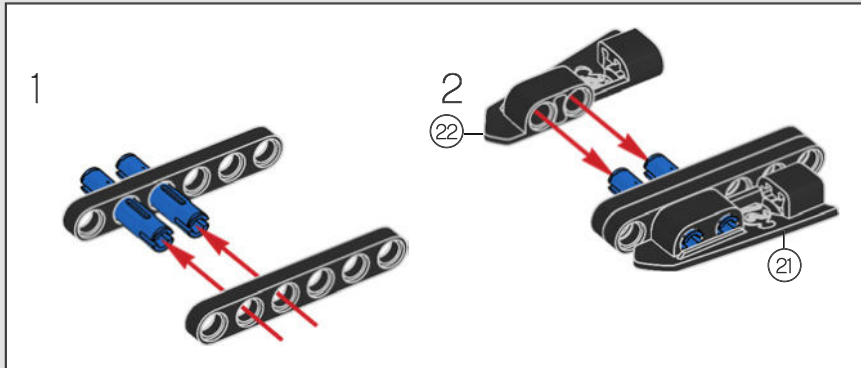
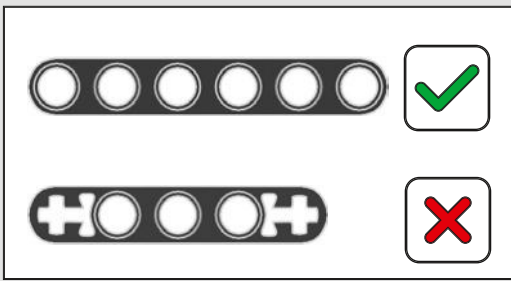

569

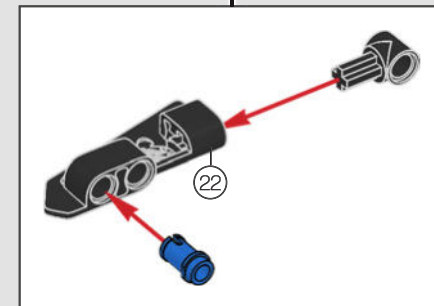
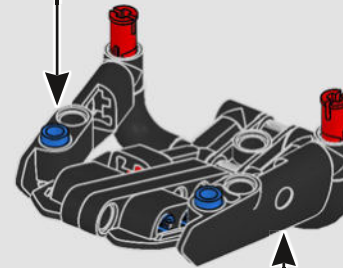
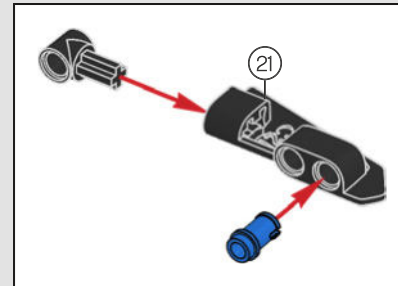

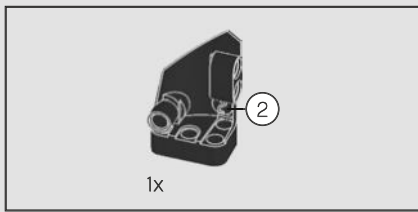

570

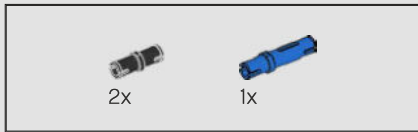
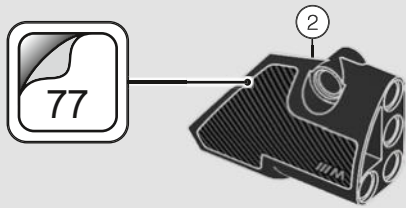

571

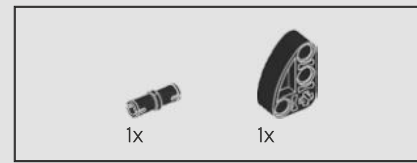
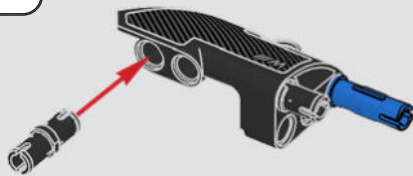

572

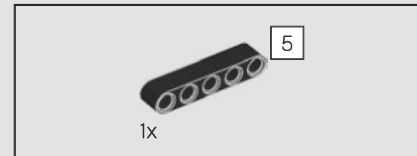
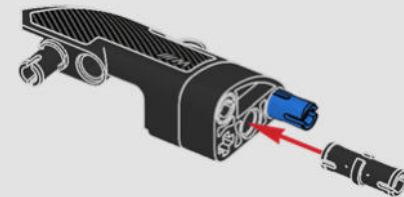

573

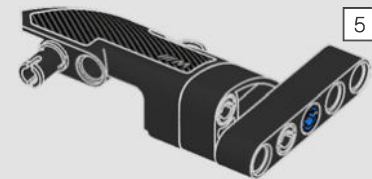

574

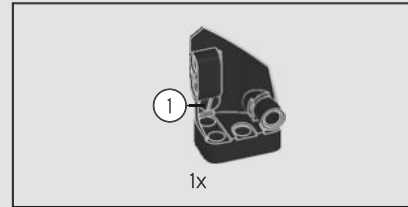
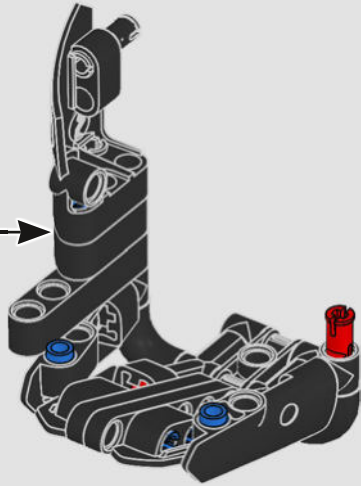

575

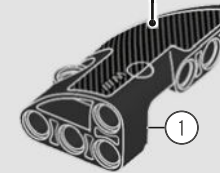

576

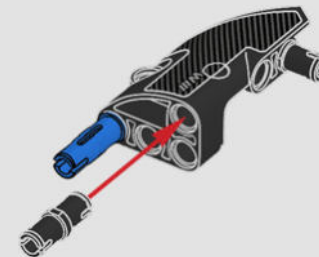

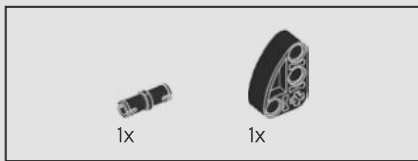

577

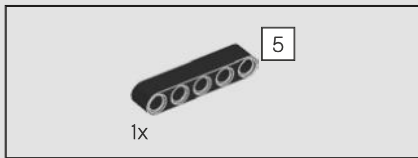
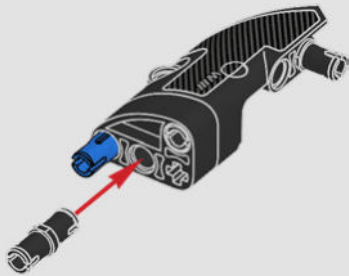

578

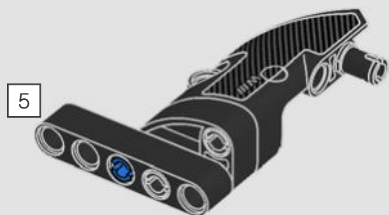

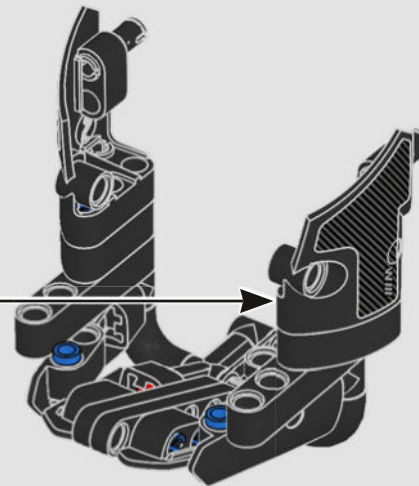

579

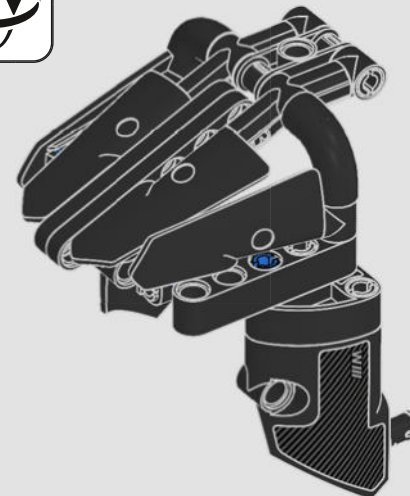

580

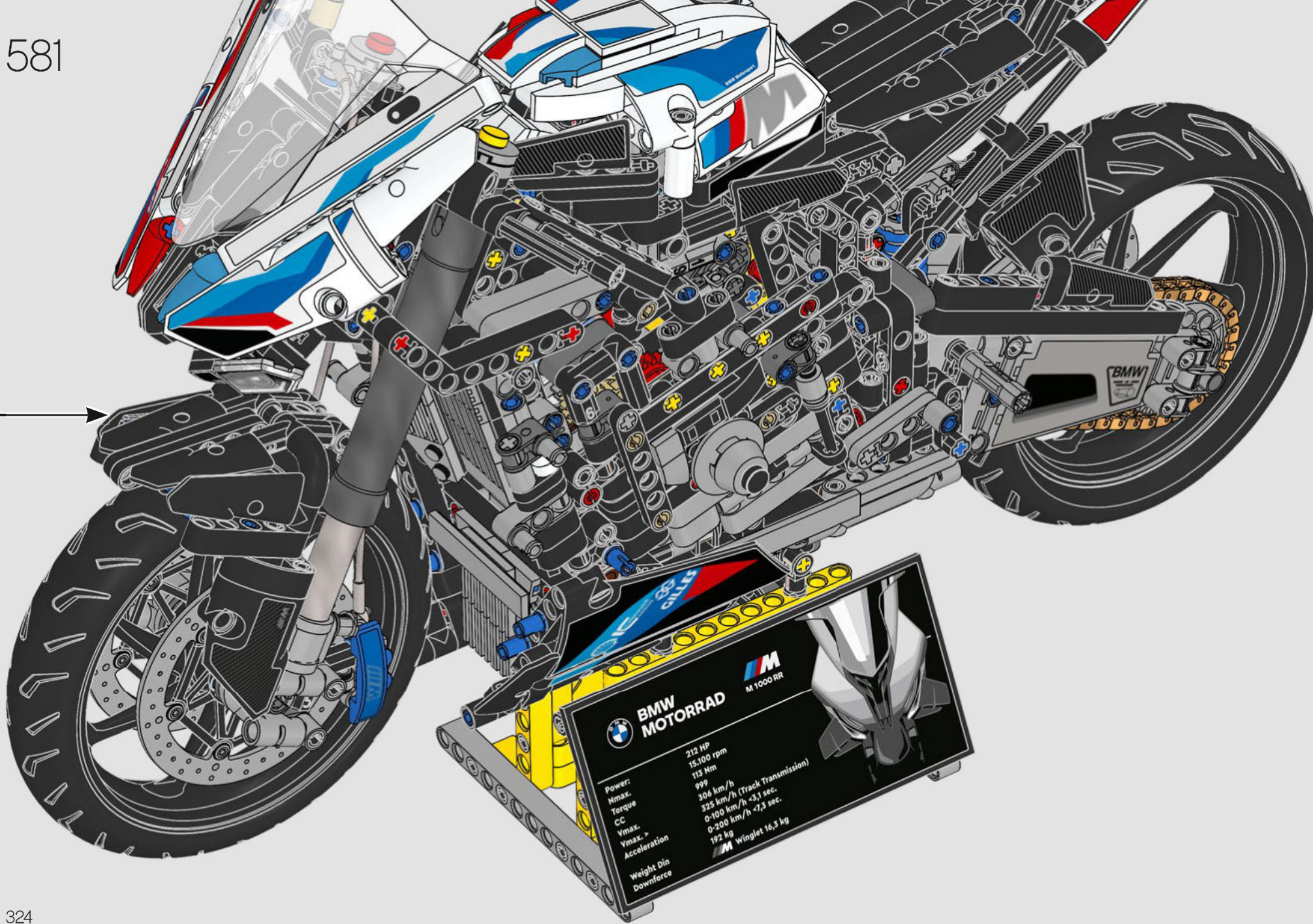



BMW MOTORRAD  **M 1000 RR**

Power:	212 HP
Nmax:	15,100 rpm
Torque:	118 Nm
CC	999
Vmax:	306 km/h
Acceleration	325 km/h (-3,1 sec.)
	0-100 km/h <7,3 sec.
	0-200 km/h <7,3 sec.
Weight Din	192 kg
Downforce	 Winglet 16,3 kg

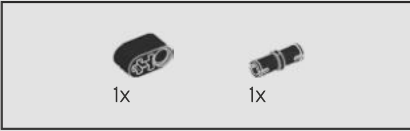
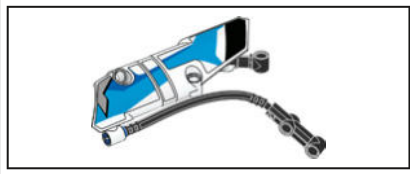

582

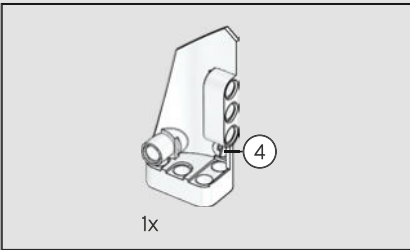
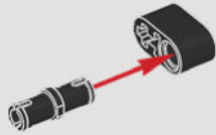

583

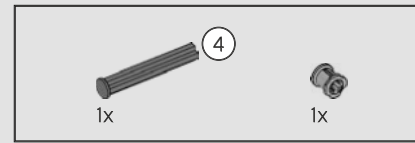
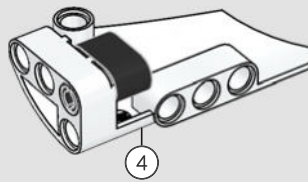

584

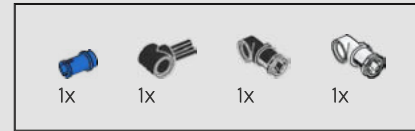
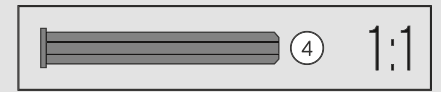
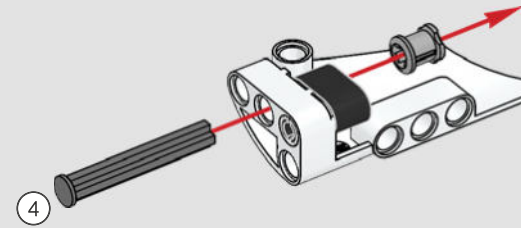

585

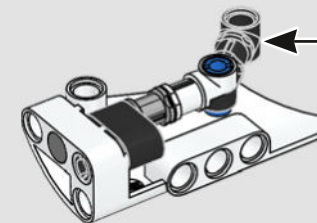
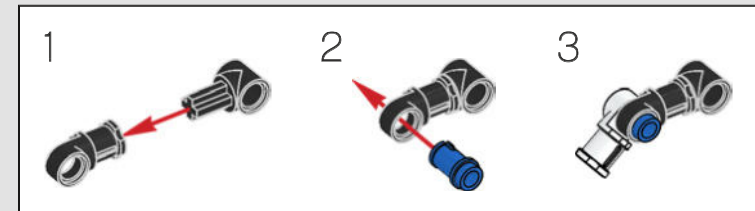

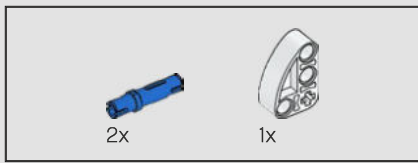

586

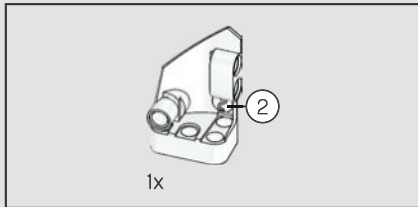
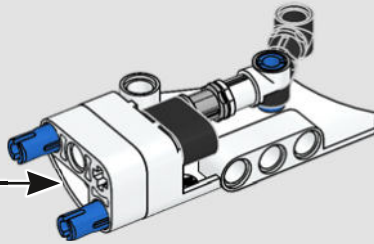
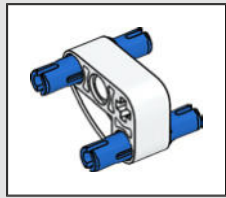

587

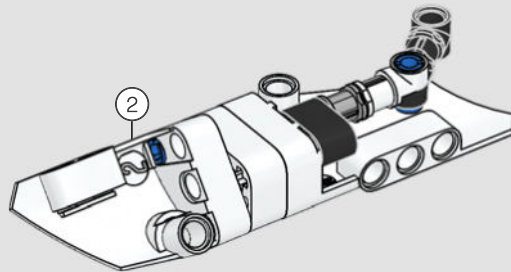

588

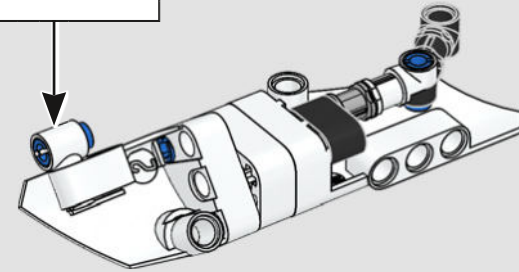
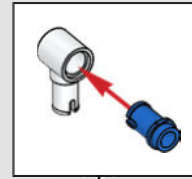

589

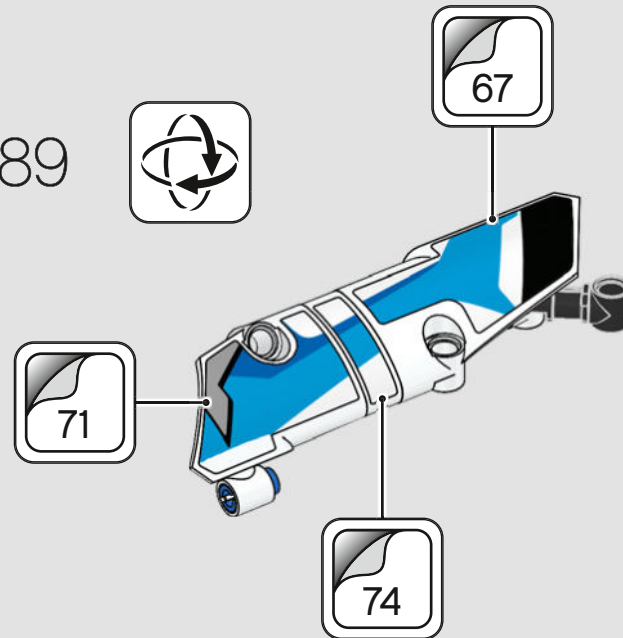



590

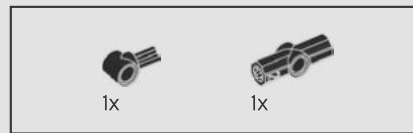
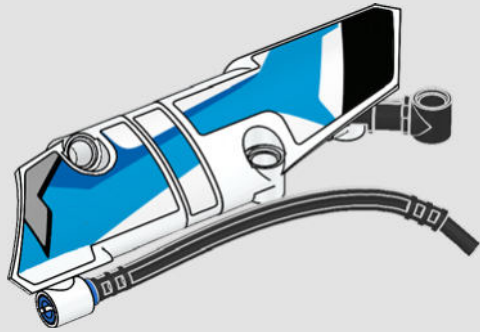

591

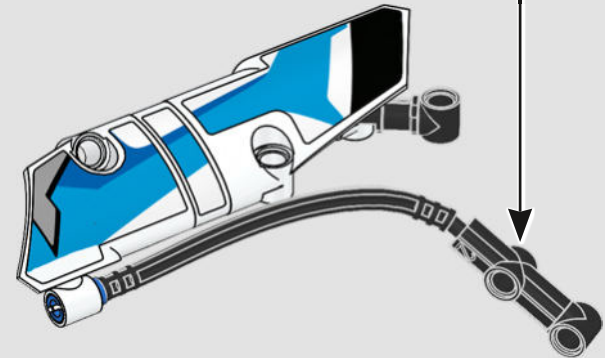
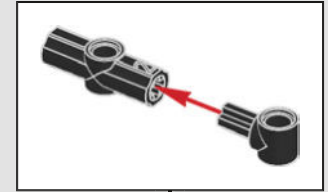

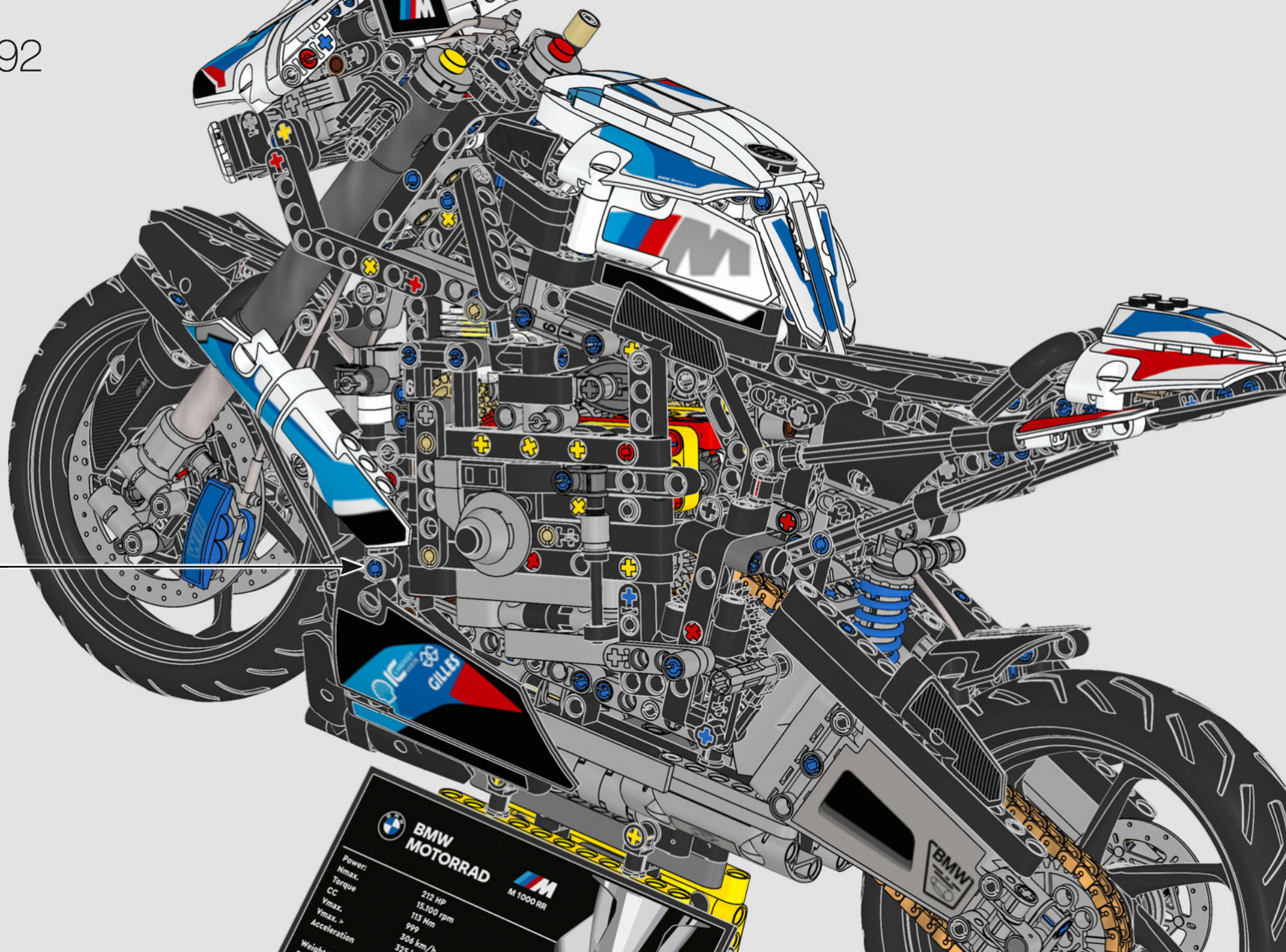

	BMW	
	MOTORRAD	M 1000 RR
Power:	212 HP	
Nmax:	15,100 rpm	
Torque	113 Nm	
CC	999	
Vmax:	306 km/h	
Vmax >	325 km/h	
Acceleration		
Weight		

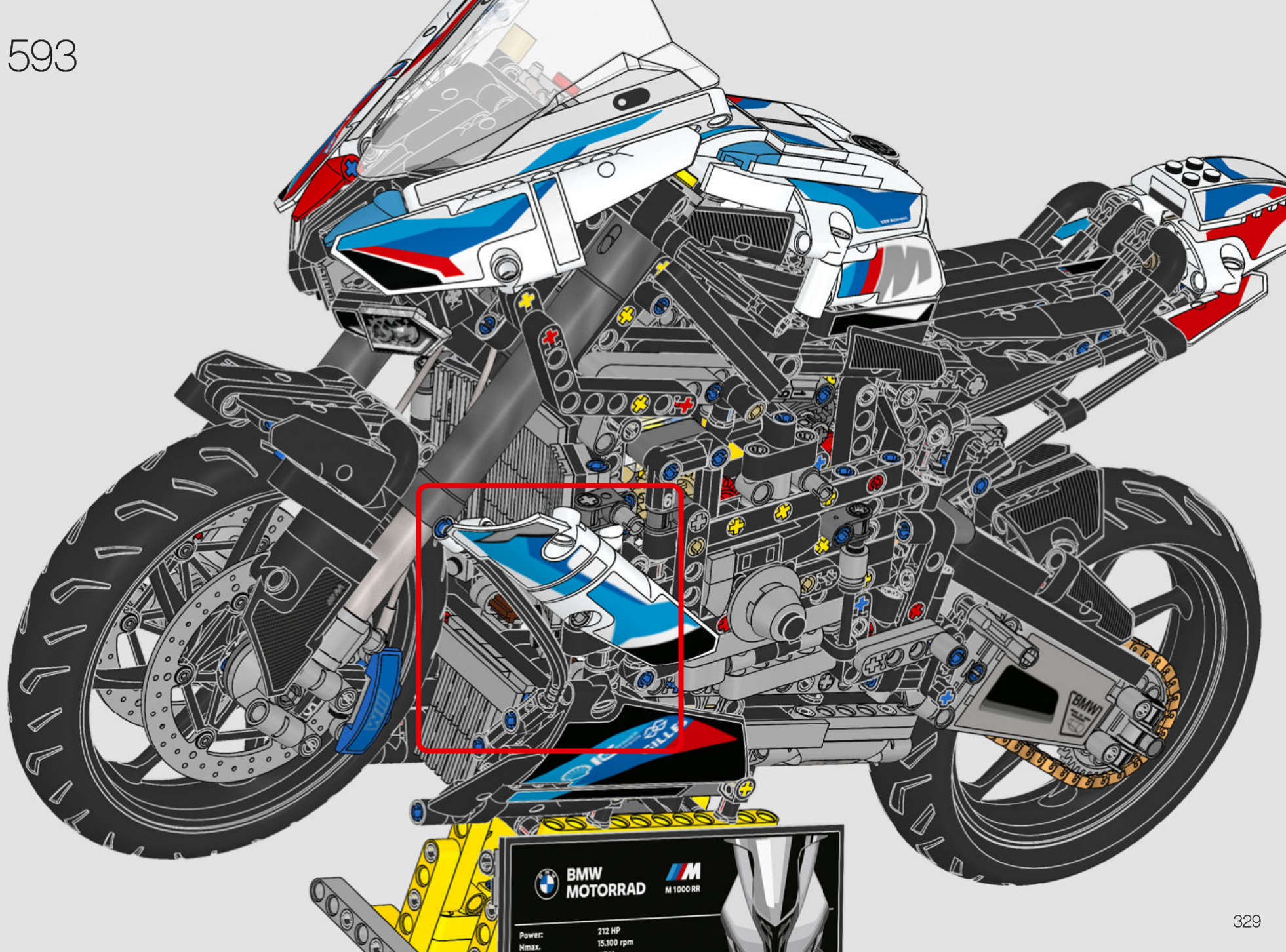

 **BMW**
MOTORRAD

 **M**
M 1000 RR

Power: 212 HP
Nmax. 15.100 rpm

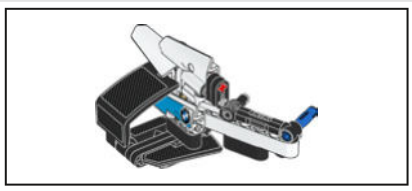

594

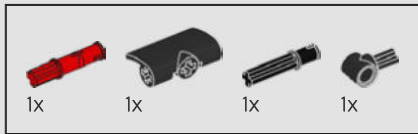
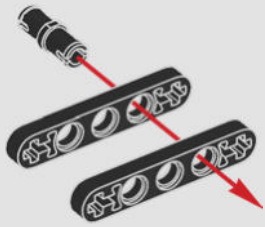

595

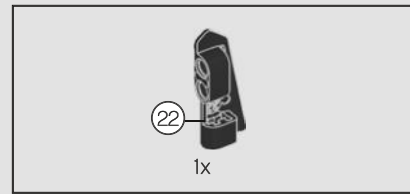
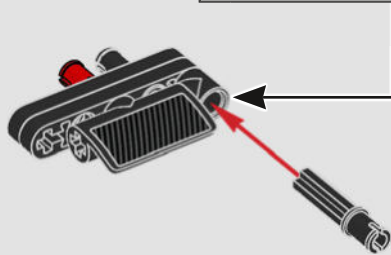
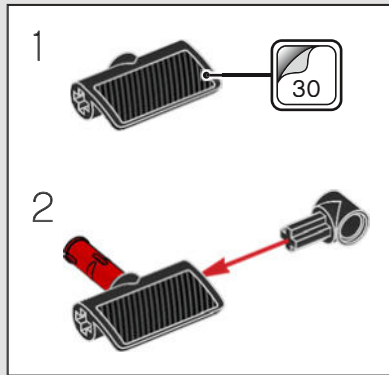

596

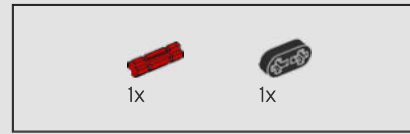
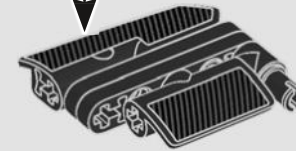
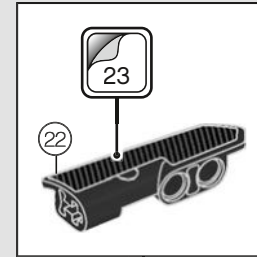

597

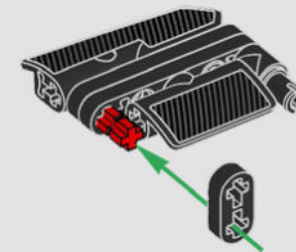

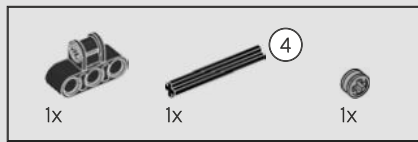

598

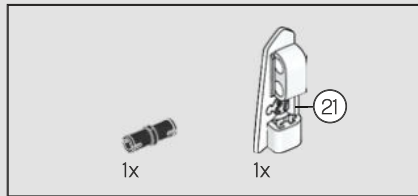
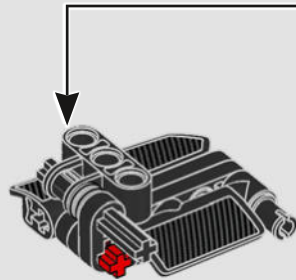
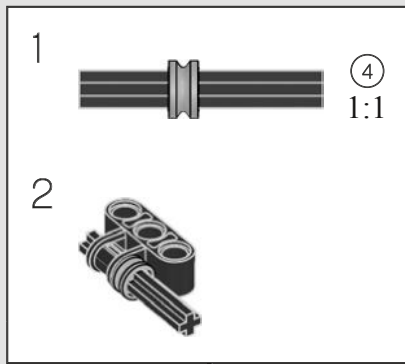

599

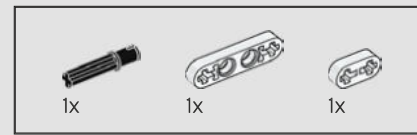
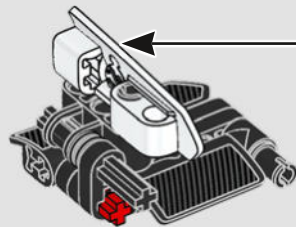
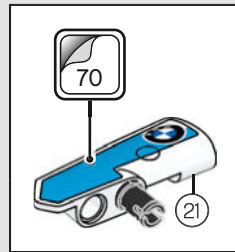

600

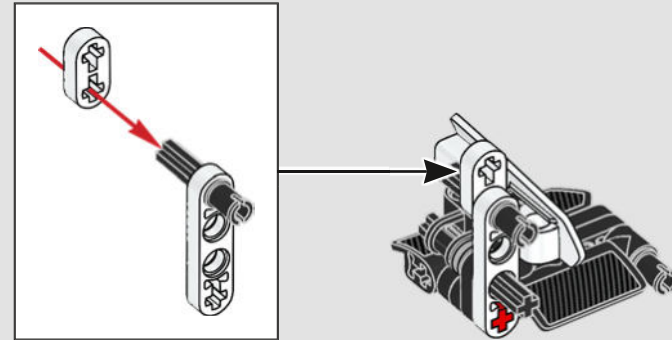

601

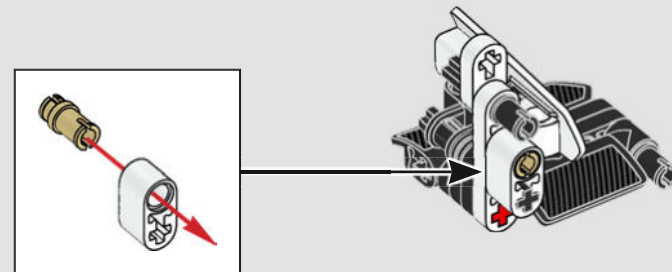

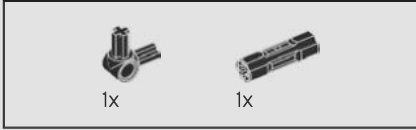
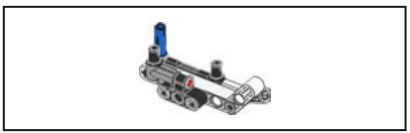

602

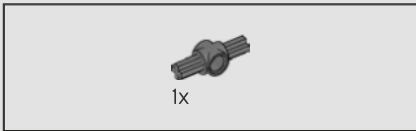
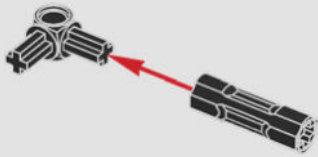

603

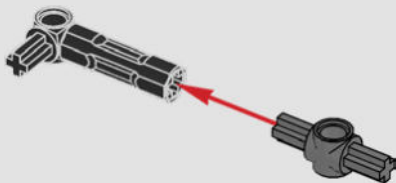

604

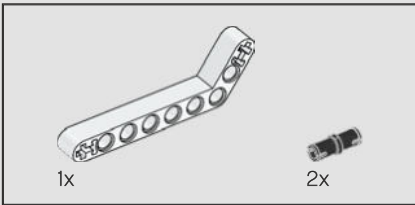
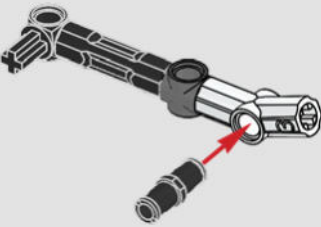

605

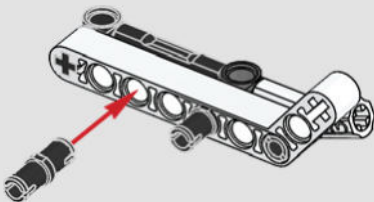



606

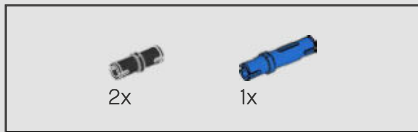
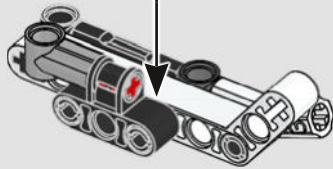
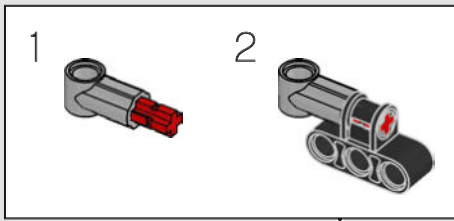

607

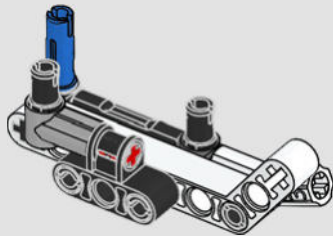

608

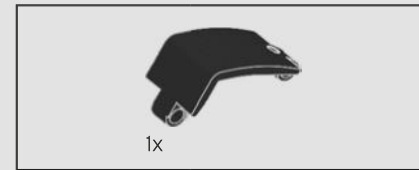
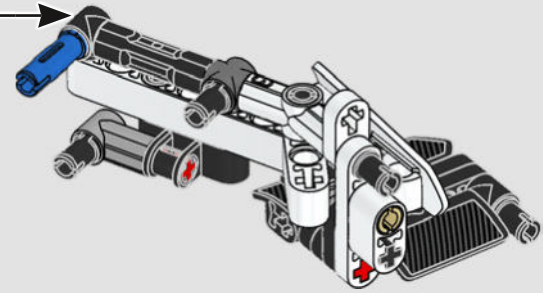

609

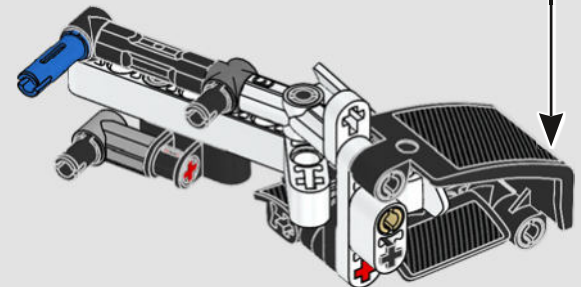
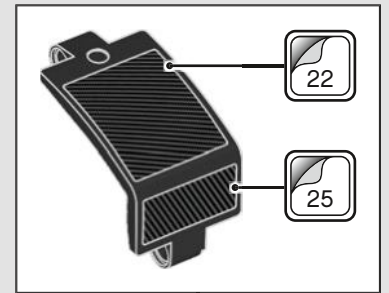

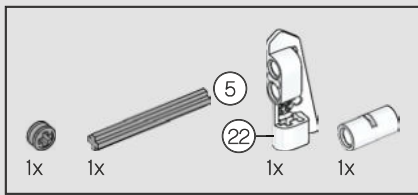

610

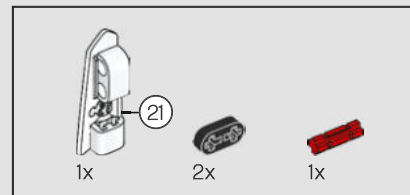
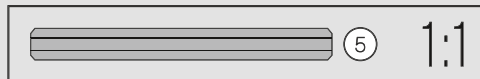
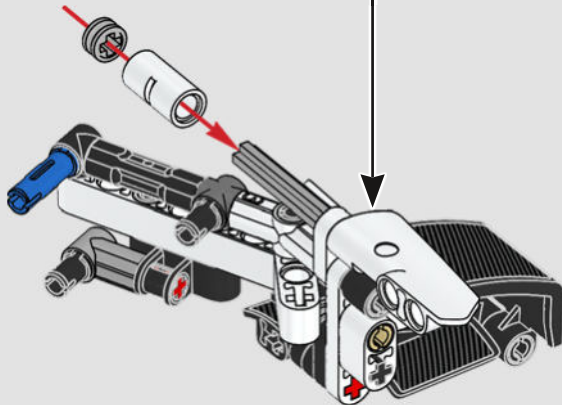
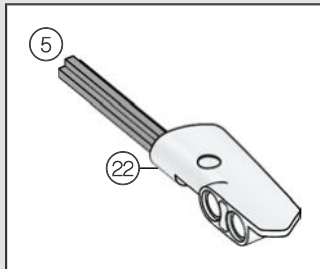

611

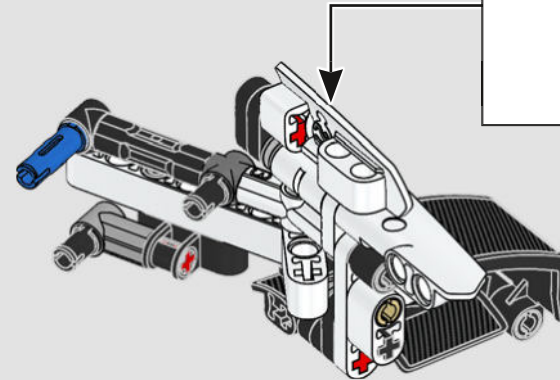
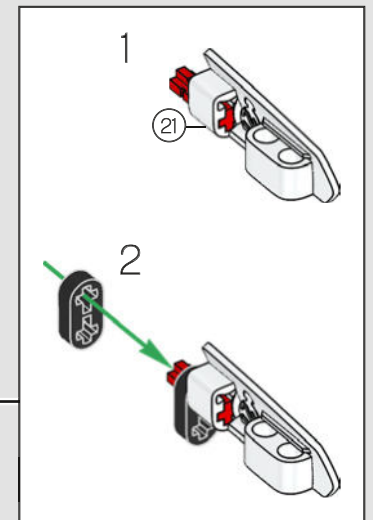

612

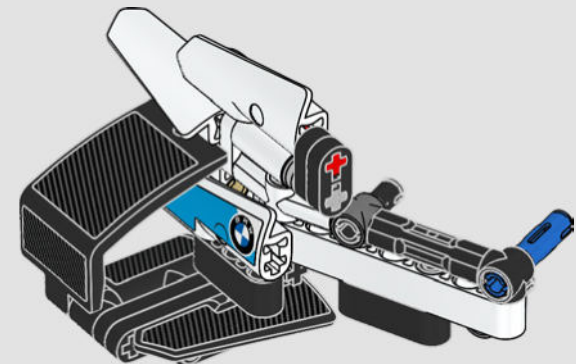

613

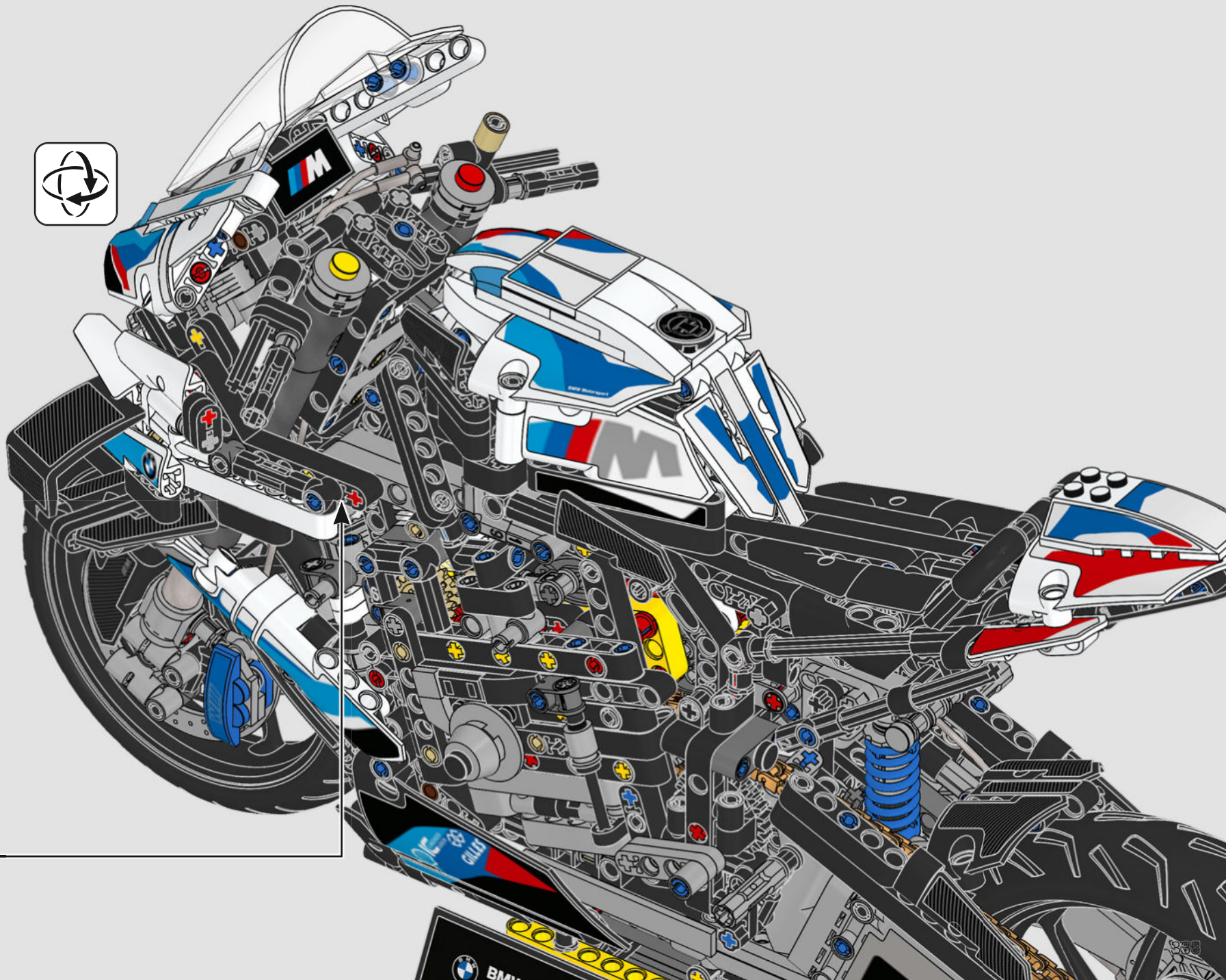

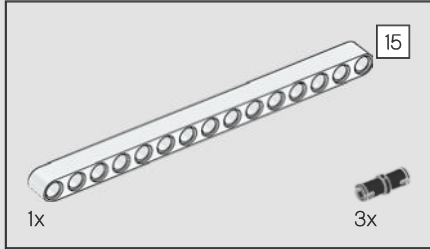
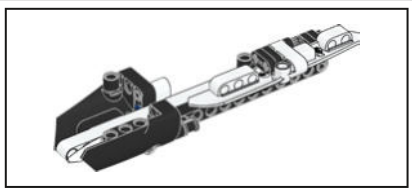

614

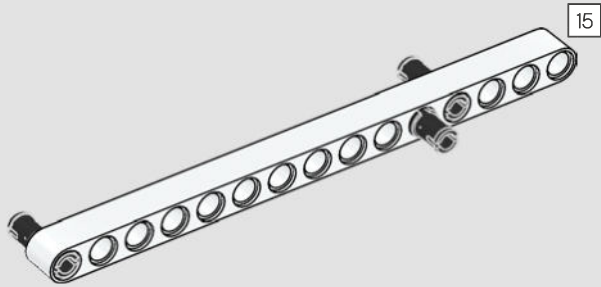

615

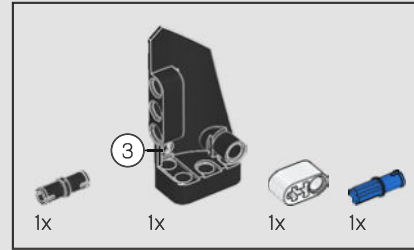
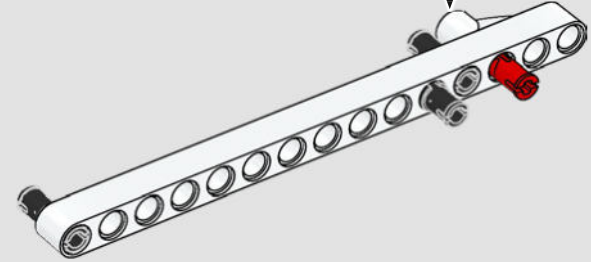

616

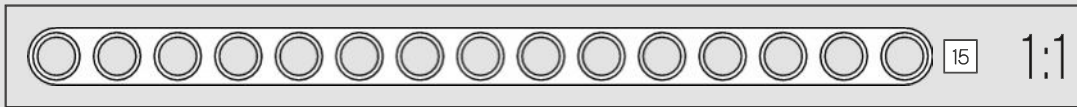
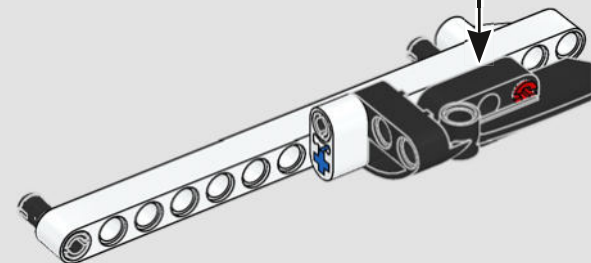
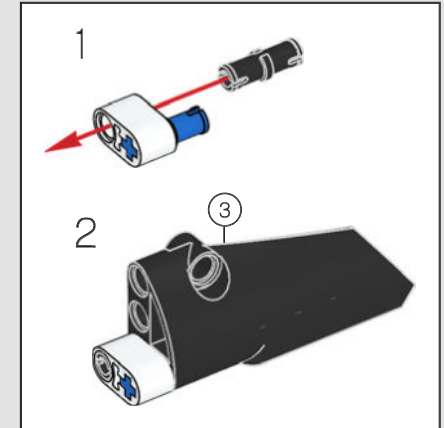

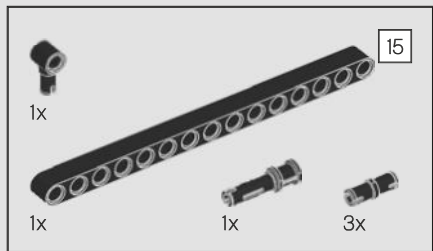

617 1

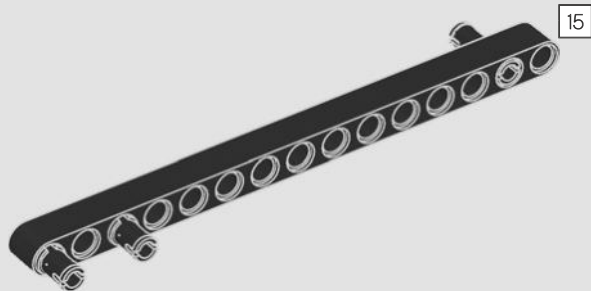

2

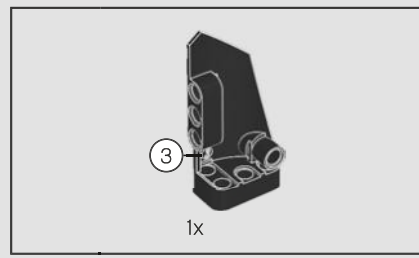
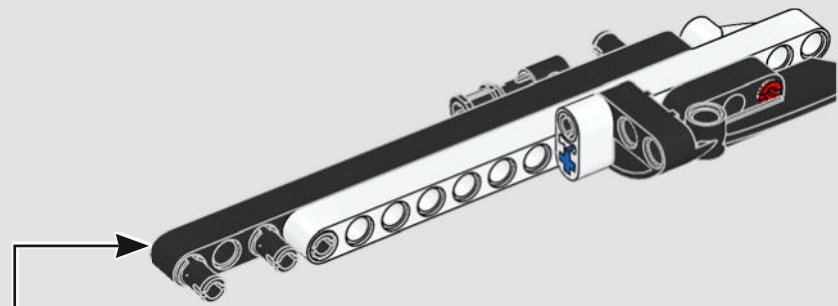
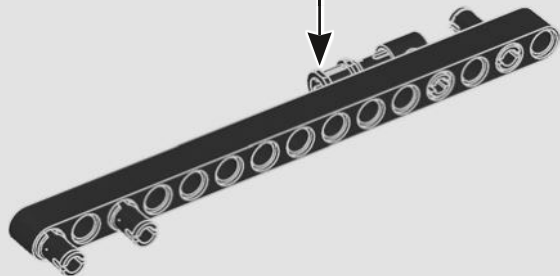

618

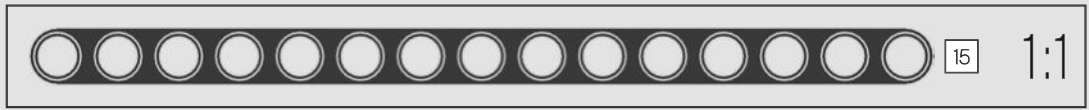
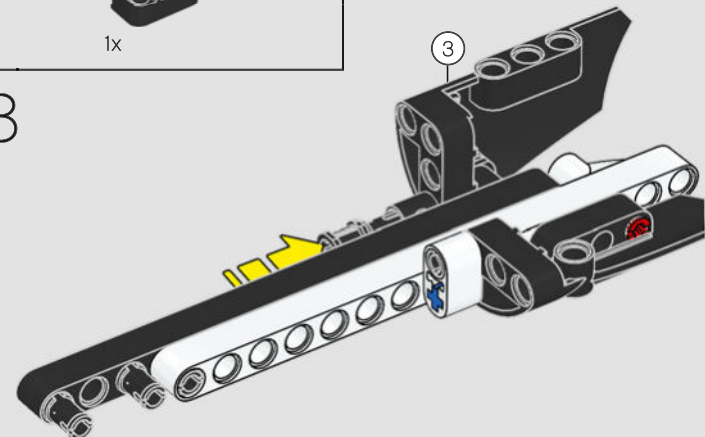

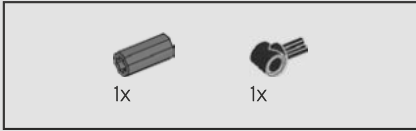
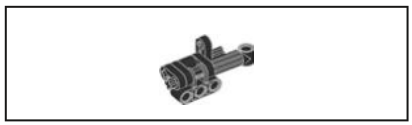

619

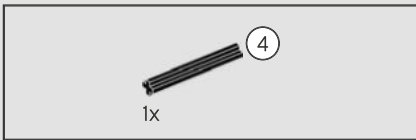
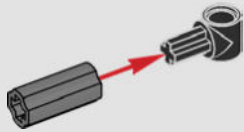

620

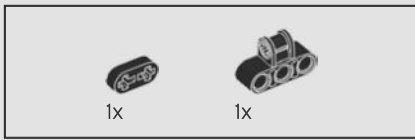
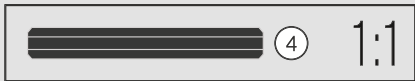
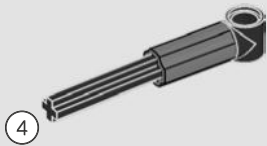

621

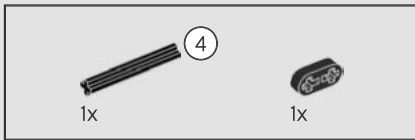
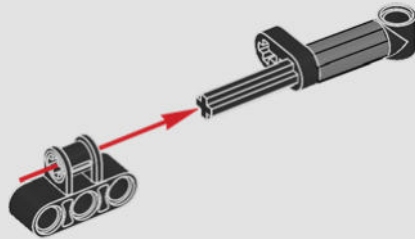

622

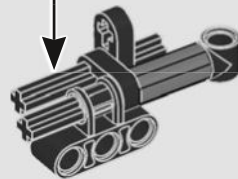
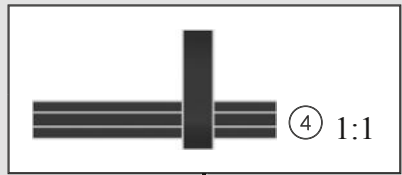



623

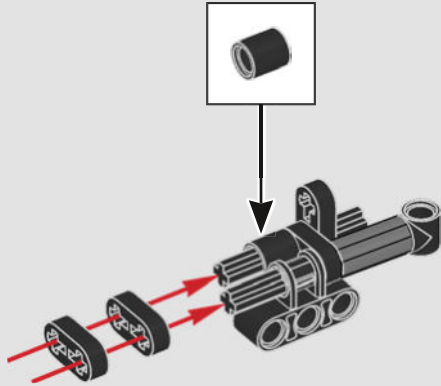

624

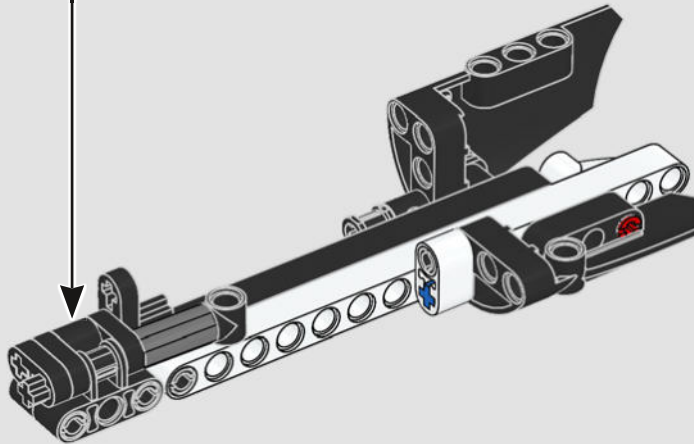

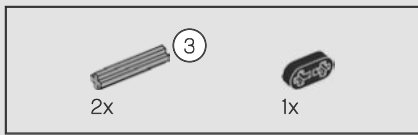

625

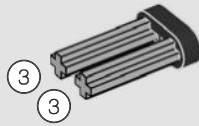

626

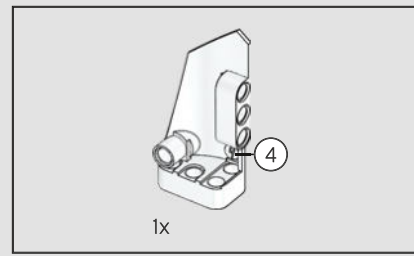
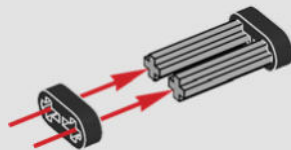

627

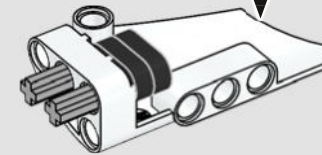
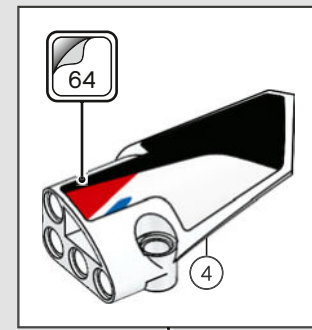

628

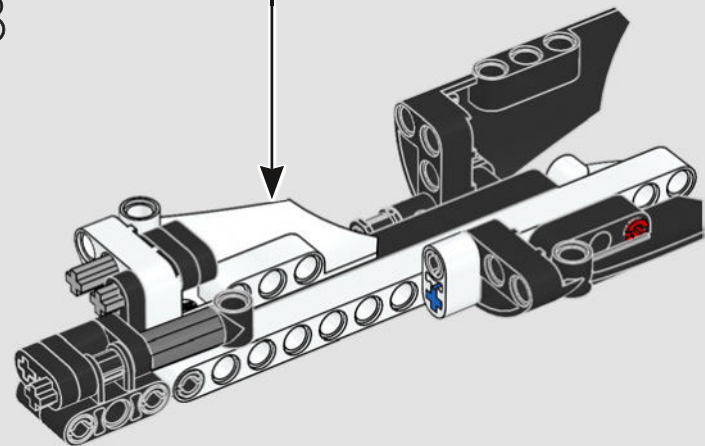

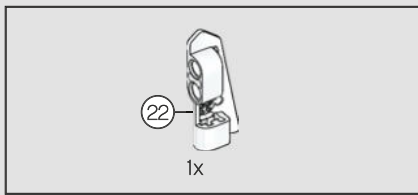

629

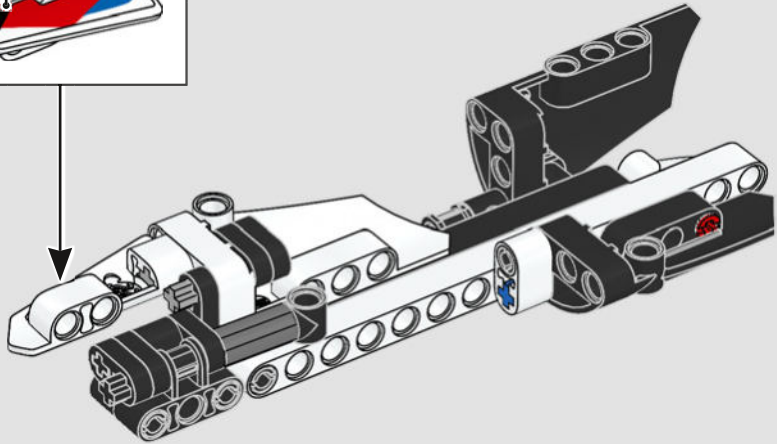
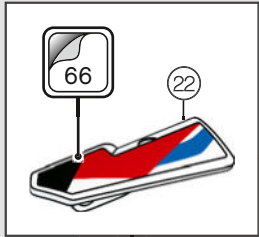

630

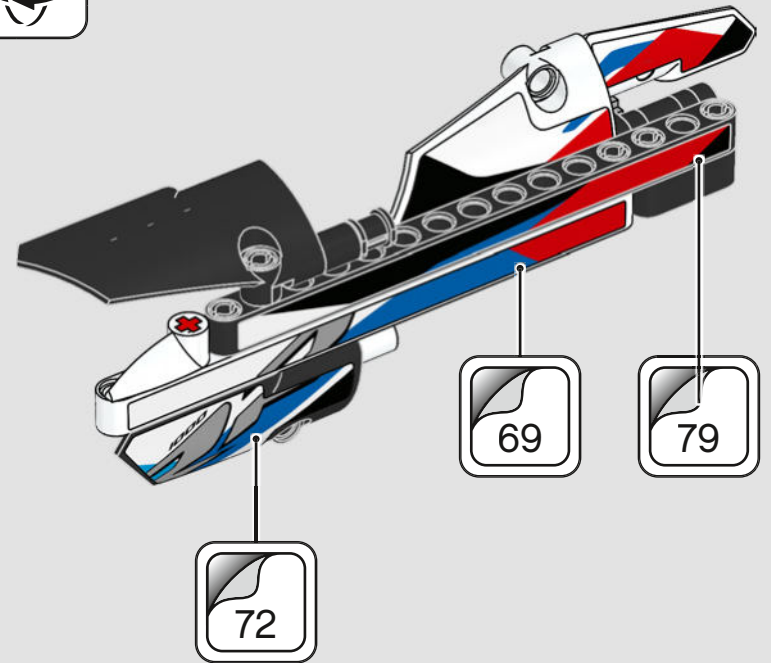

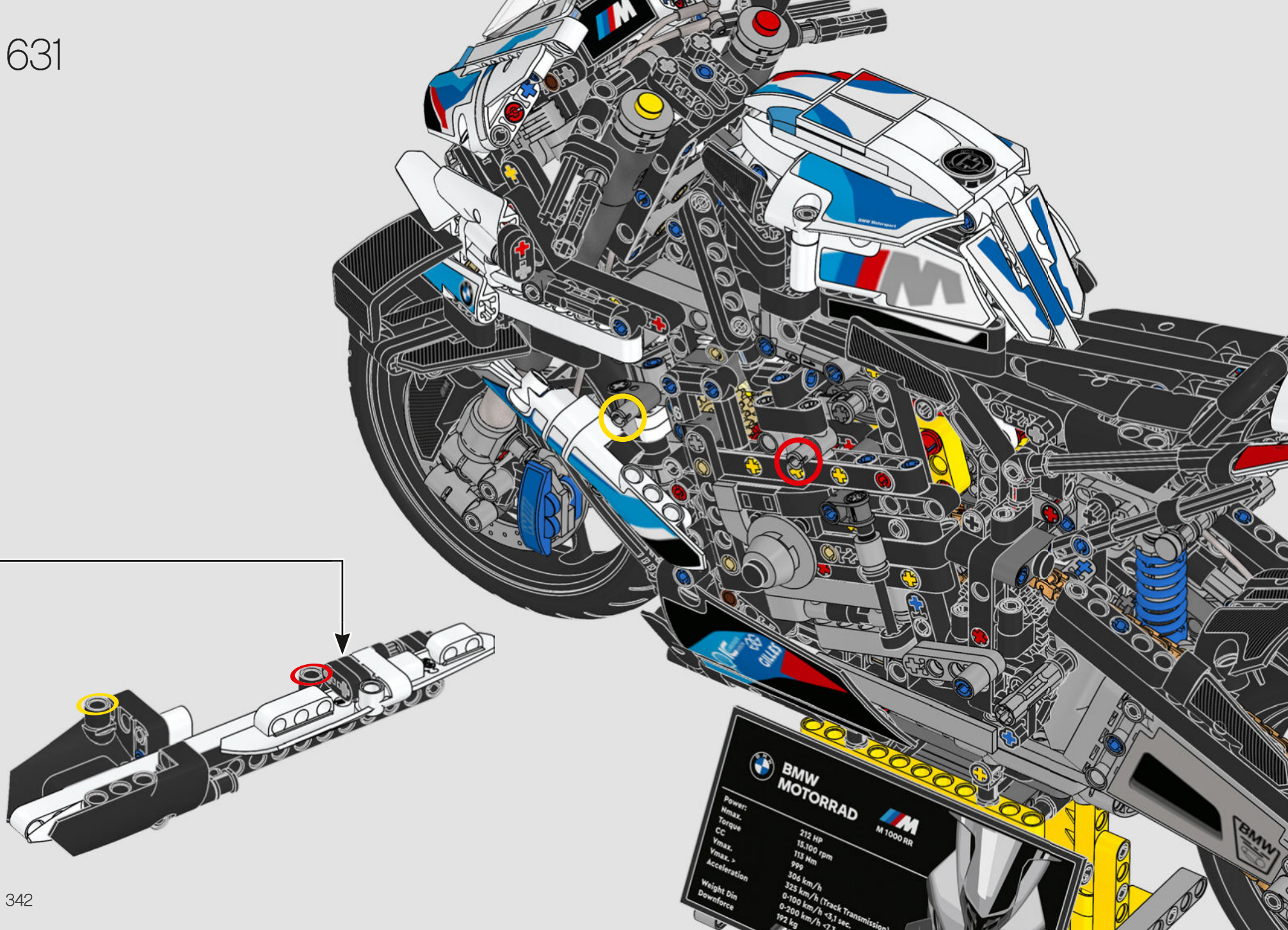

BMW MOTORRAD		M 1000 RR	
Power	212 HP		
Nmax	15,100 rpm		
Torque	113 Nm		
CC	999		
Vmax	306 km/h		
Vmax >	325 km/h (Track Transmission)		
Acceleration	0-100 km/h < 3,1 sec.		
Weight Din	0-200 km/h < 7,3 sec.		
Downforce	192 kg		

632

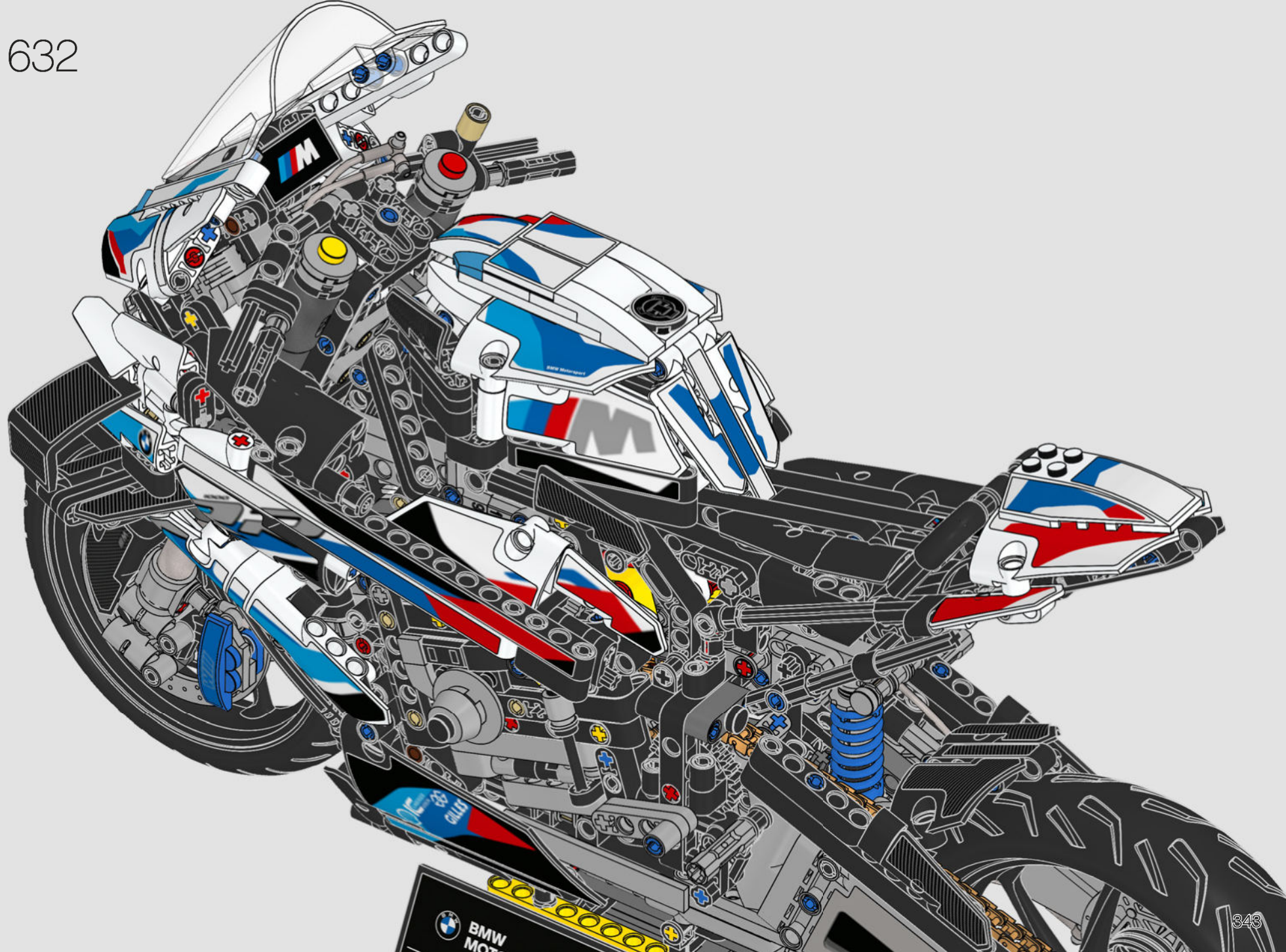

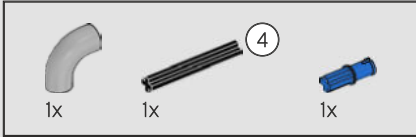
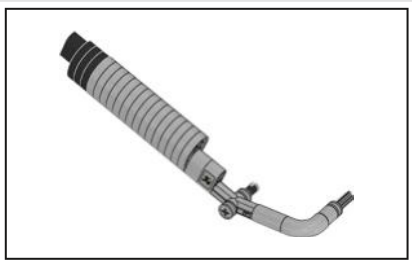

633

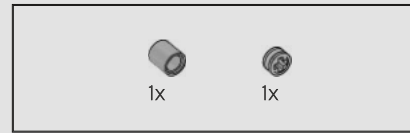
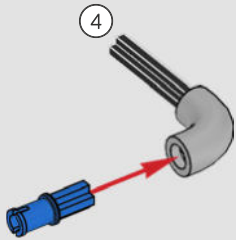

634

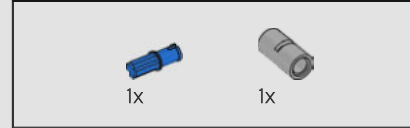
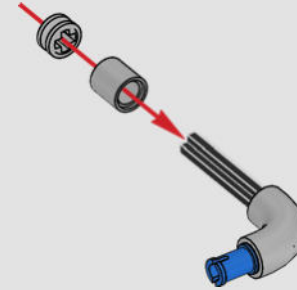

635

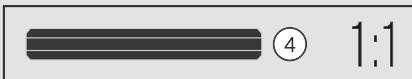
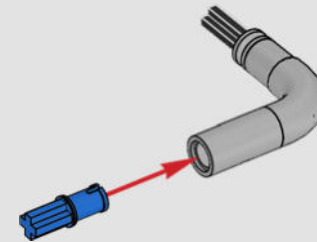

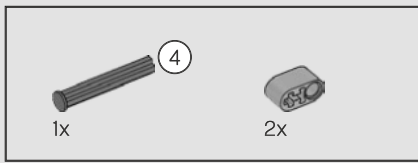

636

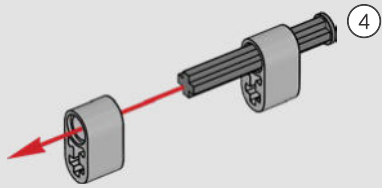

637

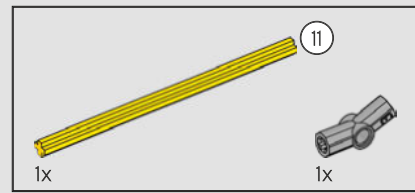
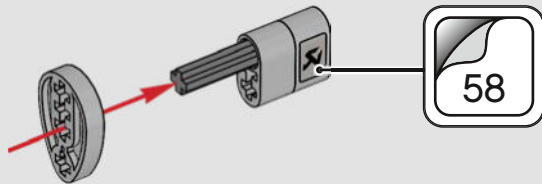

638

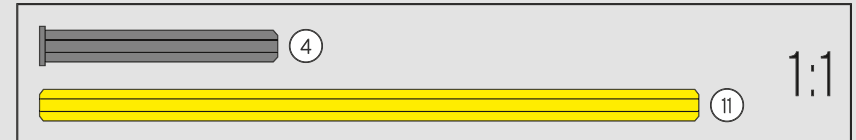
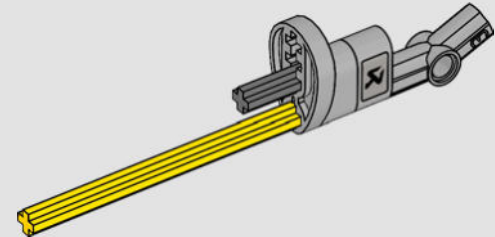
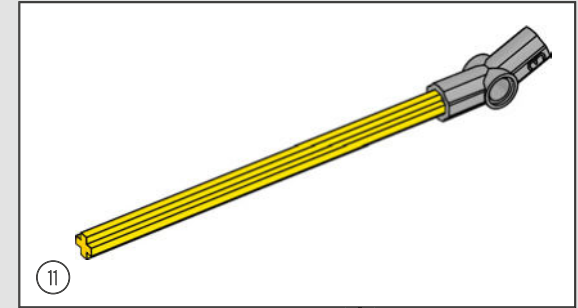



4x

639

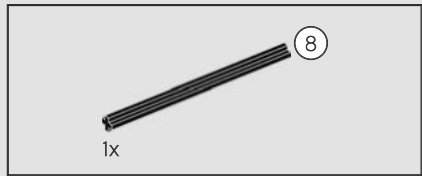
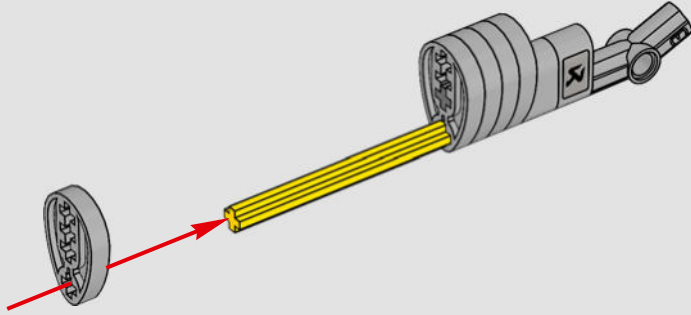

1x

640

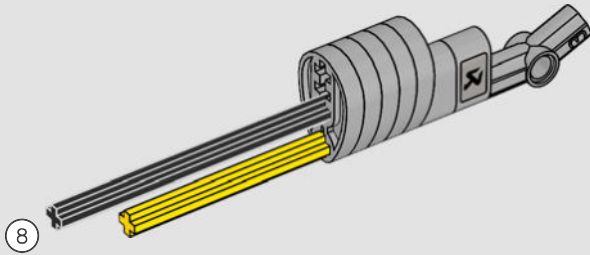

10x

641

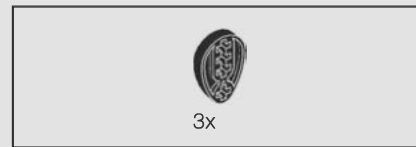
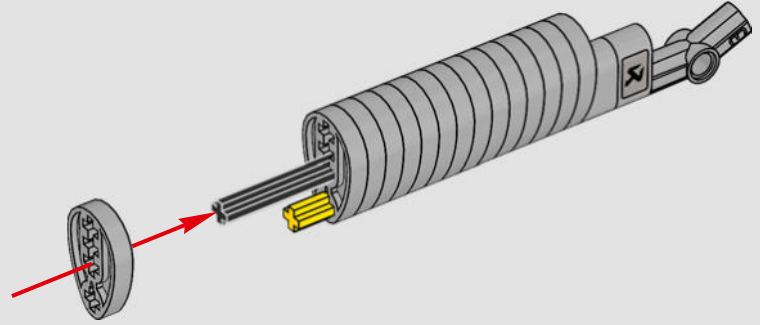

3x

642

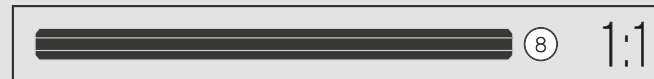
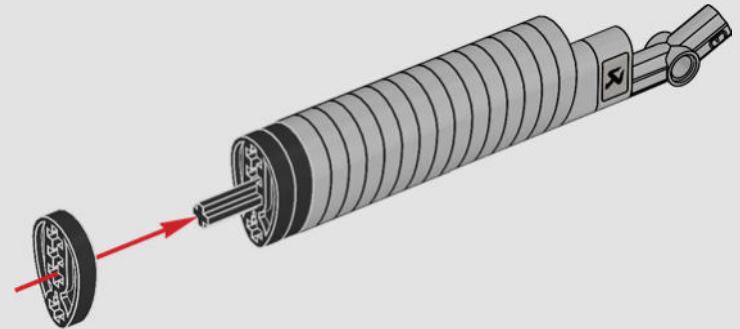

8

1:1

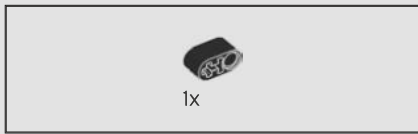

643

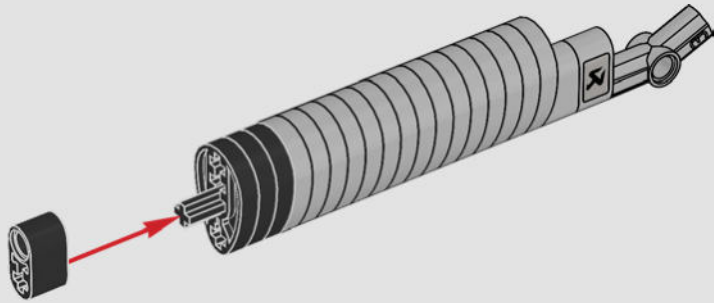

644

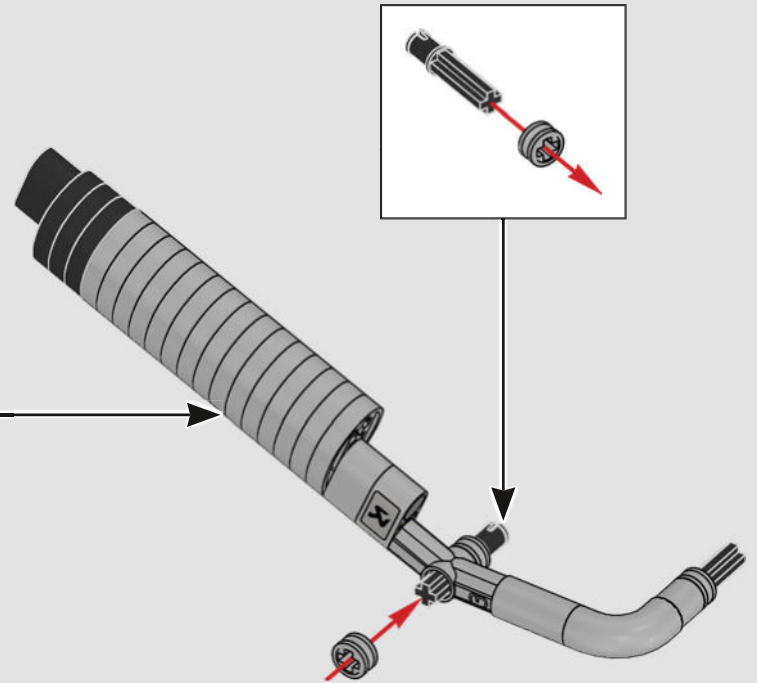

645

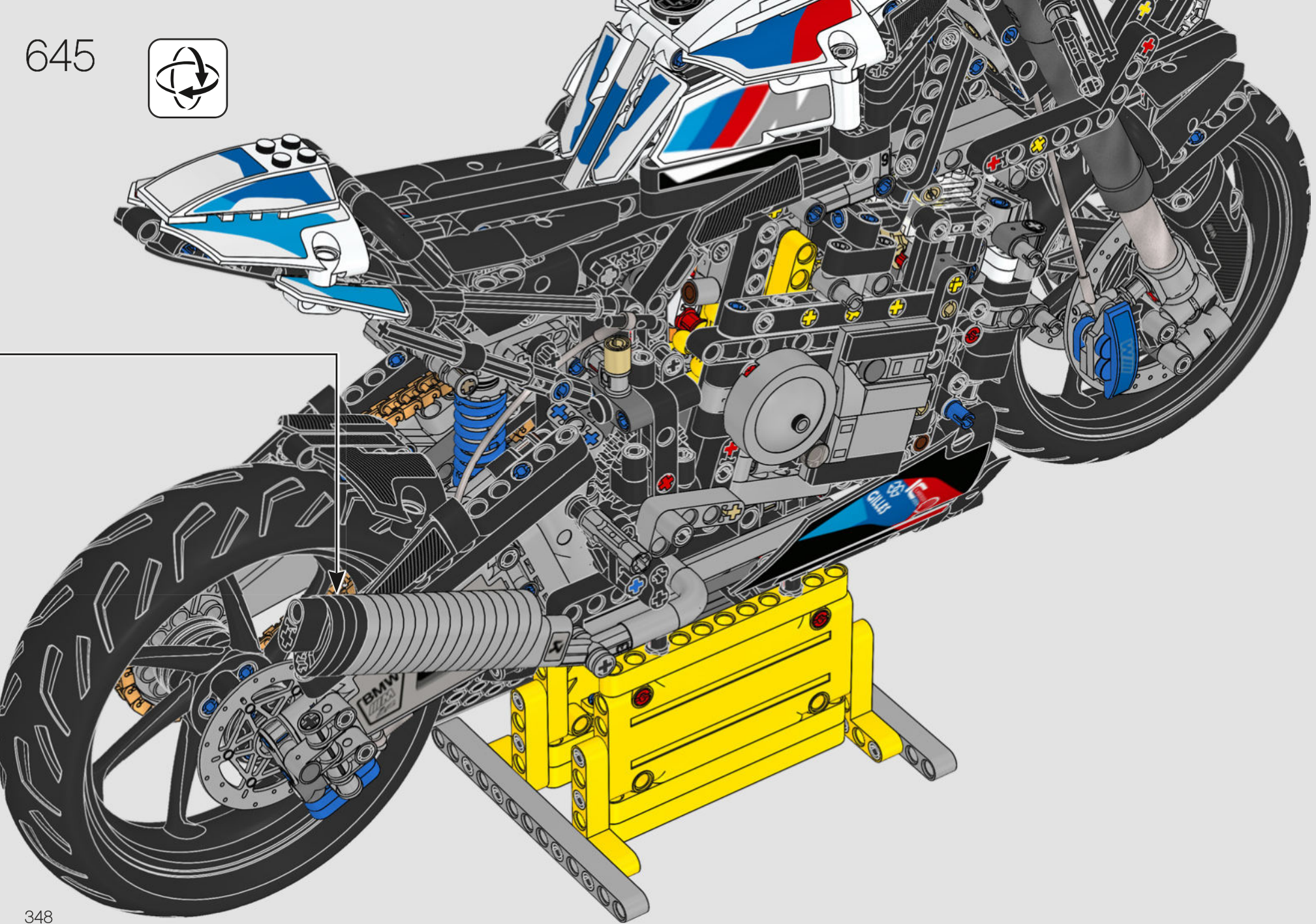

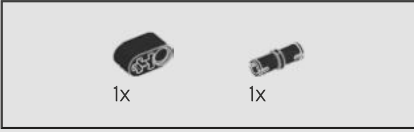
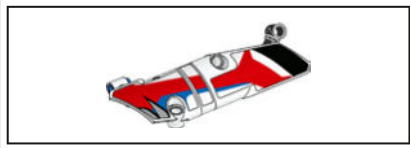

646

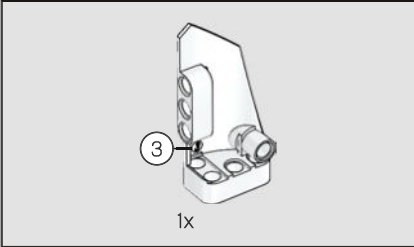
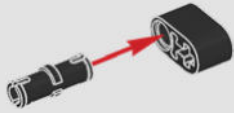

647

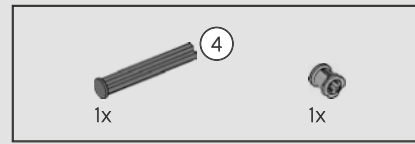
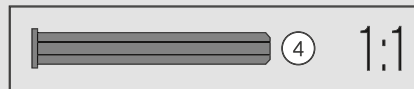
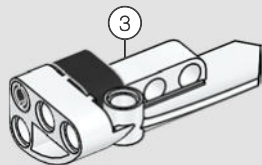

648

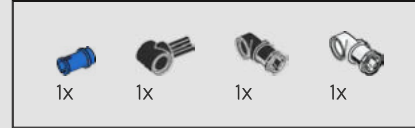
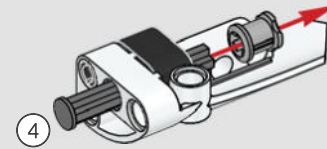

649

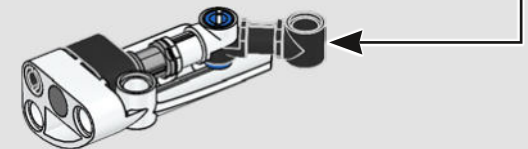
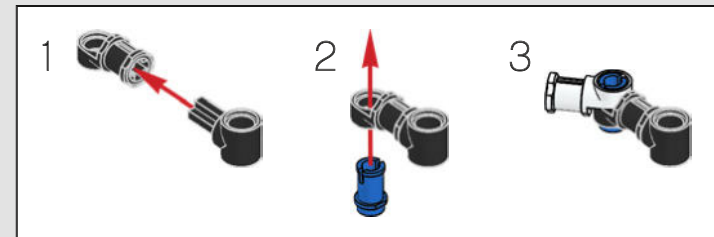

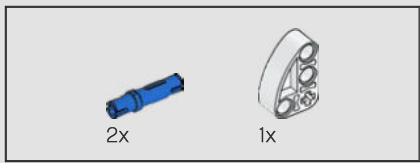

650

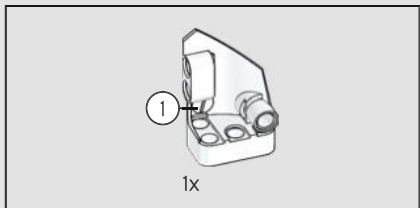
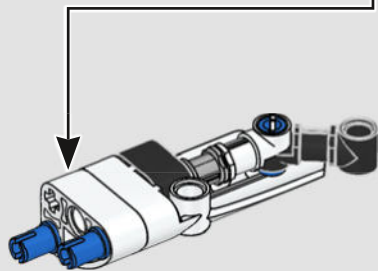
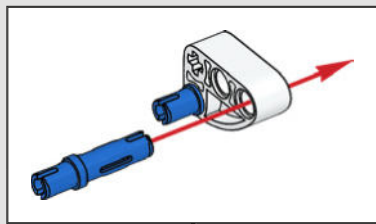

651

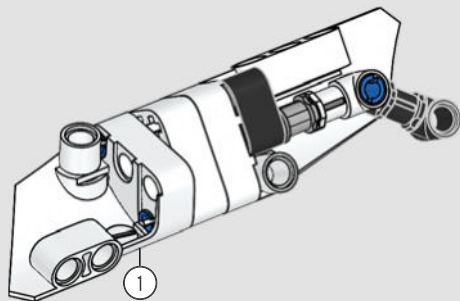

652

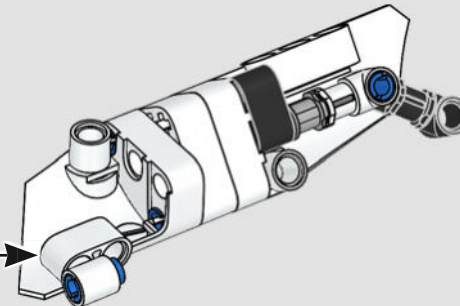
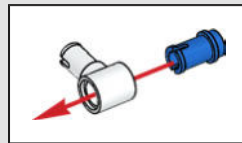

653

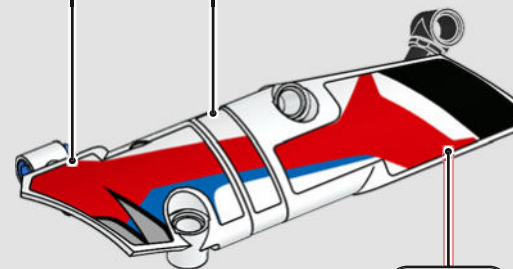
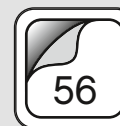



654

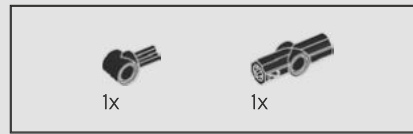
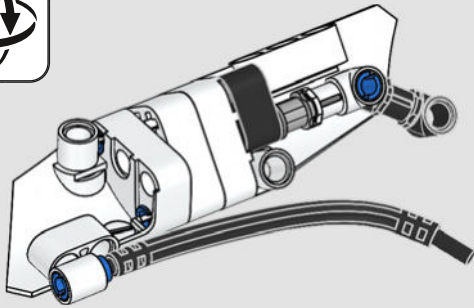

655

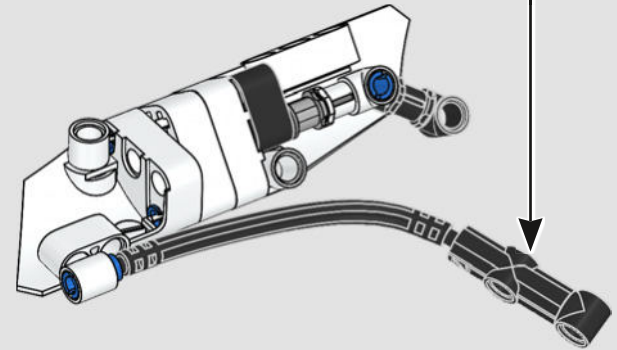
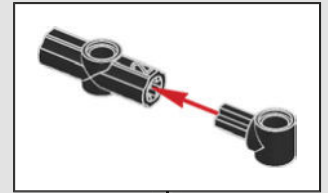

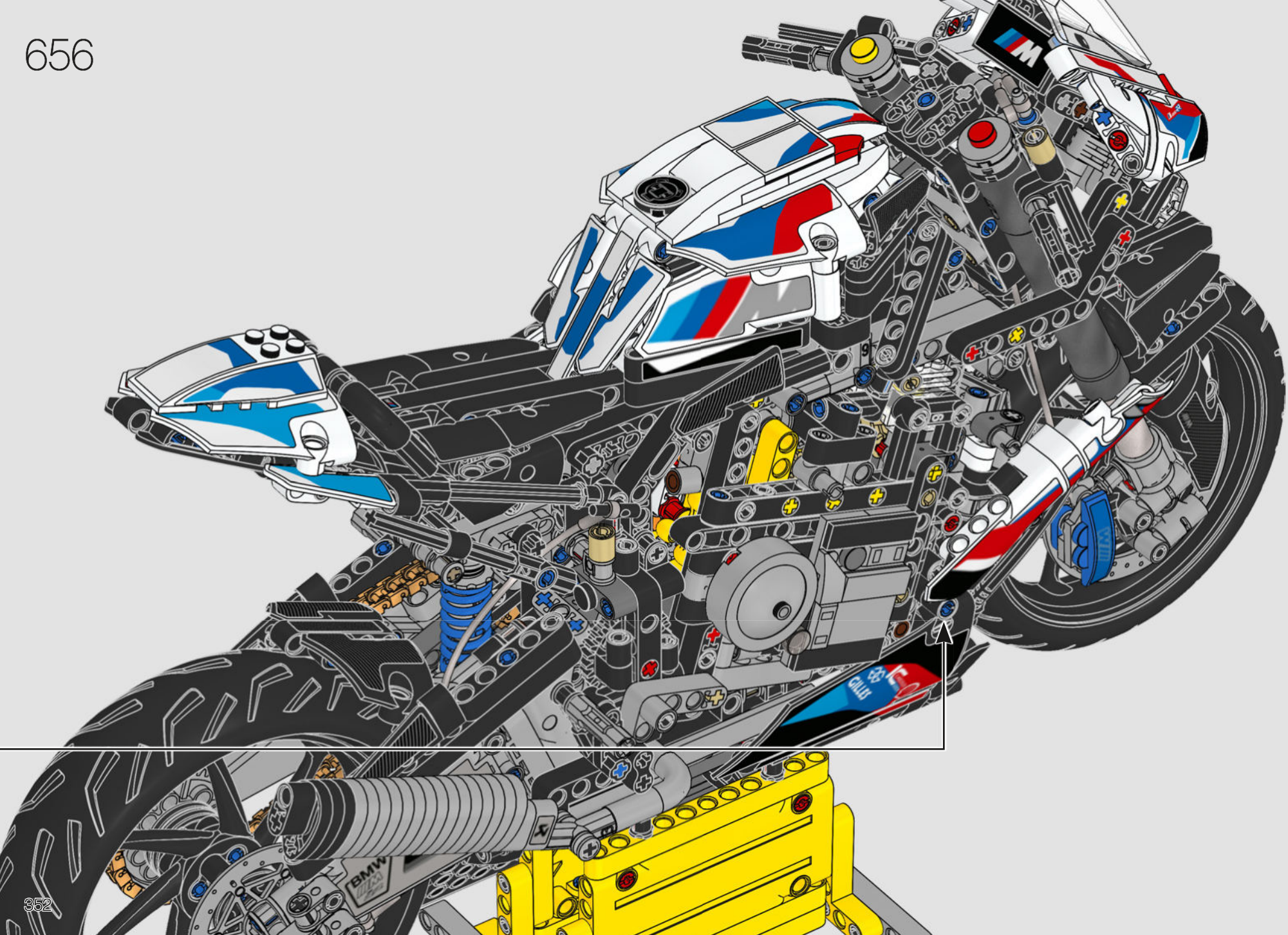

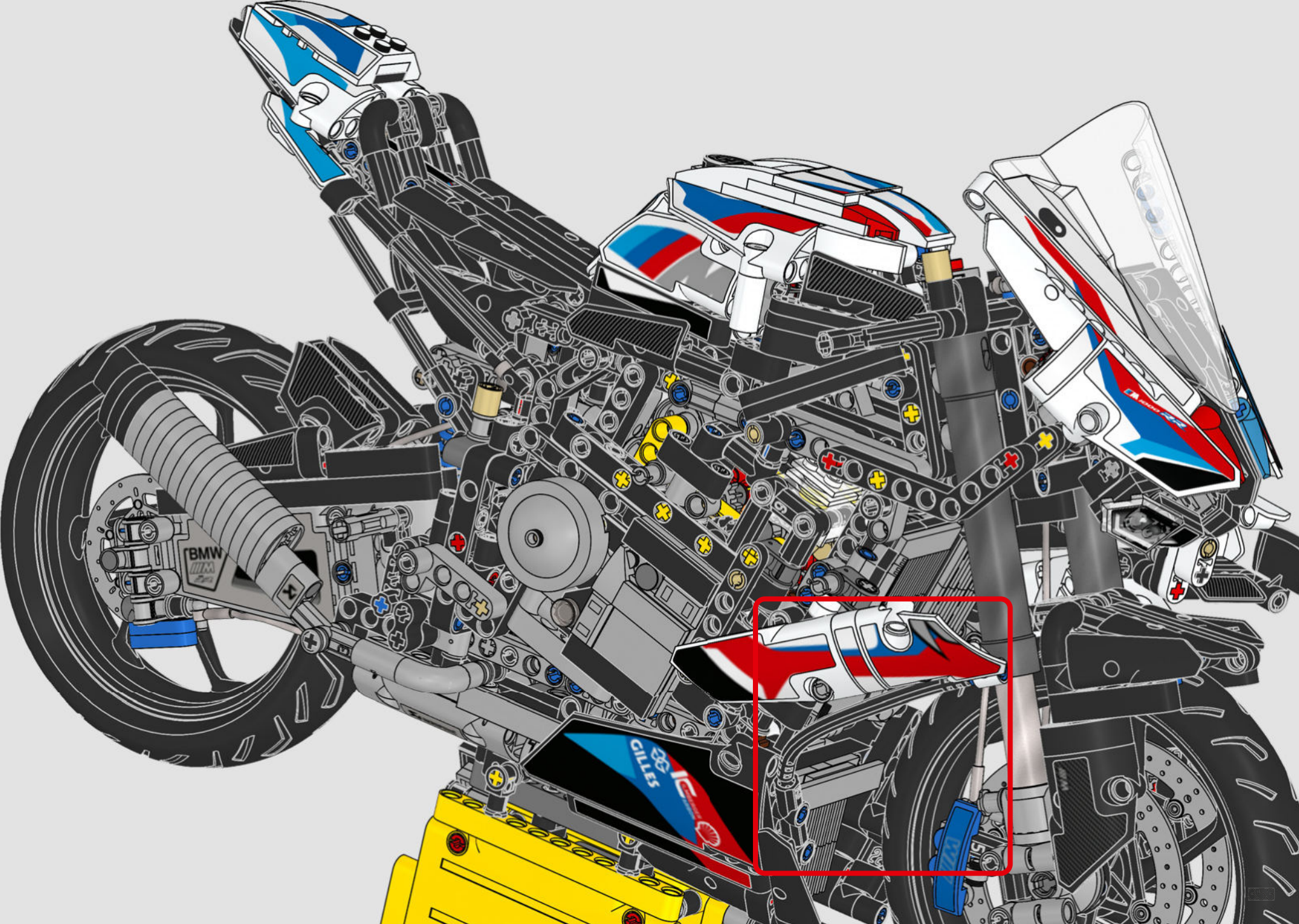

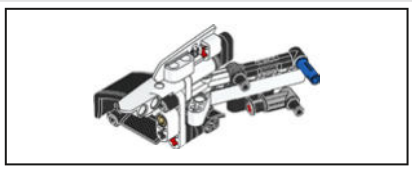

657

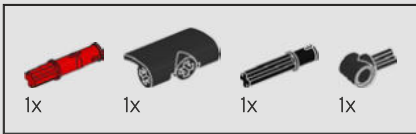
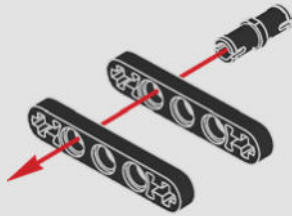

658

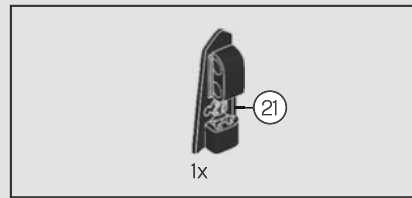
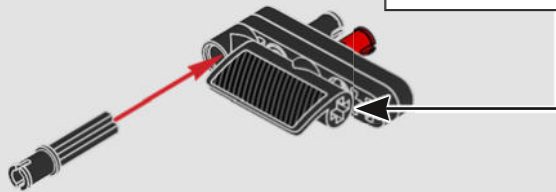
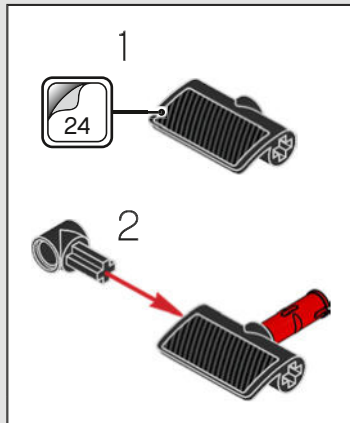

659

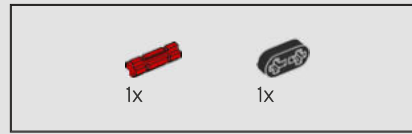
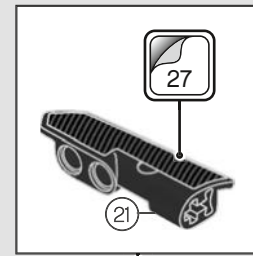

660

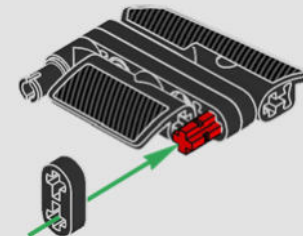

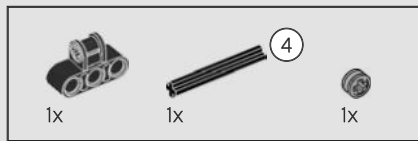

661

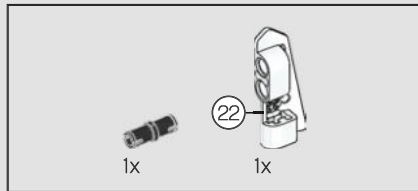
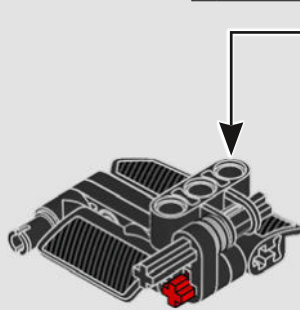
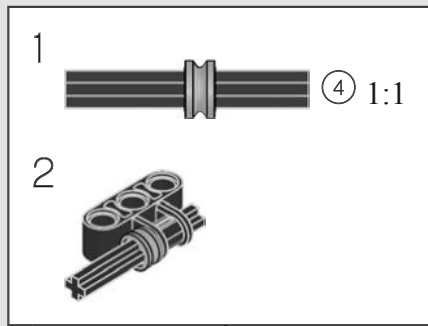

662

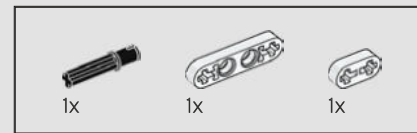
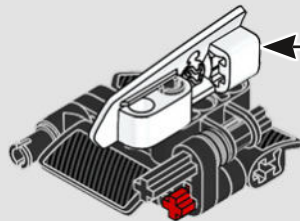
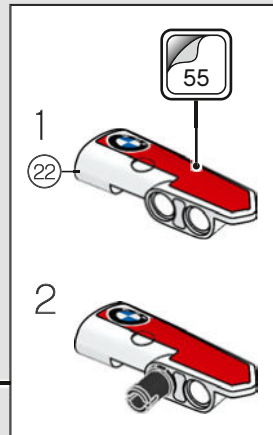

663

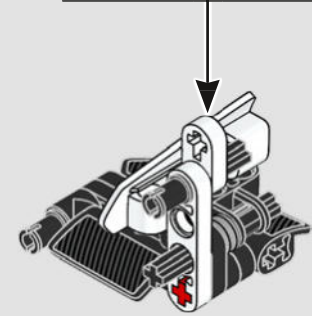
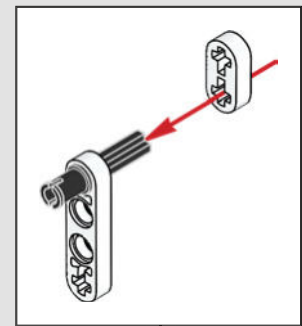

664

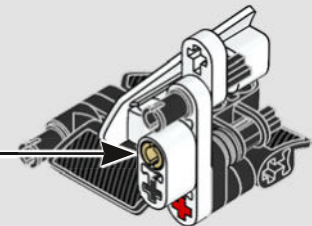
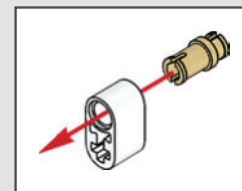

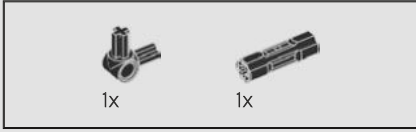
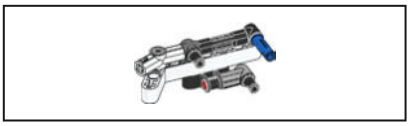

665

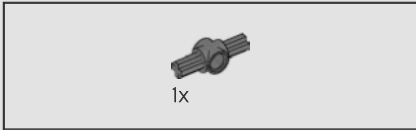

666

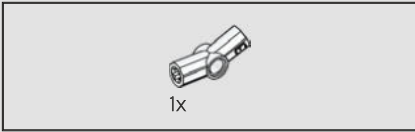
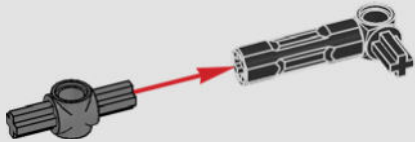

667

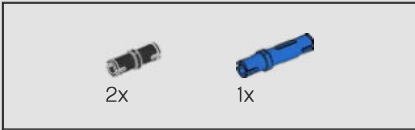

668

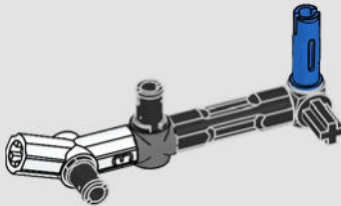

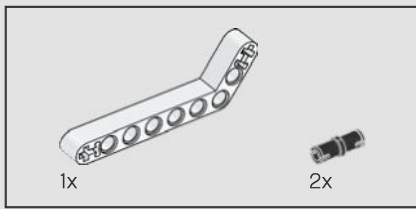

669

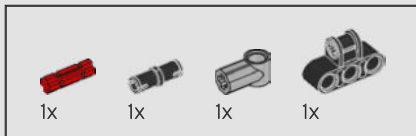
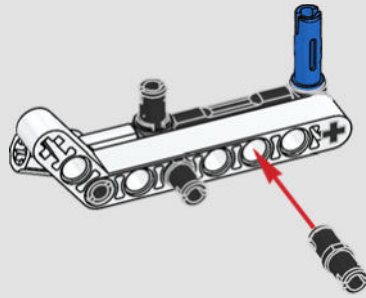

670

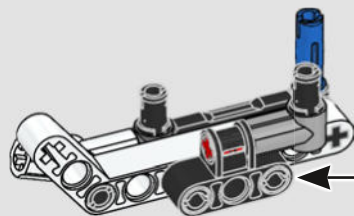
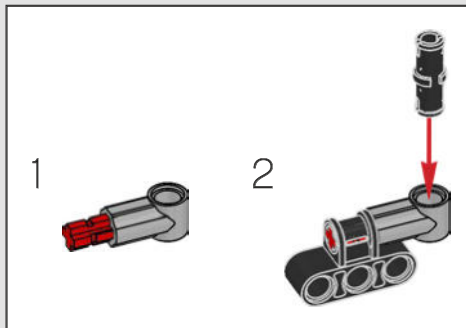

671

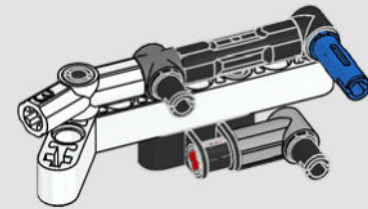

672

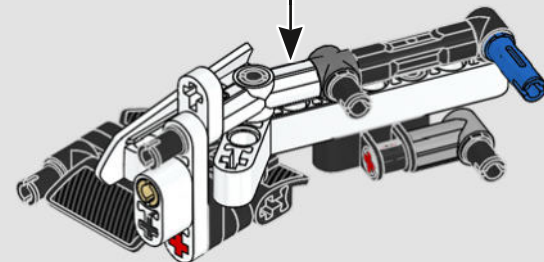



673

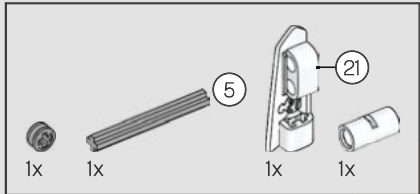
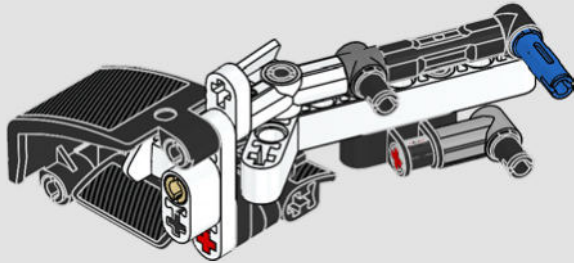
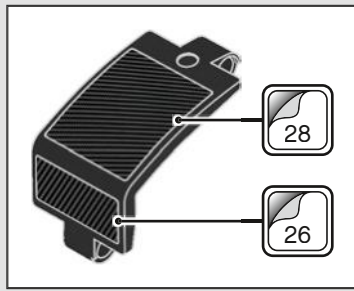

674

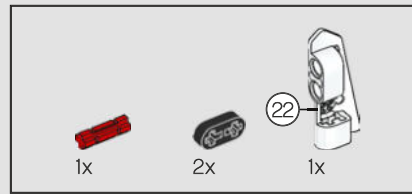
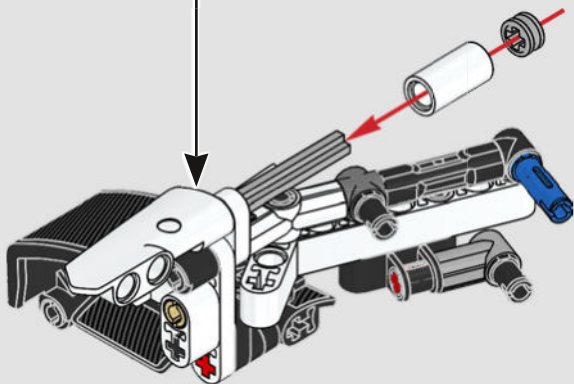
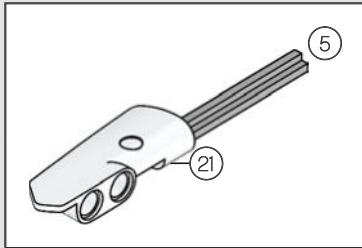

675

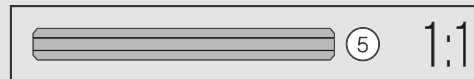
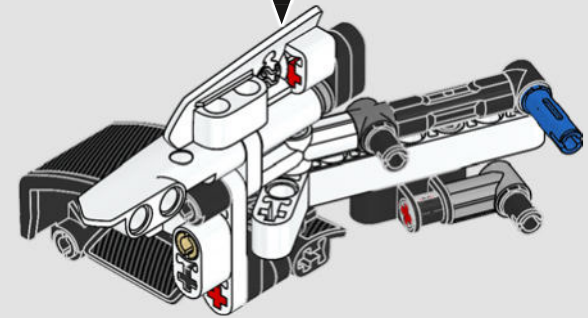
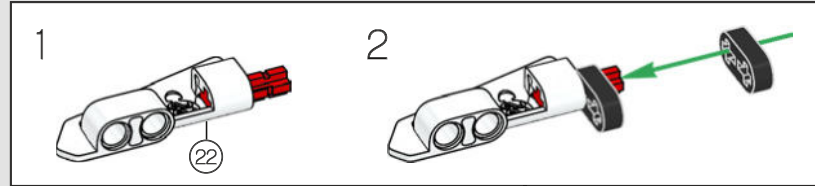

676

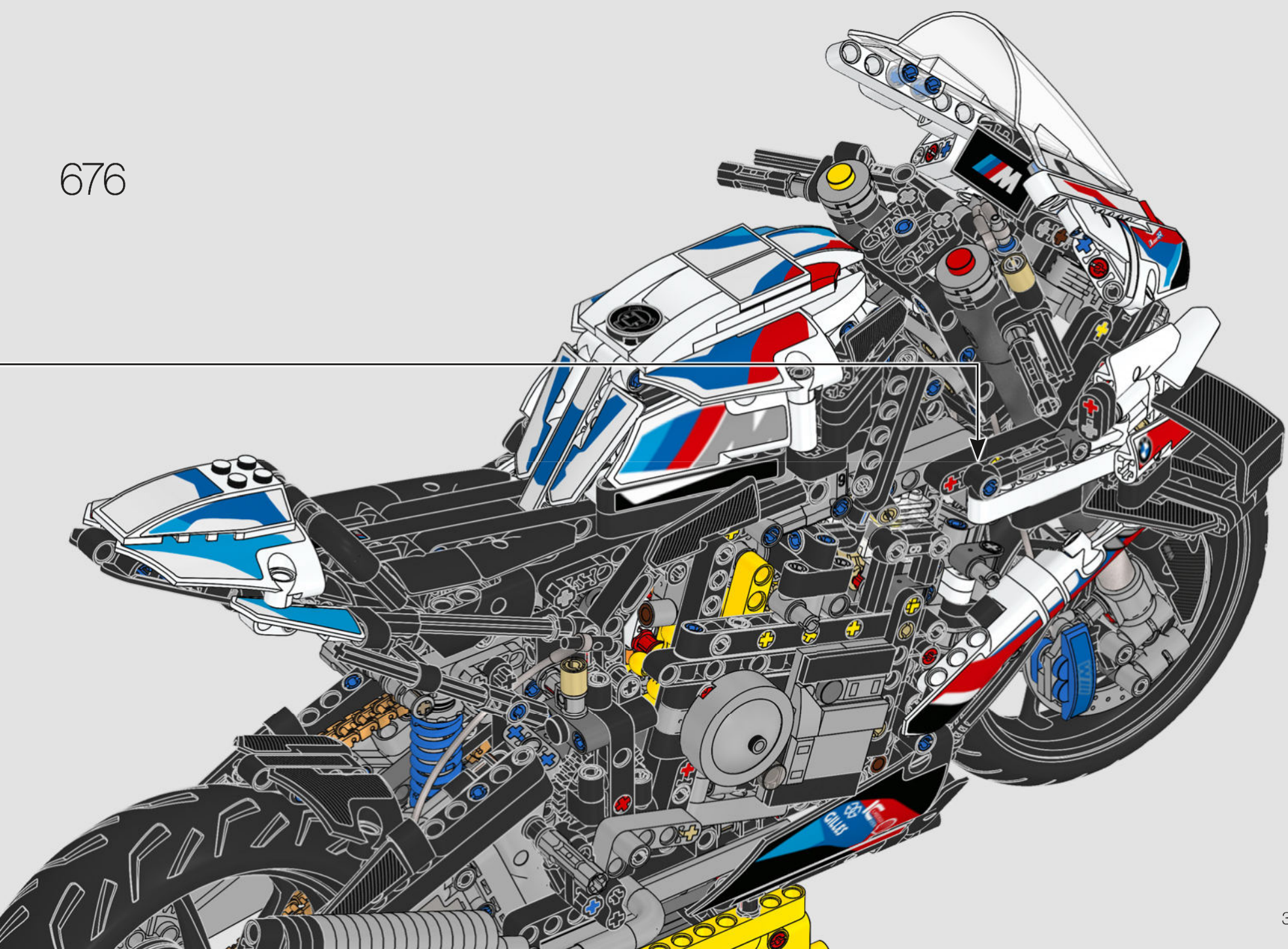

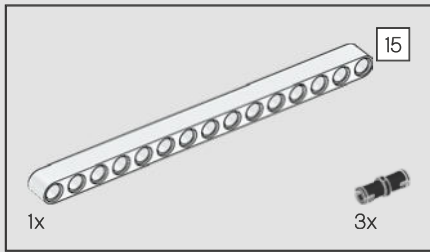
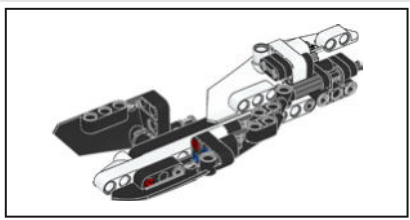

677

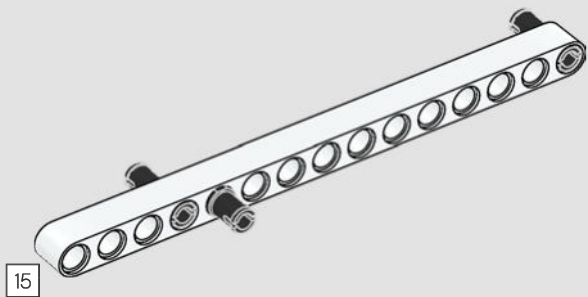

678

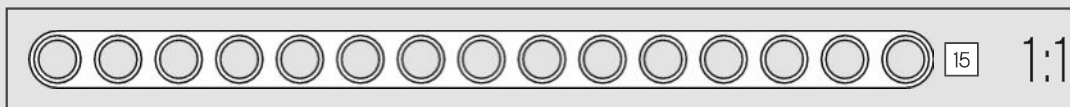
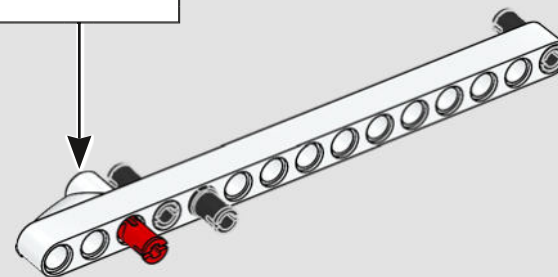
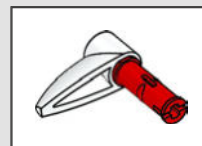

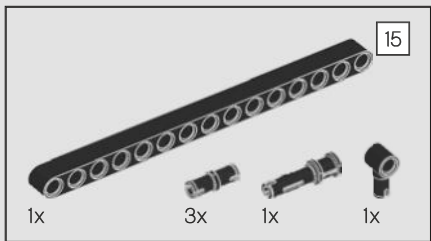

679

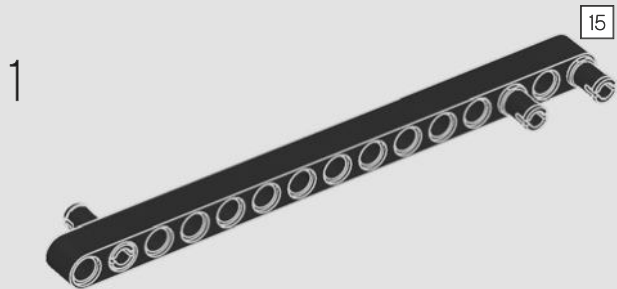

2

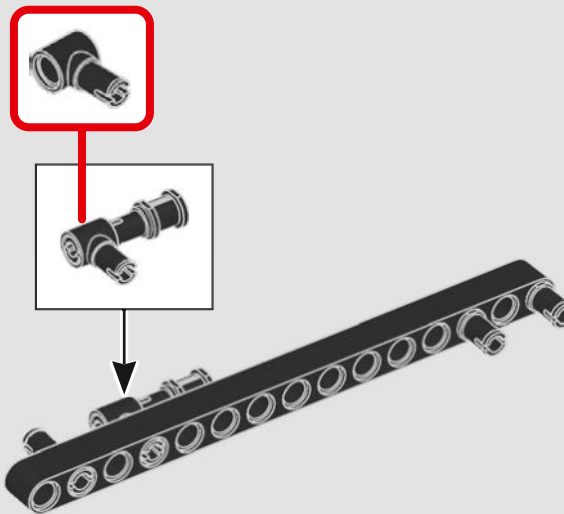

680

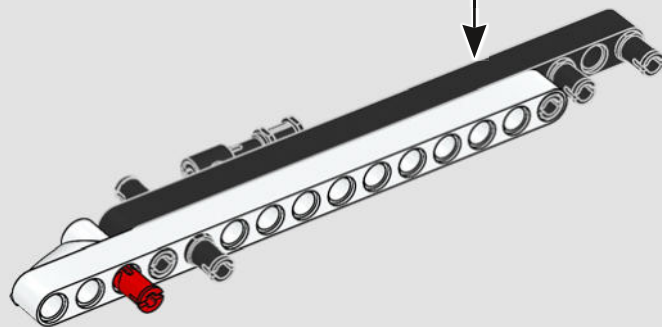

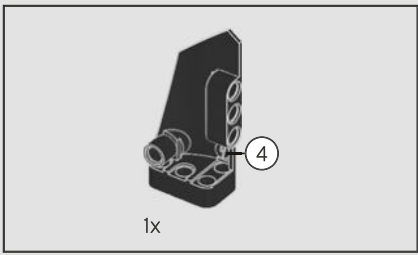

681

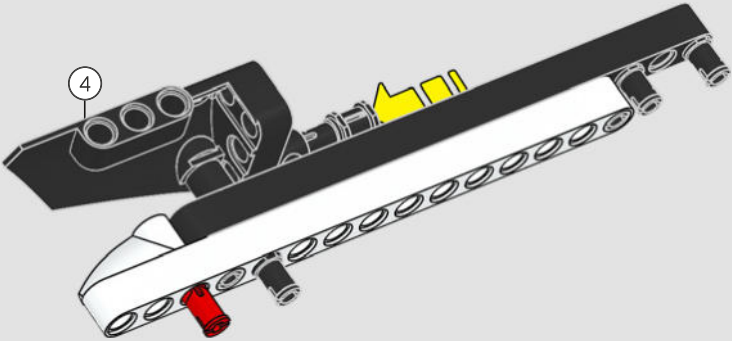

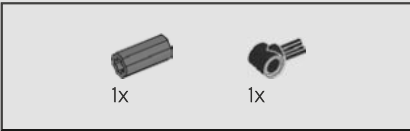
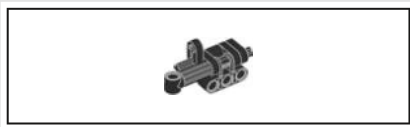

682

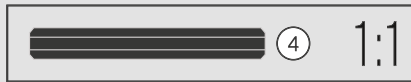
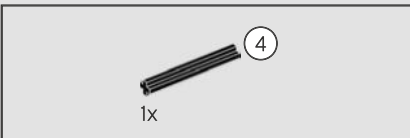
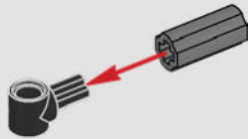

683

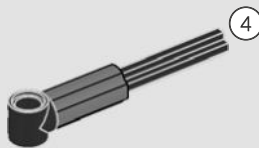

684

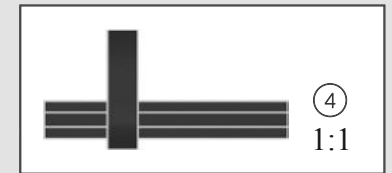
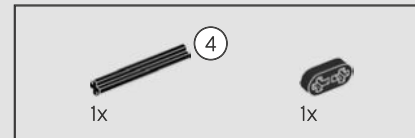
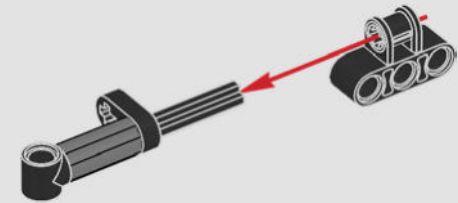

685

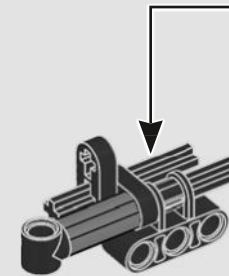



686

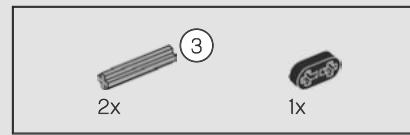
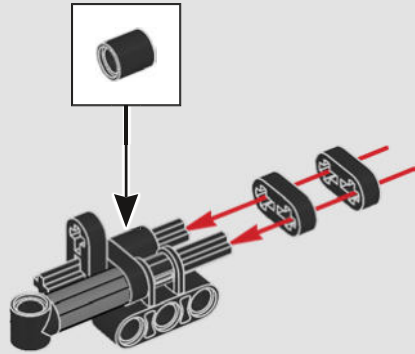

688

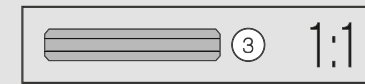
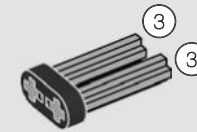

689

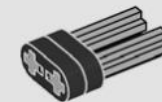

687

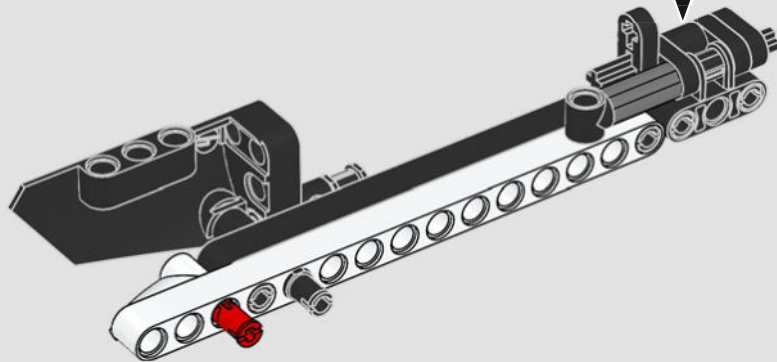

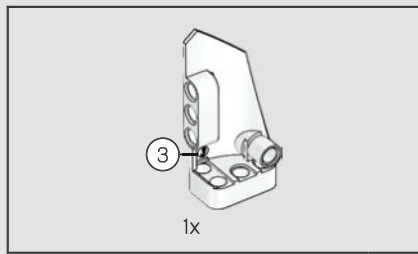

690

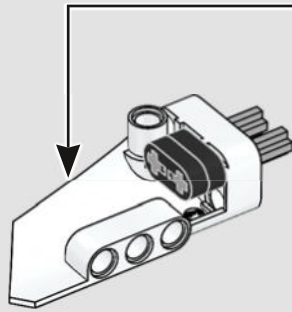
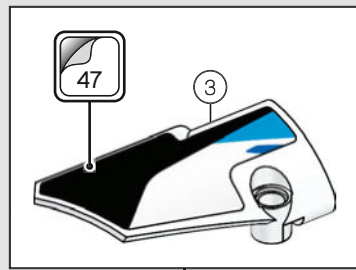

691

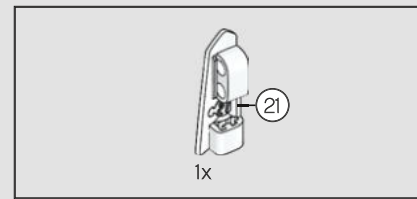
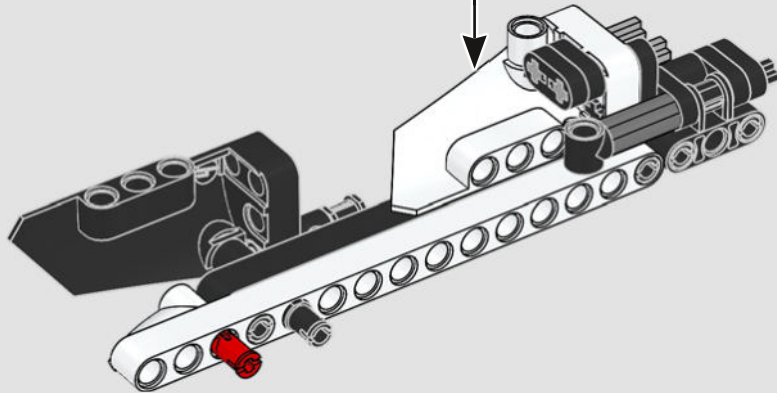

692

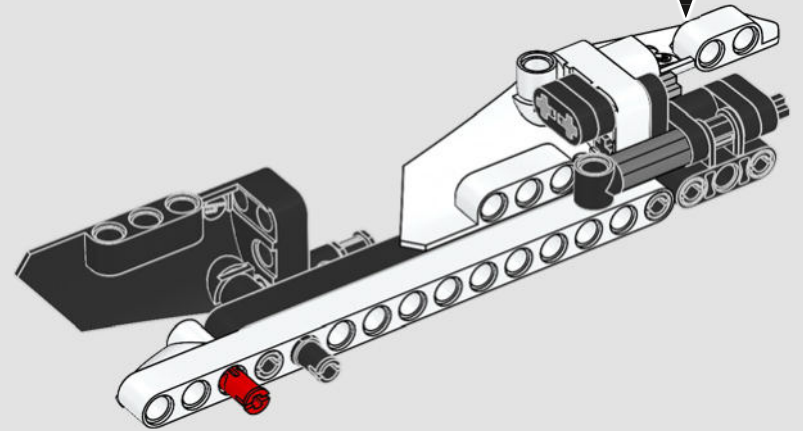
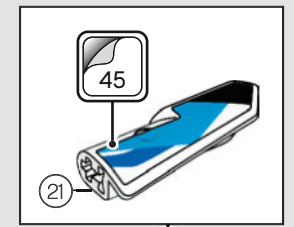

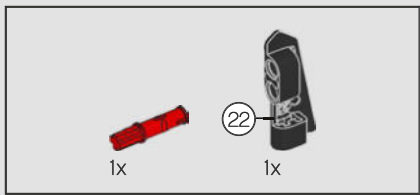

693

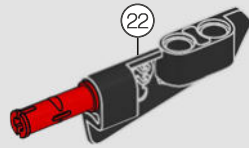

694

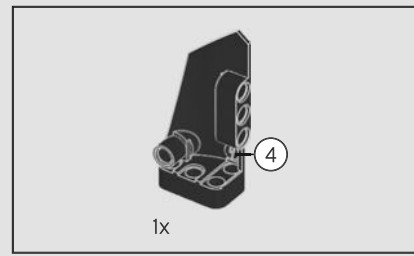
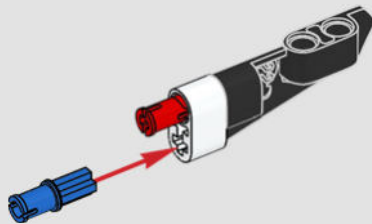

695

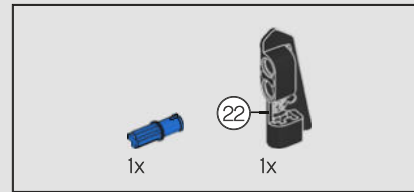
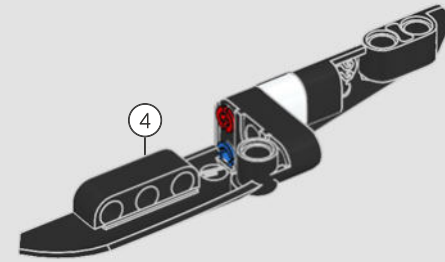

696

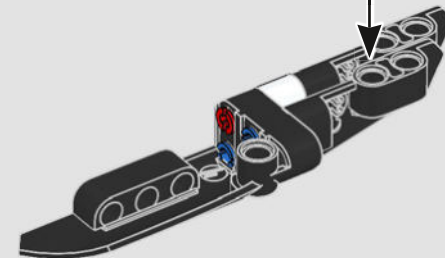
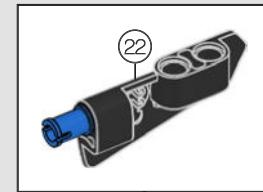

697

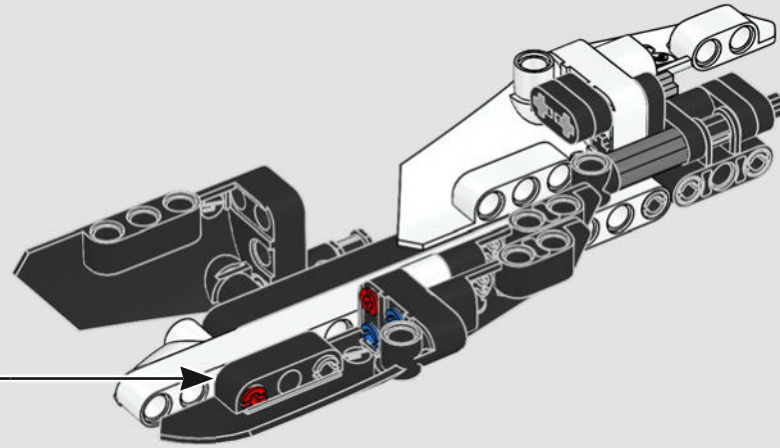

698

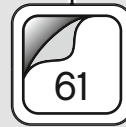
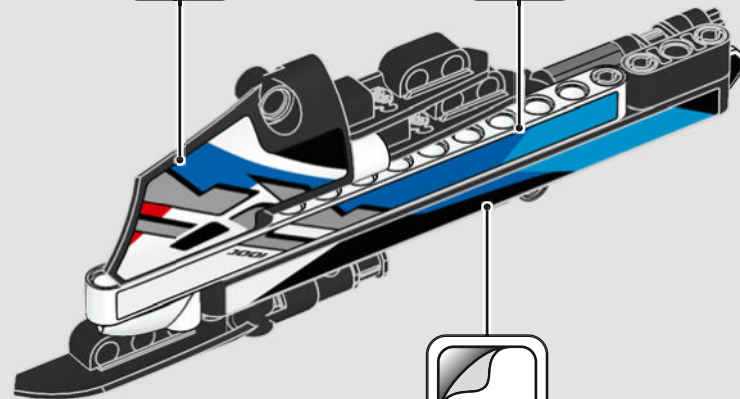

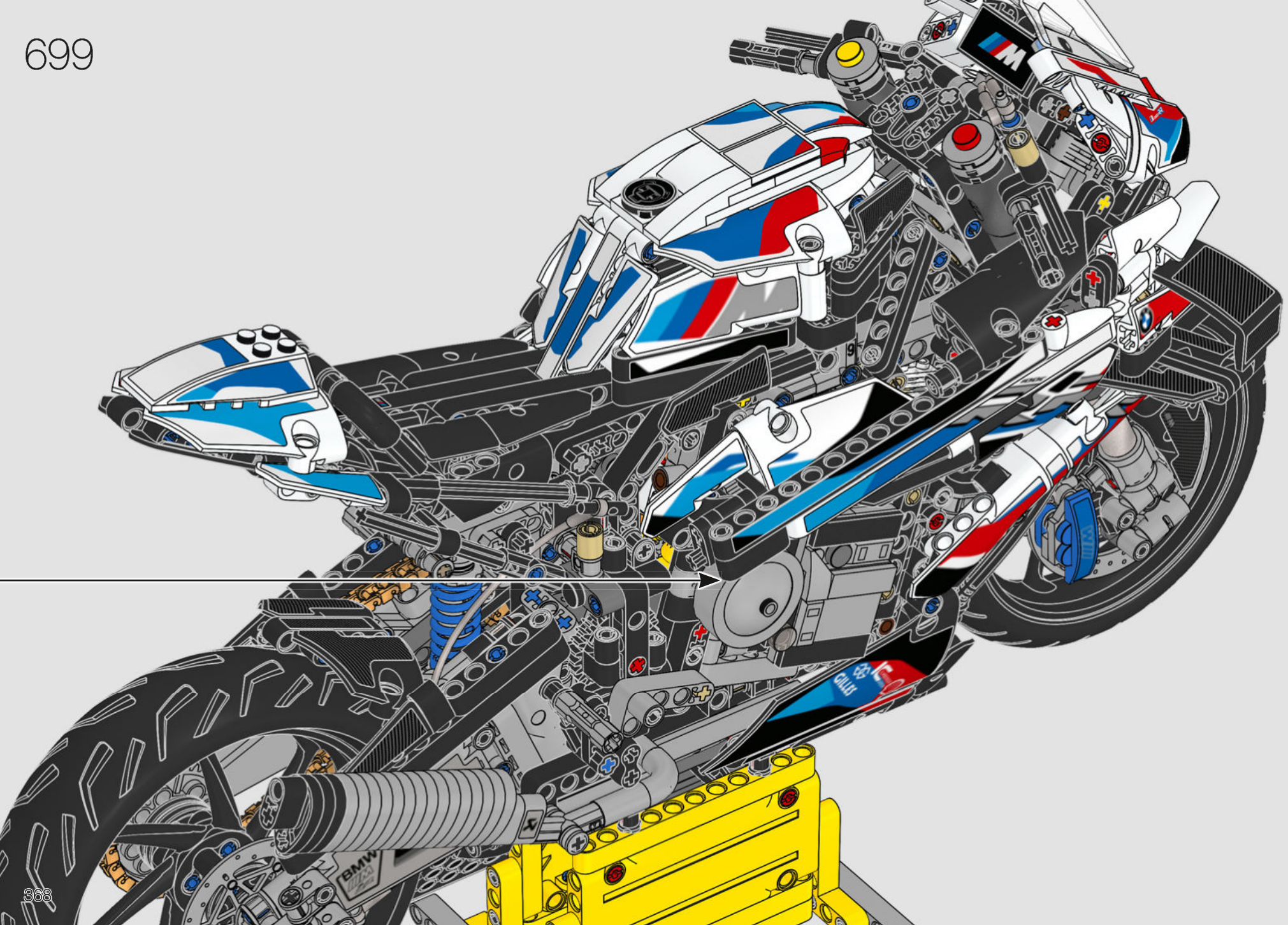

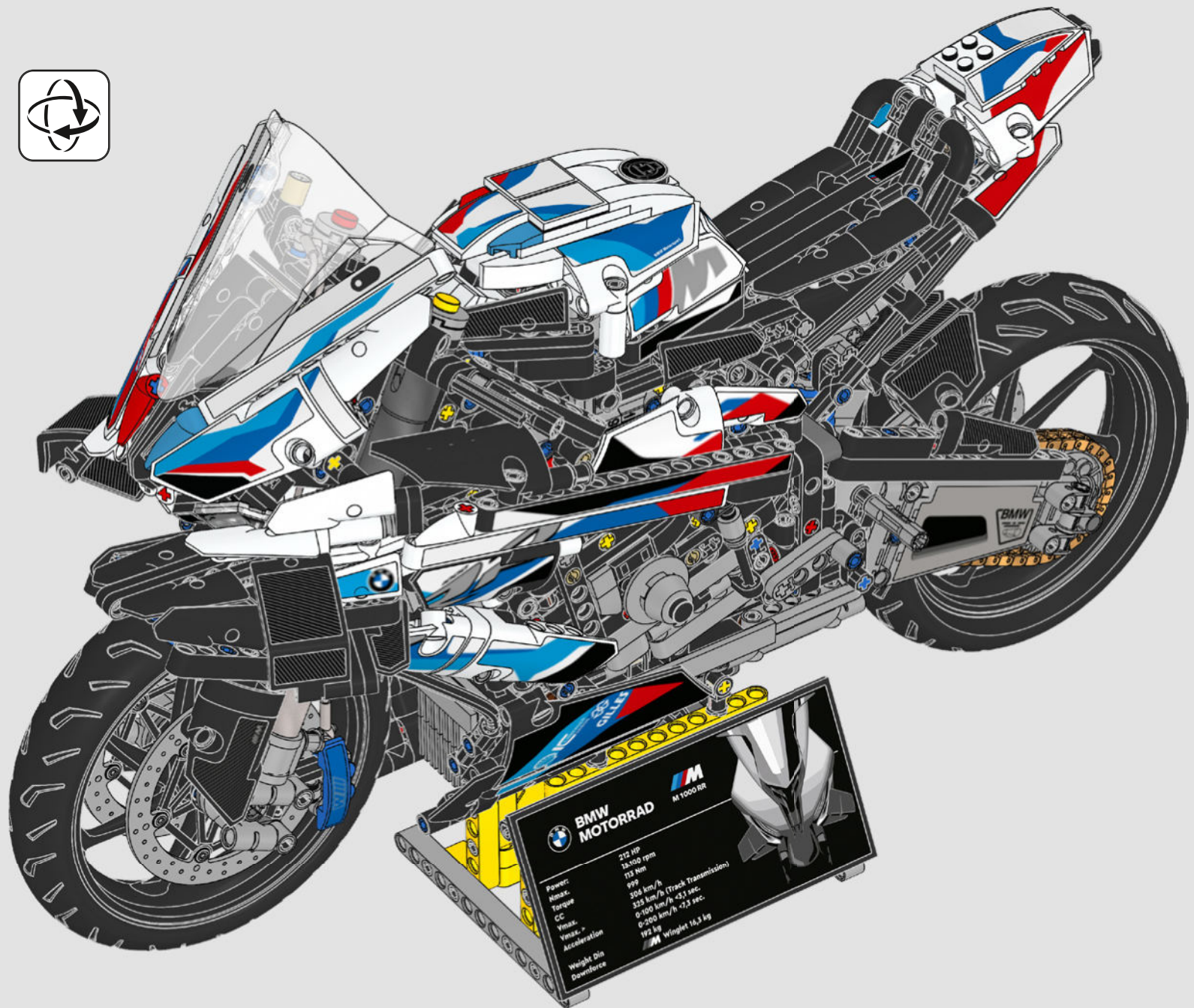

BMW
MOTORRAD

M
M 1000 RR

212 HP
13,500 rpm
113 Nm
199
304 km/h
325 km/h (Track Transmission)
0-100 km/h < 3.1 sec.
0-200 km/h < 7.3 sec.
192 kg
Winglet 16.3 kg

Power: 212 HP
rpm: 13,500 rpm
Torque: 113 Nm
CC: 199
Vmax: 304 km/h
Acceleration: 0-100 km/h < 3.1 sec.
0-200 km/h < 7.3 sec.
Weight: 192 kg
Downforce: Winglet 16.3 kg

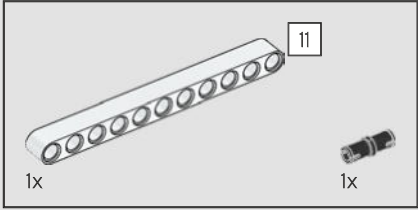
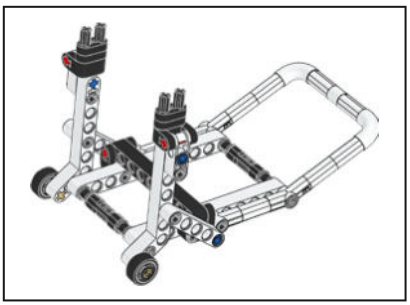

1

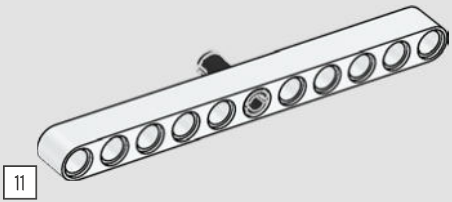

2

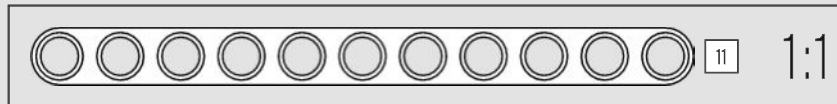
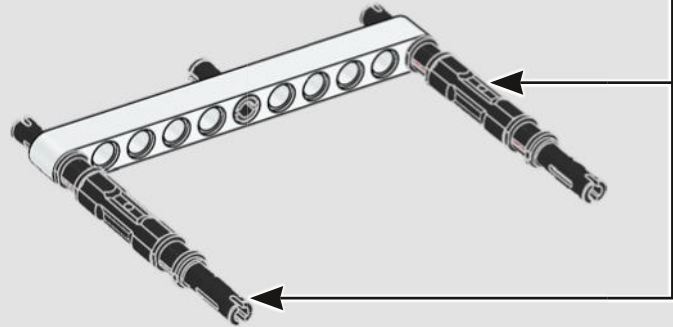
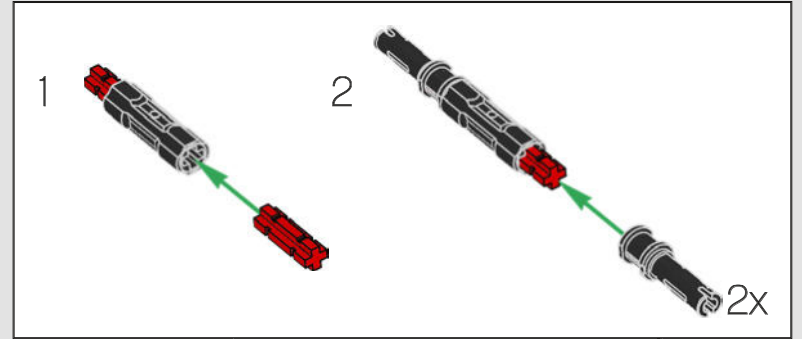

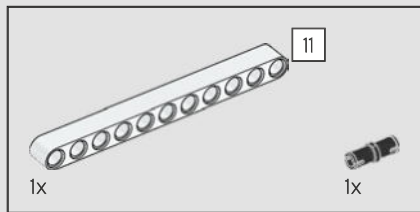

3

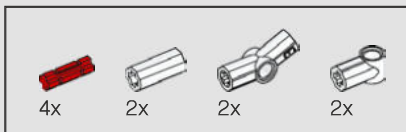
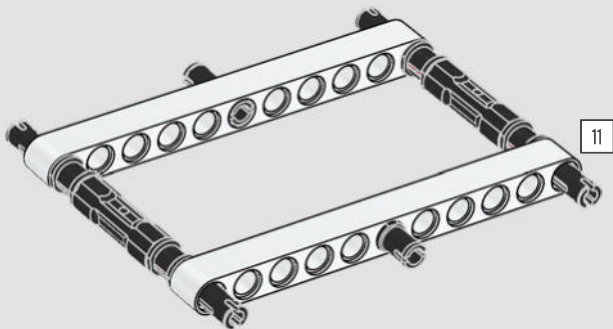

4

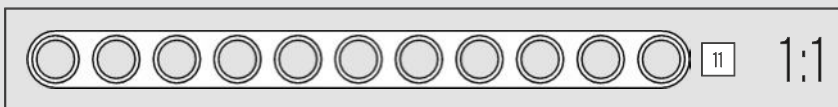
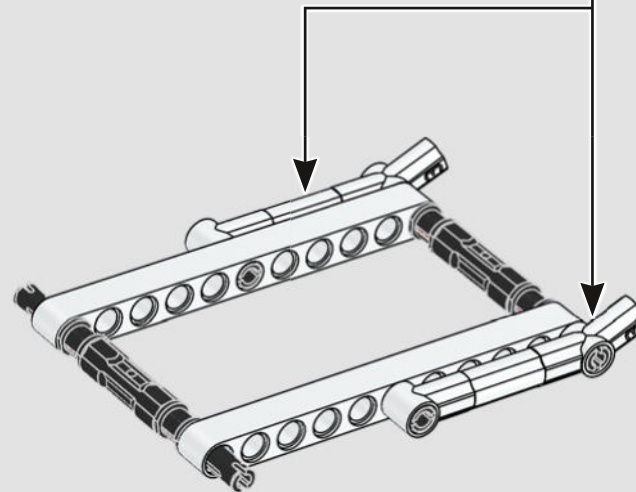
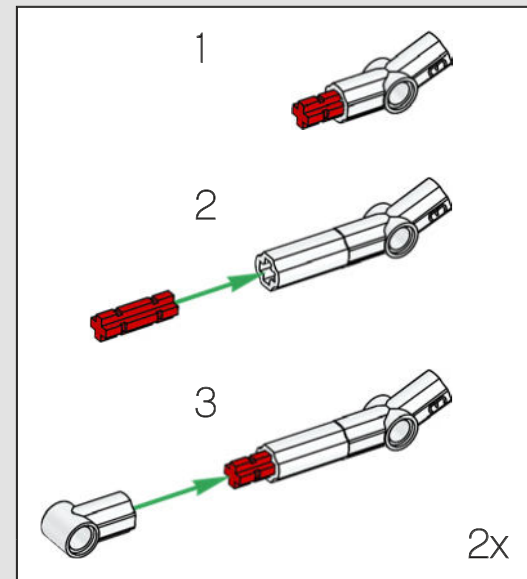



5

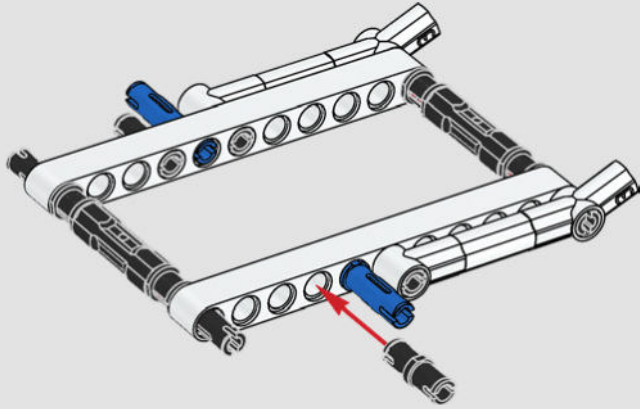

6

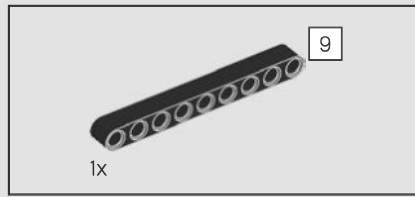
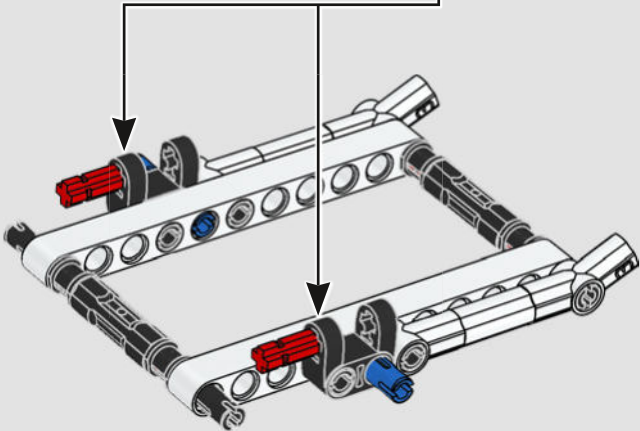
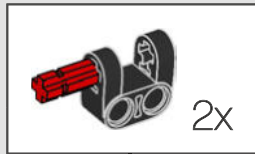

7

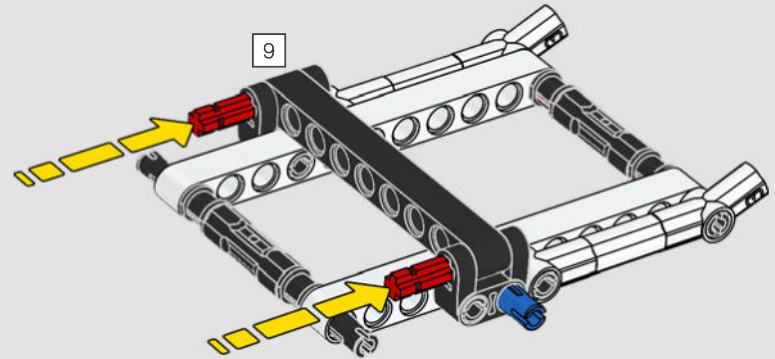

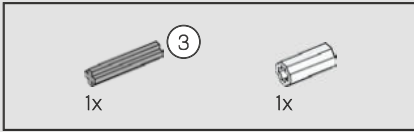
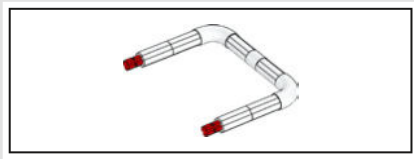

8

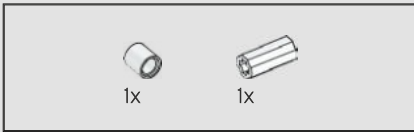
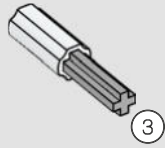

9

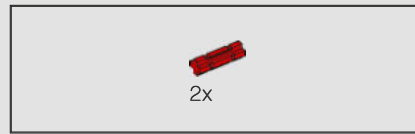
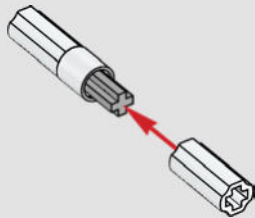

10

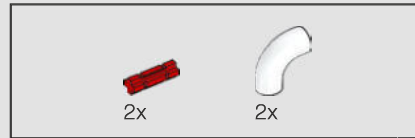
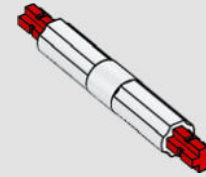

11

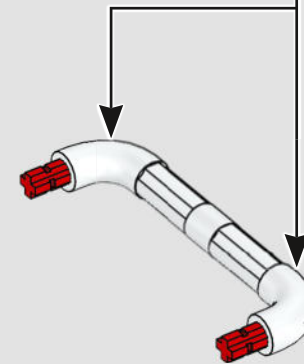
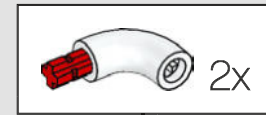

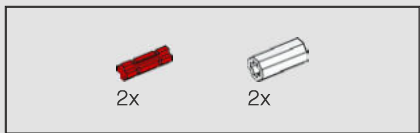

12

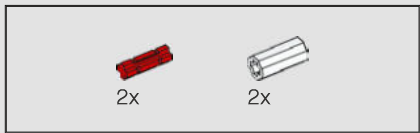
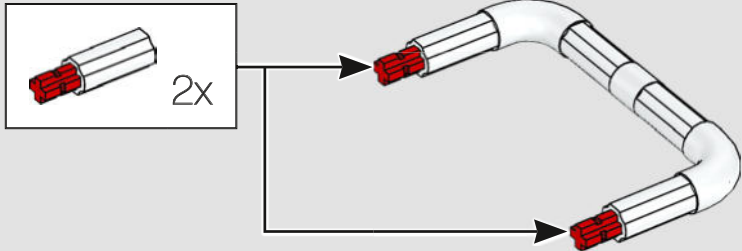

13

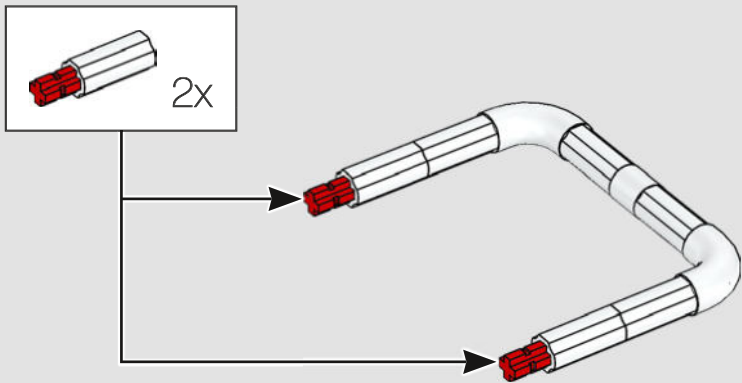

14

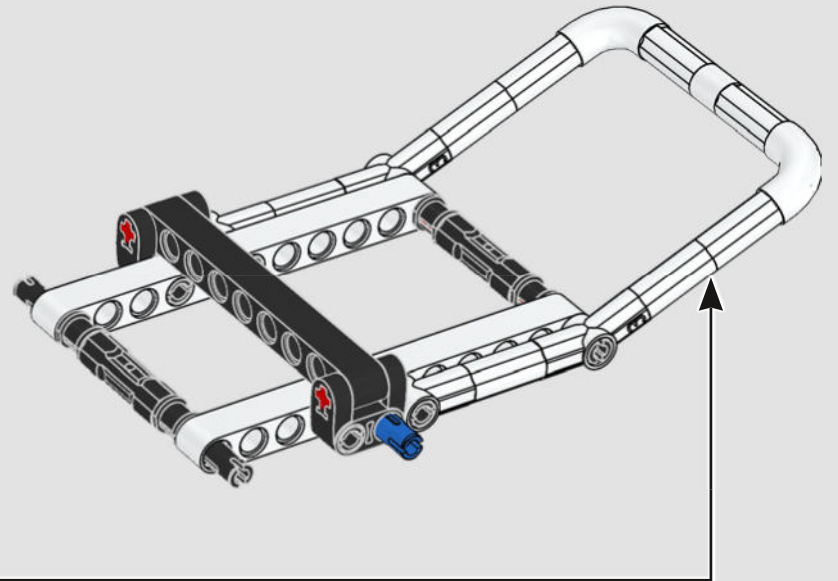

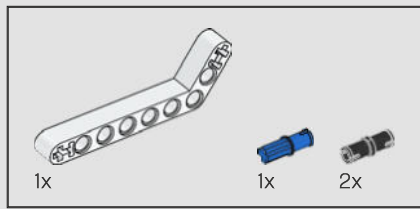

15

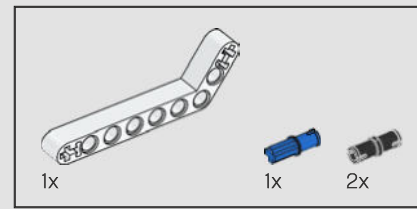
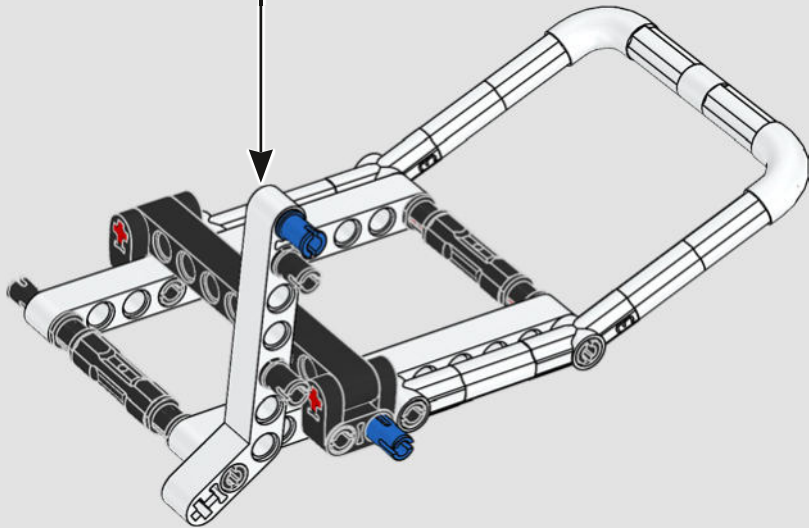
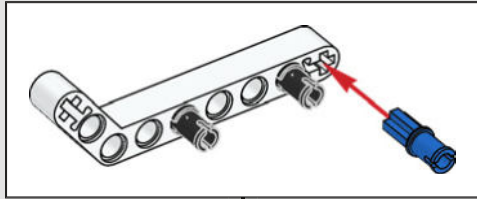

16

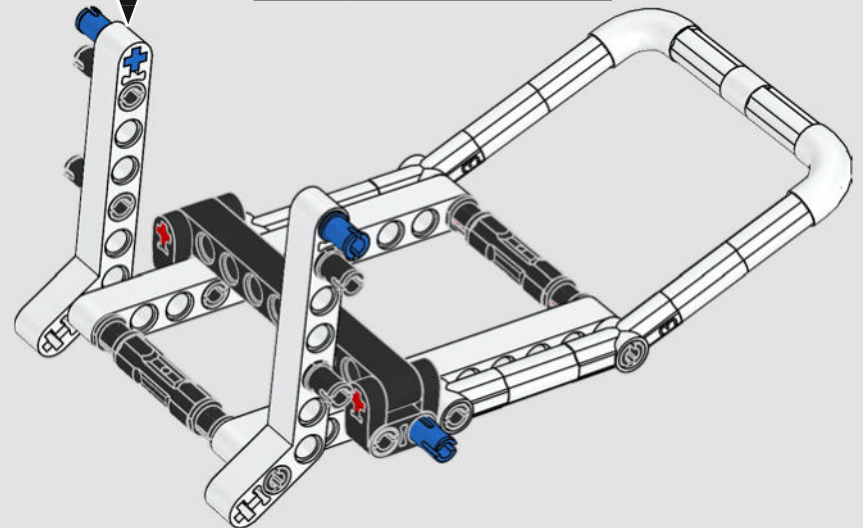
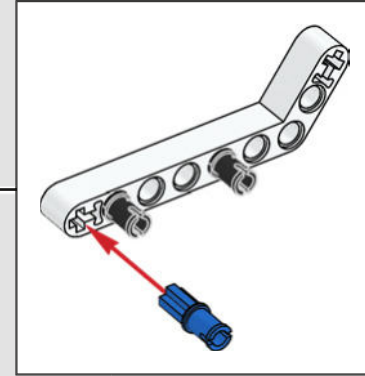

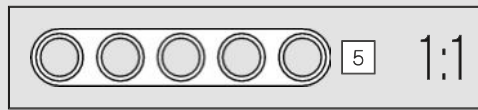
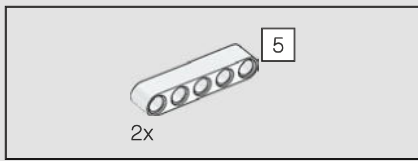

17

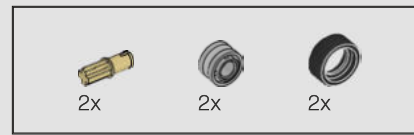
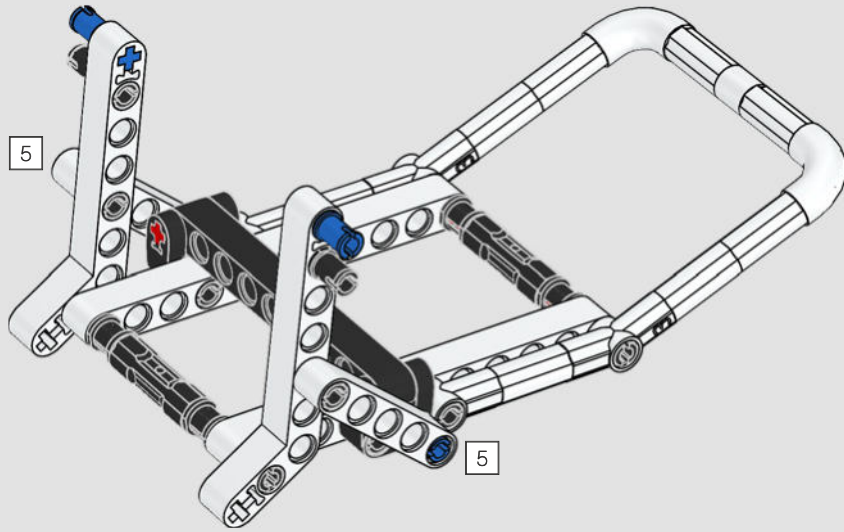

18

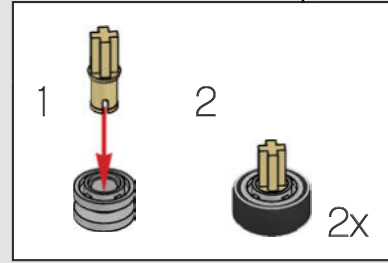
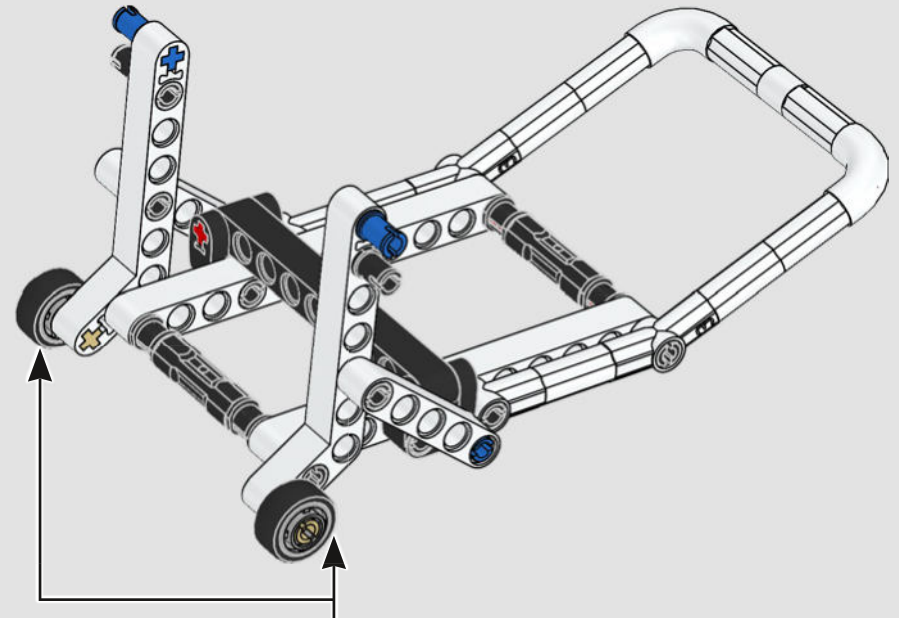



19

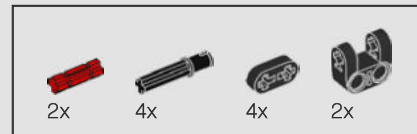
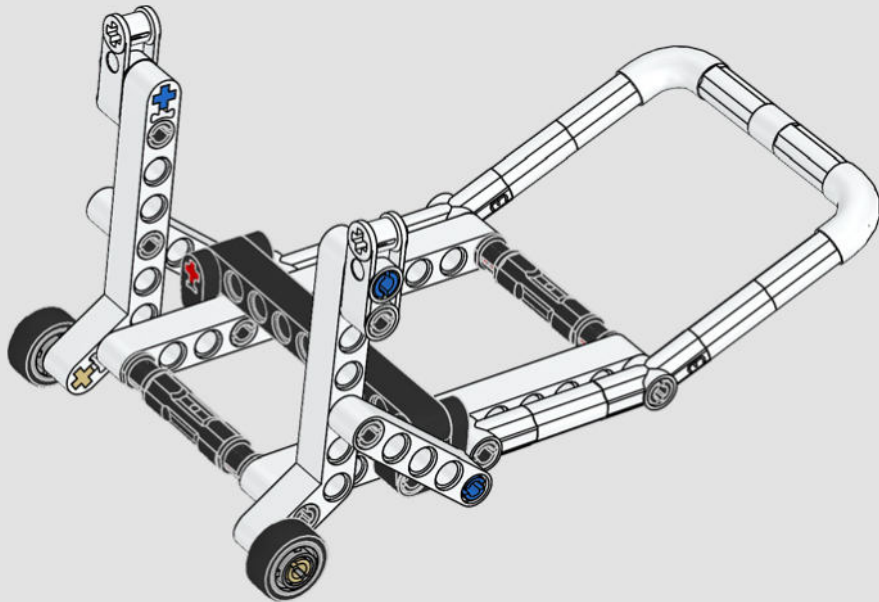

20

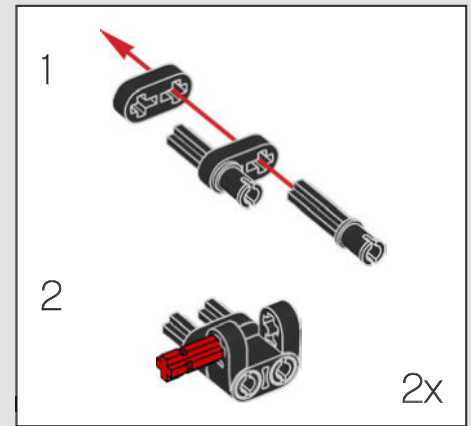
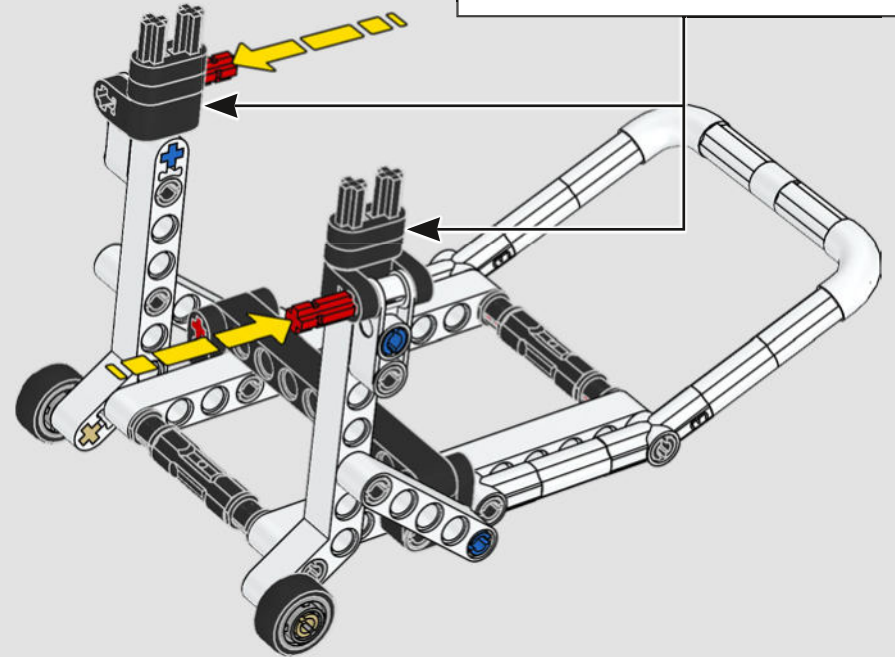

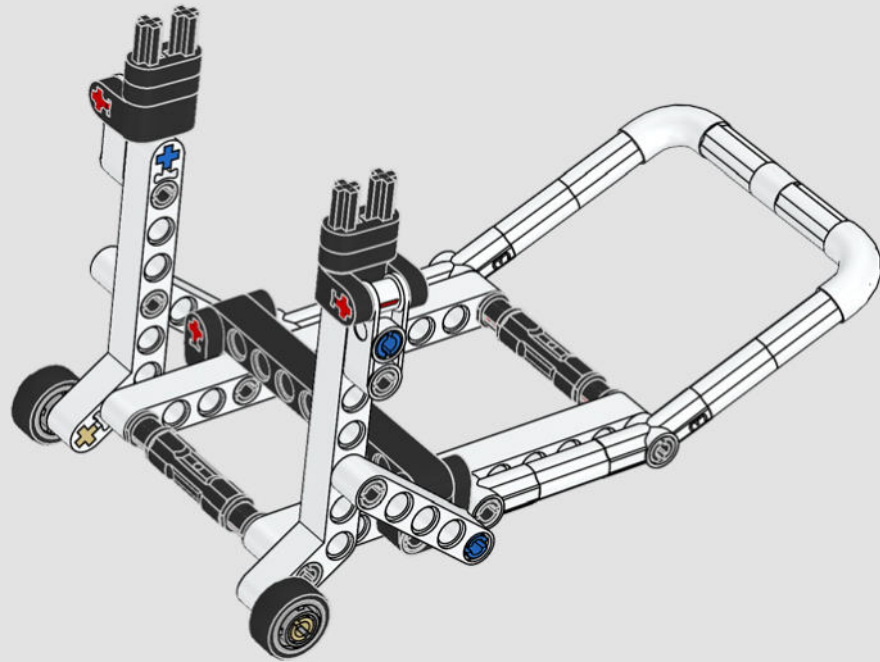

700

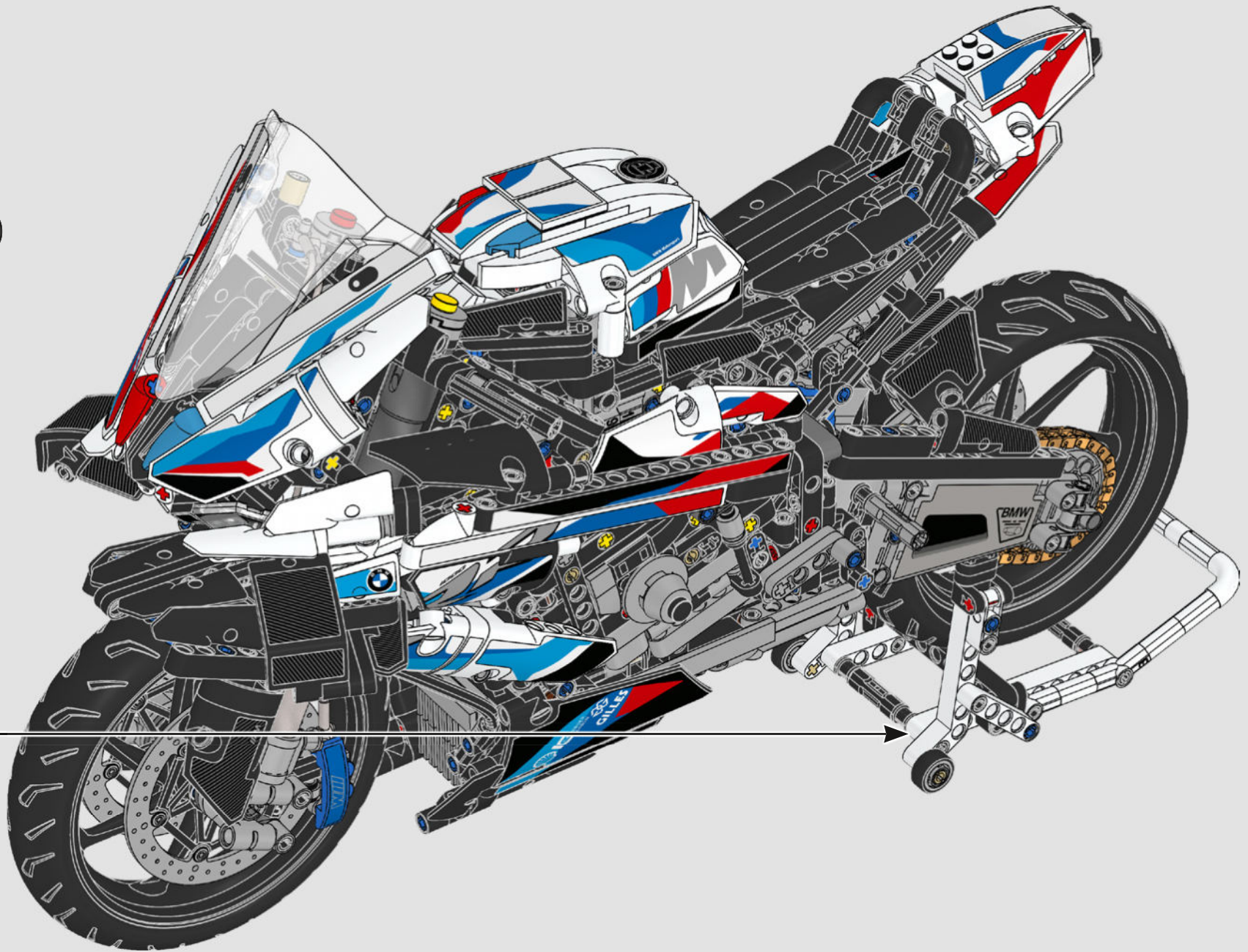

- 1x 6177114
- 2x 6282148
- 2x 4544140
- 7x 6343987
- 10x 6371416
- 2x 6323918
- 7x 6330084
- 2x 6332573
- 2x 6194851
- 2x 6179606
- 7x 6265135
- 4x 6345327
- 8x 6212049
- 2x 3200001
- 6x 6173116
- 3x 6034044
- 2x 6271349
- 2x 6288218
- 2x 6330960
- 1x 6047220
- 4x 6261390
- 2x 6271870
- 2x 4249112
- 1x 362301
- 2x 4249021
- 2x 366601
- 1x 4558874
- 1x 4558878
- 2x 6360072
- 6x 4547582
- 2x 302101
- 1x 6132212
- 2x 6156667
- 6x 4547581
- 2x 6045936
- 2x 302001
- 2x 4249021
- 2x 366601
- 1x 4179869
- 5x 6276842
- 4
- 9
- 11
- 15
- 3
- 5
- 2
- 1

- 1x 303401
- 4x 6001831
- 4x 6028103
- 2x 4542578
- 3x 6167923
- 15x 6013938
- 3x 6355727
- 5x 4666579
- 2x 6346517
- 1x 6321305
- 2x 4666999
- 1x 6284574
- 13x 6271820
- 4x 6360104

- 1x 6177507
- 62x 4142865
- 2x 6167939
- 7x 6100930
- 1x 4179355
- 1x 6285599
- 1x 6273712
- 37x 6209519
- 5x 6347789
- 3x 6273211
- 4x 6129995
- 1x 4142132
- 1x 6130002
- 2x 6130004
- 4x 6284575
- 37x 4143005
- 1x 6177507
- 2x 6130009
- 69x 4206482
- 1x 6224999
- 2x 6344176
- 132x 6299413
- 2x 4649773
- 1x 6284577
- 4x 4112203
- 1x 403224
- 2x 4187122
- 2x 4119474
- 3x 6284189
- 7x 6130008
- 10x 4144022
- 4
- 5
- 6
- 8
- 5

- 2x 6315482
- 69x 4206482
- 1x 6224999
- 2x 6344176
- 132x 6299413
- 2x 4649773
- 1x 6284577
- 4x 4112203
- 1x 403224
- 2x 4187122
- 2x 4119474
- 3x 6284189
- 7x 6130008
- 10x 4144022
- 1x 6130009
- 1x 4495934
- 1x 6130010
- 6x 6028107
- 7x 6130012
- 2x 6311003
- 1x 6170421
- 3x 6284070
- 3x 6168646
- 17x 6121485
- 23x 6282140
- 1x 6181720
- 7
- 7
- 9
- 11
- 11

- 2x 4177431
- 14x 6319983
- 2x 6196548
- 1x 6181713
- 3x 4143187
- 2x 4246901
- 43x 6338428
- 6x 6322045
- 4x 6261371
- 12x 6316923
- 6x 6284699
- 207x 6279875
- 2x 403226
- 4x 6179182
- 1x 6070695
- 16x 6253260
- 8x 6099801
- 34x 6265091
- 10x 6326047
- 8x 4512363
- 4x 6280394
- 6x 6331716
- 10x 6349281
- 4x 6261371
- 12x 6316923
- 6x 6284699
- 207x 6279875
- 2x 403226
- 4x 6179182
- 1x 6070695
- 21
- 21

- 8x 6313520
- 2x 6262897
- 10x 6271810
- 4x 6323668
- 3x 6273708
- 2x 242026
- 2x 4124096
- 25x 6089119
- 27x 6321745
- 4x 4107765
- 4x 6261386
- 1x 6276951
- 3x 4552347
- 2x 4142822

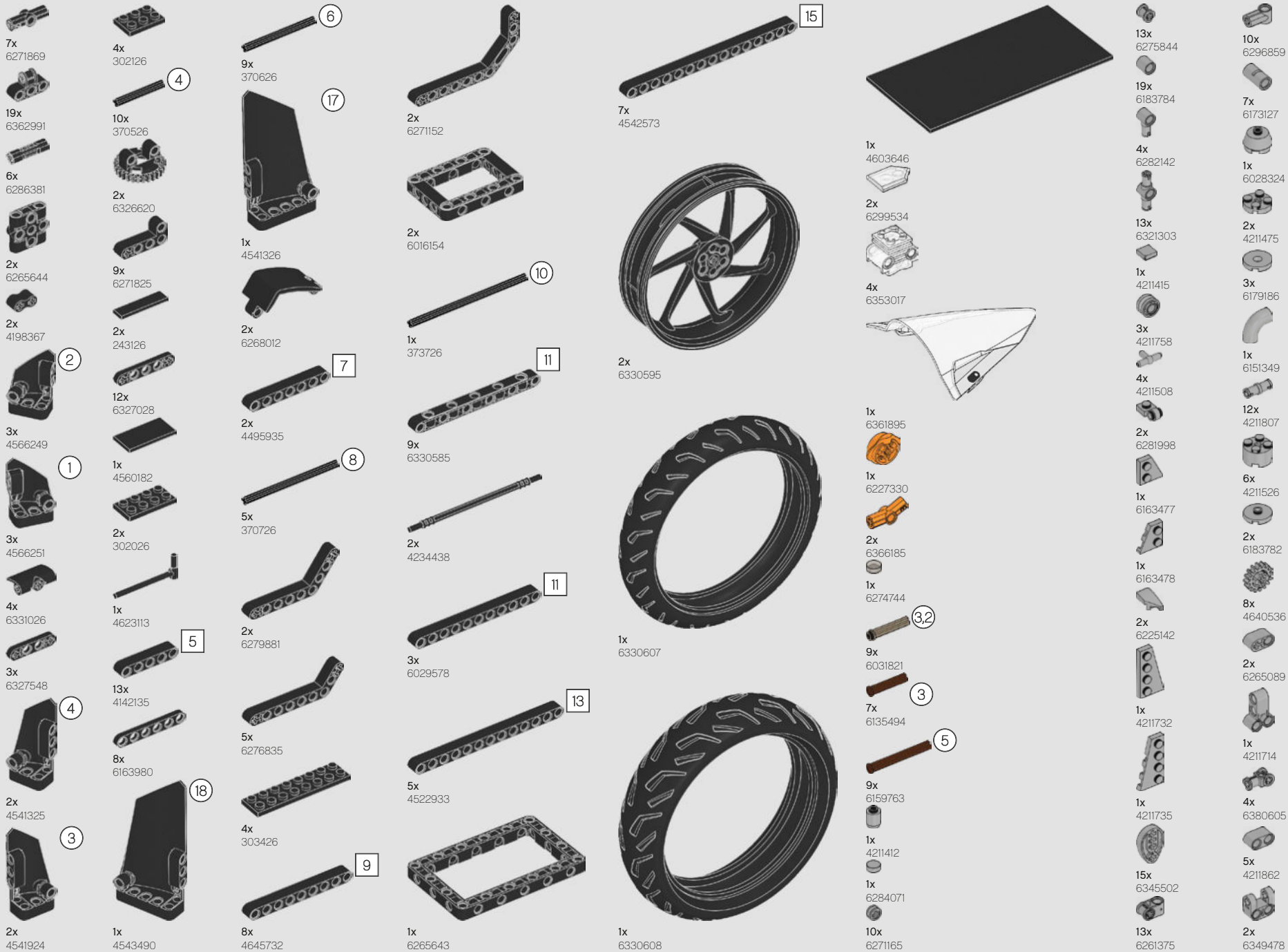



2x
6280396



4x
6268924



6x
6168633



2x
6134378



2x
4211469



30x
4211350



4x
6000018



1x
4667578



2x
6331859



4x
6360043



2x
6262905



7x
6273724



4x
6279023



4x
4211397



1x
4490127



33x
4211815



1x
4211536



1x
6261387



2x
4652235



13x
6276969



3x
6331441



2x
6282158



1x
6070564



1x
4211429



1x
6211969



1x
4558169



2x
6302648



2x
6317177



1x
6013547



1x
6011808



2x
6273212



2x
6370947



1x
4211396



1x
6171894



1x
6271831



2x
4211356



2x
4211445



1x
6303438



4x
6328063



4x
6331428



3x
4503416



7x
4211639



1x
6195314



2x
4211651



6x
4211713



1x
6285654



10x
6170293



1x
6278129



1x
4211549



6x
4211805



2x
4211452



9x
4495930



2x
6257136

5



2x
6331551

9



1x
6102449

13



2x
4522934

2x



62x
6327007

62x



62x
6348019

2x



2x
6116017

7



3x
6210590

7



3x
6210590

7



3x
6210590

7



3x
6210590

7



3x
6210590

7



3x
6210590

7



3x
6210590

7



3x
6210590

7



3x
6210590



2x
4211481



2x
6331551



1x
6102449

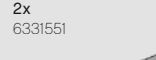

2x
4522934



62x
6327007

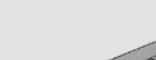

62x
6348019



2x
6116017

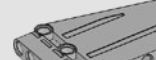

3x
6210590

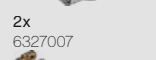

3x
6210590

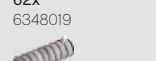

3x
6210590

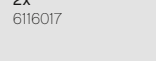

3x
6210590



3x
6210590

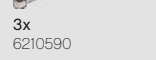

3x
6210590



3x
6210590



2x
6328490



1x
6211418



1x
6292486



1x
6364922



1x
6284596



4x
4210759



8x
6261374



2x
6100931



3x
6135014



2x
4516546



2x
6364452



6x
6167281



1x
6133119



1x
6133119



1x
6133119



1x
6133119



11x
4210751



1x
6317653



2x
4610378



3x
6271814



7x
6083620



3x
4499858



3x
6321715



3x
6321715



2x
4645730



1x
4603472



1x
4603472



1x
4603472



1x
4603472



1x
4603472



1x
4603472



1x
4603472



Customer Service

Kundenservice

Service Consommateurs

Servicio Al Consumidor

LEGO.com/service or dial



00800 5346 5555 :



1-800-422-5346 :





FEEDBACK AND WIN



FEEDBACK AND WIN

Your feedback will help shape the future development of this product series.

Please visit:

FEEDBACK UND GEWINNEN

Dein Feedback trägt zur Weiterentwicklung dieser Produktreihe bei.

Geh auf:

COMMENTEZ ET GAGNEZ

Vos commentaires nous aideront à concevoir les futurs produits de cette gamme.

Rendez-vous sur :

COMENTA Y GANA

Tu opinión nos ayudará a dar forma al desarrollo de esta serie de productos en el futuro.

Visita:

反馈有奖

您的反馈将有助于我们在今后改进本系列产品。

请访问：

[LEGO.com/productfeedback](https://www.lego.com/productfeedback)

By completing, you will automatically enter a drawing to win a LEGO® set.

Terms & Conditions apply.

Durch Ausfüllen nimmst du automatisch an der Verlosung eines LEGO® Preises teil.

Es gelten die Teilnahmebedingungen.

En envoyant vos commentaires, vous serez automatiquement inscrit(e) à un tirage au sort qui vous permettra de remporter un prix LEGO®.

Offre soumise à conditions.

Al contestar, participarás automáticamente en el sorteo y podrás ganar un set LEGO®.

Sujeto a Términos y Condiciones.

完成我们的反馈调查，即可自动进入抽奖环节，赢取乐高®套装。

适用《条款和条件》。

LEGO and the LEGO logo are trademarks of the LEGO Group. ©2022 The LEGO Group.

The BMW logo, the BMW Motorrad word mark and the BMW Motorrad model designation are trademarks of BMW AG and are used under license.



M 1000 RR